



IPD-SM82-EZ-II-WX PRODUCT SPECIFICATIONS

System Type	8", coaxial, surface-mount, ported, Dante™ IP controlled
Frequency Response (± 3 dB) ¹	Sealed: 60 Hz - 20 kHz
Frequency Response (± 10 dB) ¹	Sealed: 40 Hz - 20 kHz
Max. SPL @ 1 M ²	101 dB
Coverage Angle (± 6 dB @ 2 kHz)	70° horizontal 90° vertical
Coverage Angle (± 6 dB @ 10 kHz)	110° horizontal 100° vertical
Coverage Angle (Avg. 2-10 kHz)	90° horizontal 105° vertical
Aiming Angle	0°-90°
Directivity Factor (Q)	5.2 (averaged 100 Hz - 10 kHz); 12 (2 kHz)
Directivity Index (DI)	6.2 (averaged 100 Hz - 10 kHz); 10.8 (2 kHz)
Transducer: Low-Frequency Driver	203 mm (8") polypropylene woofer with butyl rubber surround
Transducer: High-Frequency Driver	25.4 mm (1") soft dome tweeter
Low-Frequency Voice Coil	38.1 mm (1.5") high temperature Kapton
Crossover Frequency	2.5 kHz
Network Type: Low Pass	12 dB per octave, 2nd order
Network Type: High Pass	12 dB per octave, 2nd order
Enclosure Material	High impact polystyrene (HIPS)
Grille	Aluminum with powder-coat finish
Inputs	RJ45 Ethernet port
Height	457.2 mm 18"
Width	292.1 mm 11.5"
Depth	251 mm 9.88"
Weight	6.3 kg 13.9 lbs
Included Accessories	Safety cable, wall-mount bracket, port plug, Allen wrench, and water-tight strain-relief bushing
Optional Accessories	N/A
Packaging	One per box
IP-Rating	IP65
Certifications	CE, RoHS, IP 65 (Sealed Version), UL 60065 Listed

Description

The IPD-SM82-EZ-II-WX is an 8", two-way surface-mount speakers for IP-addressable audio networks on the Dante platform. It incorporates an 8" polypropylene woofer and 1" soft dome tweeter in an injection-molded enclosure. The speaker delivers a frequency response of 38 Hz - 20 kHz (± 10 dB) with consistent, broad high-frequency dispersion supplied through SoundTube's proprietary BroadBeam Ring™ technology.

Power, audio, and control are delivered to the speaker via a CAT5 or CAT6 cable; connection on the other end is made to the STNet Switch, which provides 40 W PoE (Power over Ethernet) to each speaker. Configuration of the speaker is done via software. Should any problems occur with the speaker during operation, it will be reported immediately via SoundTube monitoring software.

Features

- STNet IP-addressable, self-powered (PoE) speaker.
- Dante™ I/O for interconnectivity with Dante-enabled audio systems.
- BroadBeam Ring™ delivers a consistent dispersion pattern up to 10 kHz for maximum coverage area per speaker.
- One 8" (203 mm) polypropylene woofer and one 1" (25.4 mm) soft dome tweeter.
- Fast connection of power, audio, and control functions via one CAT5 or CAT6 cable.
- 40 W PoE provided by SoundTube STNet Switch; also works with standard PoE+ and PoE switches.
- Provides report-back on any problems via SoundTube software.
- Aluminum grille with powder-coat finish.
- Vertical and horizontal mounting offer precision aiming for indoor and outdoor applications.
- UL60065 listed.
- High-quality black or white paint finish.
- Included accessories: safety cable, wall-mount bracket, port plug, Allen wrench, and watertight strain-relief bushing.

¹ Frequency response measured in half or full space as dictated by speaker mounting configuration

² Max output based on max continuous power

Applications

Engineered for cost-conscious applications requiring true intelligibility, quality low-frequency response and quick installation, the versatile IPD-SM82-EZ-II-WX delivers smooth and even coverage ideal for casinos, convention centers, gyms, nightclubs, aerobic rooms, airports, transportation hubs, shipping centers, and stadiums.

Patented Technologies

SoundTube Entertainment and the MSE Audio Group constantly develop new technologies which enhance audio product performance. SoundTube Entertainment innovations are protected by multiple U.S. and international patents, which explicitly cover SoundTube dome, enclosure and dispersion technologies. The MSE Audio Group actively defends its patents in order to protect SoundTube resellers and end-users.

Technical Data and Specification Tools

SoundTube Entertainment strives to provide complete and effective technical information and data to dealers, engineers and designers. All data is available from SoundTube Entertainment or at www.soundtube.com.

Technical data and downloads include:

- EASE™ data - 3-D polar plots.
- EASE™ Address - 2-D modeling for distributed systems
- AutoDesk® Revit® software
- Tech Sheets - technical information and architectural specs for system engineers
- SoundTubeSPEC™ - Proprietary speaker placement software

Independent Data Acquisition and Verification

All data for SoundTube speakers is independently collected from and verified by NWAALabs (www.nwaalabs.com) using their proprietary MACH testing system. All data is collected and analyzed according to ASTM, ISO and AES standards using EASERA, TEF and MLSSA. Full balloon data including both phase and magnitude is compiled into a variety of formats including EASE 4.x, GLL and CLF.

Architectural Specifications

The loudspeaker shall consist of a 203.2 mm (8") low-frequency transducer and a 25.4 mm (1") high-frequency transducer with a frequency dividing network installed in a vented enclosure. The low-frequency voice coil diameter shall be 25.4 mm (1"). The high-frequency transducer shall be constructed of silk material with a proprietary BroadBeam Ring™ waveguide.

Performance specifications of a typical production unit shall be as follows: Usable frequency response shall extend from 38 Hz - 20 kHz (± 10 dB, half space, independently verified). The frequency dividing network shall a crossover frequency of 3.5 kHz. The unit shall accept 40 W PoE in addition to PoE+ and standard PoE, as well as the audio signal from a provided network switch, and shall be configurable via software. Maximum continuous output at 1 M with a 40 W input shall be 101 dB.

Installation and safety attachment for the speaker shall be by U-bracket affixed to the speaker chassis with steel insert. For safety redundancy, a

secondary cable shall be included and attached to the speaker chassis.

The external wiring input connector shall be via RJ45 Ethernet cable. The system shall be for indoor/outdoor applications and shall include a weather-resistant cover over all wire connections.

The enclosure shall be constructed of injection-molded, High Impact Polystyrene (HIPS). The grille shall be constructed of powder-coated aluminum for lasting performance. Overall cabinet dimensions shall be no more than 292.8 mm (11.49") in height by 457.2 mm (18") in width by 254 mm (10") in depth (without SM bracket). The unit shall include port plug, allen wrench, and watertight strain-relief bushing.

The system shall be the SoundTube IPD-SM82-EZ-II-WX for audio over IP Dante™ applications.

SoundTube®

13720 W. 109th St.
Lenexa, KS 66215
Phone: 913.663.5600
Fax: 913.663.3200
Toll Free: 855.663.5600
www.mseaudio.com

All SoundTube speakers come with a 5-year limited warranty and 3-year warranty on all electronics.

Mechanical Drawings

Top

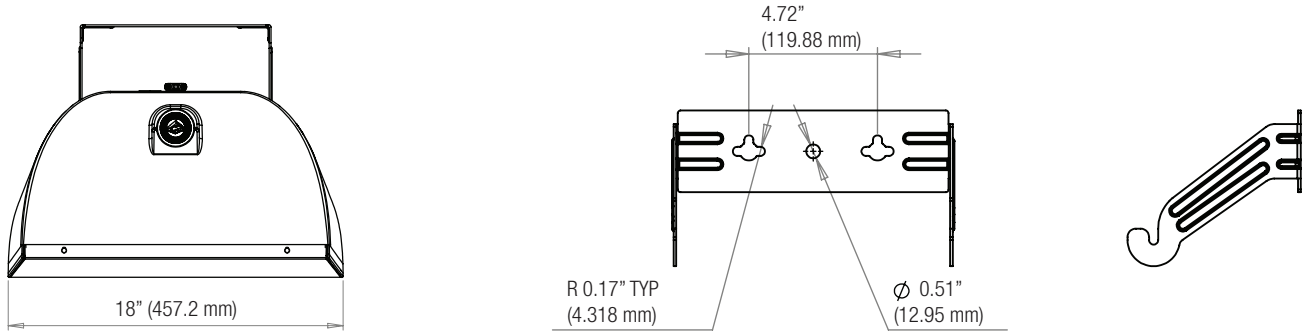

Front

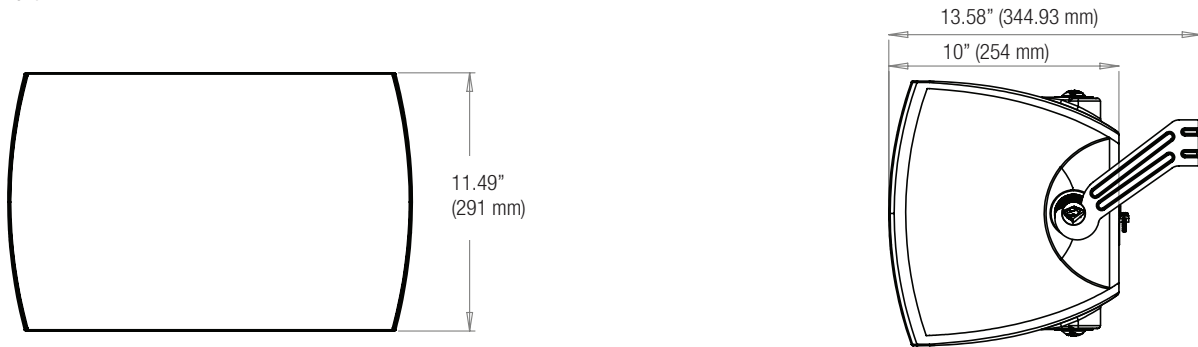

Plots

125 Hz

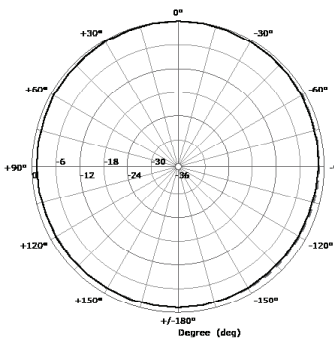

250 Hz

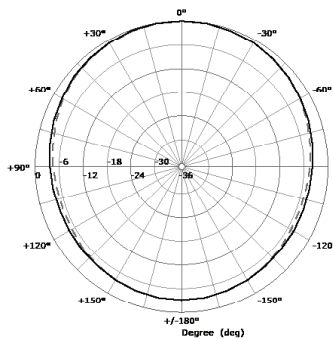

500 Hz

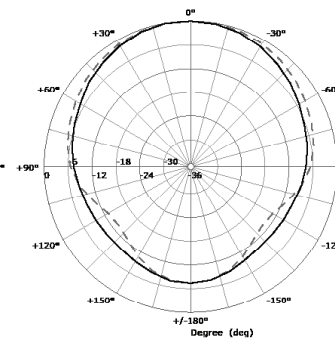

1,000 Hz

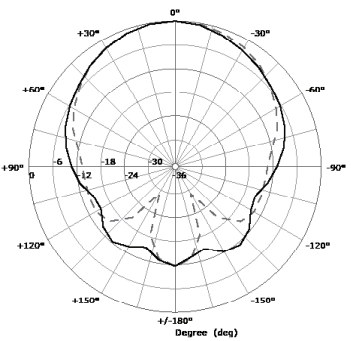

2,000 Hz

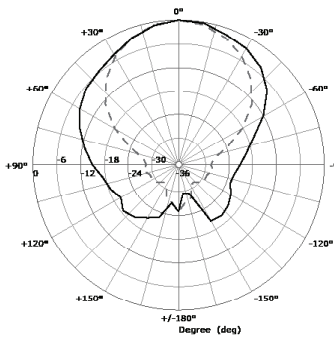

4,000 Hz

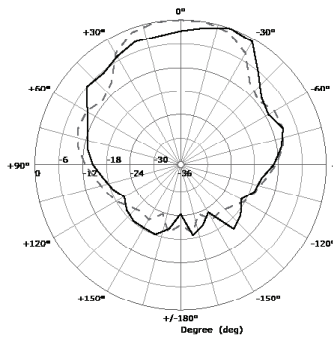

8,000 Hz

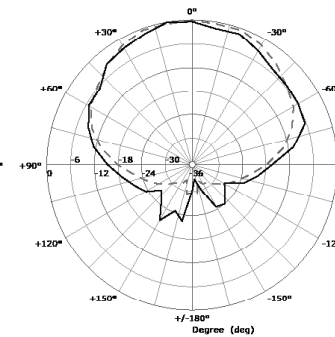

10,000 Hz

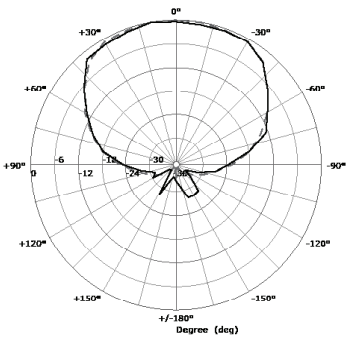

Graphs

Frequency Response

(dB) Level, Sound pressure

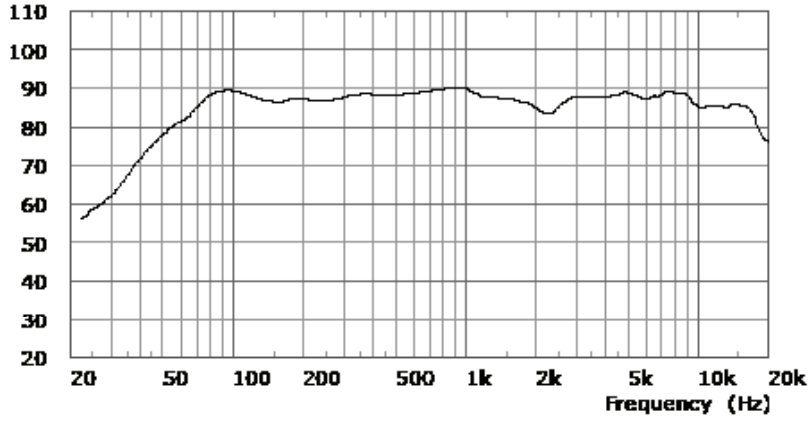

Vertical Beamwidth

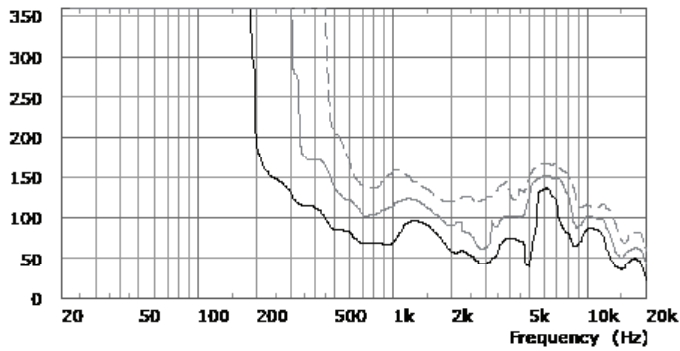

Directivity Index (DI)

