

# WB21-2S

## WALL BOX 21 FOR TWIN STUD WIDTH

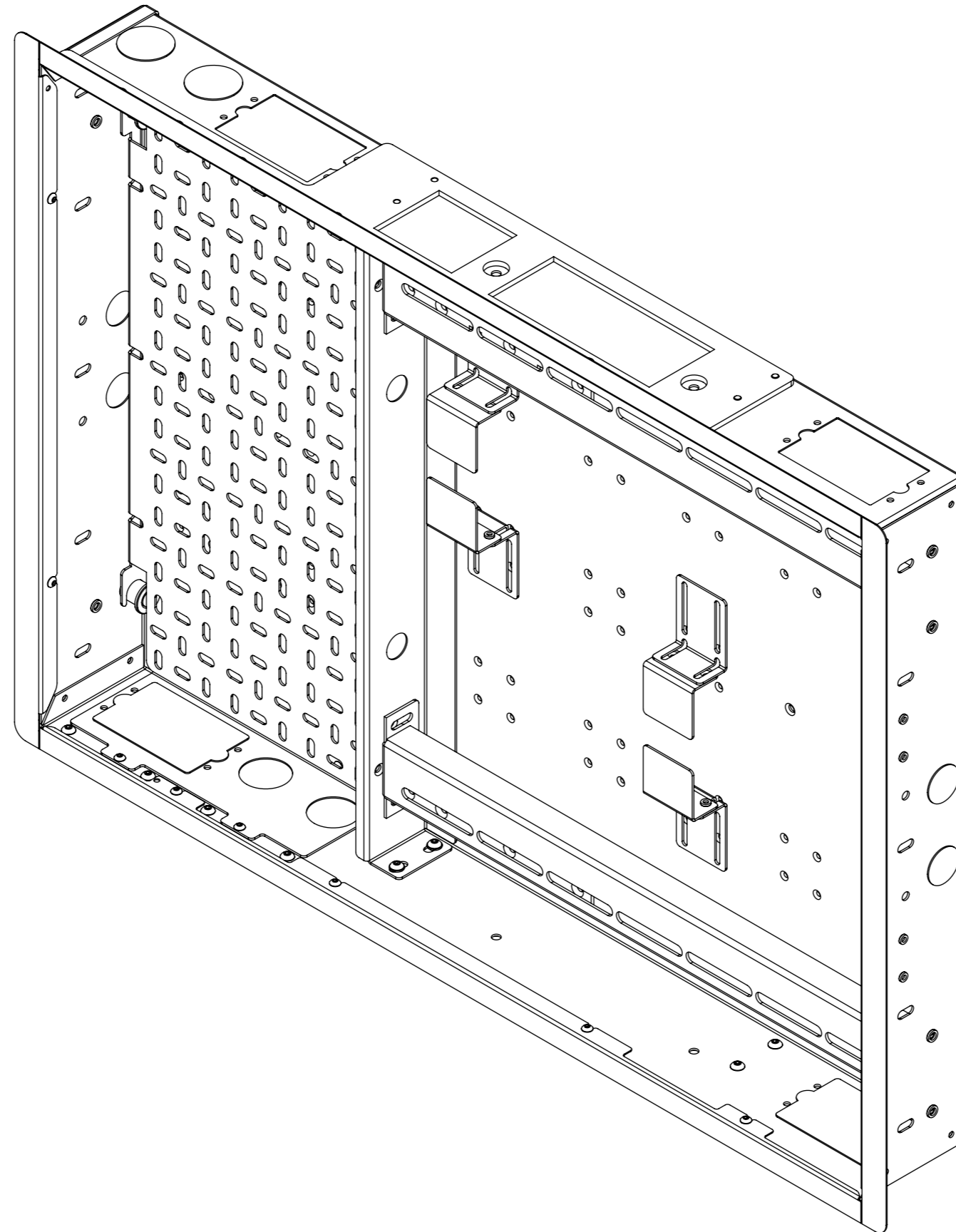

future automation



# WB21-2S

## WALL BOX 21 FOR TWIN STUD WIDTH



future automation

SPECIFICATION	MEASUREMENTS
Product Dimensions (in wall)	760mm [29 15/16"] W x 537mm [21 2/16"] L x 97mm [3 13/16"] D
PS Bracket Compatilby	PS40
Packaging Dimensions	870mm [34 4/16"] W x 650mm [25 9/16"] L x 180mm [7 1/16"] D
Shipping Weight	20Kg [45lb]
Product Options / Features	Custom RAL paint finishes, WB26-2S, WB31-2S
Package Contents	Wall box with 'hook on' mount plate, 2 x Pairs of clamp brackets, 2 x PS bracket mount rails, 4 x Horizontal trim strips, 2 x Vertical trim strips, 1 x WattBox mount bracket set
Marine Suitable	No

# WB21-2S

## WALL BOX 21 FOR TWIN STUD WIDTH

### DIMENSIONS

Contents include:

- Wall box
- 2 x Pairs of clamp brackets
- 2 x PS bracket mount rails
- 2 x Horizontal trim strips
- 2 x Vertical trim strips
- 1 x WattBox mount bracket set

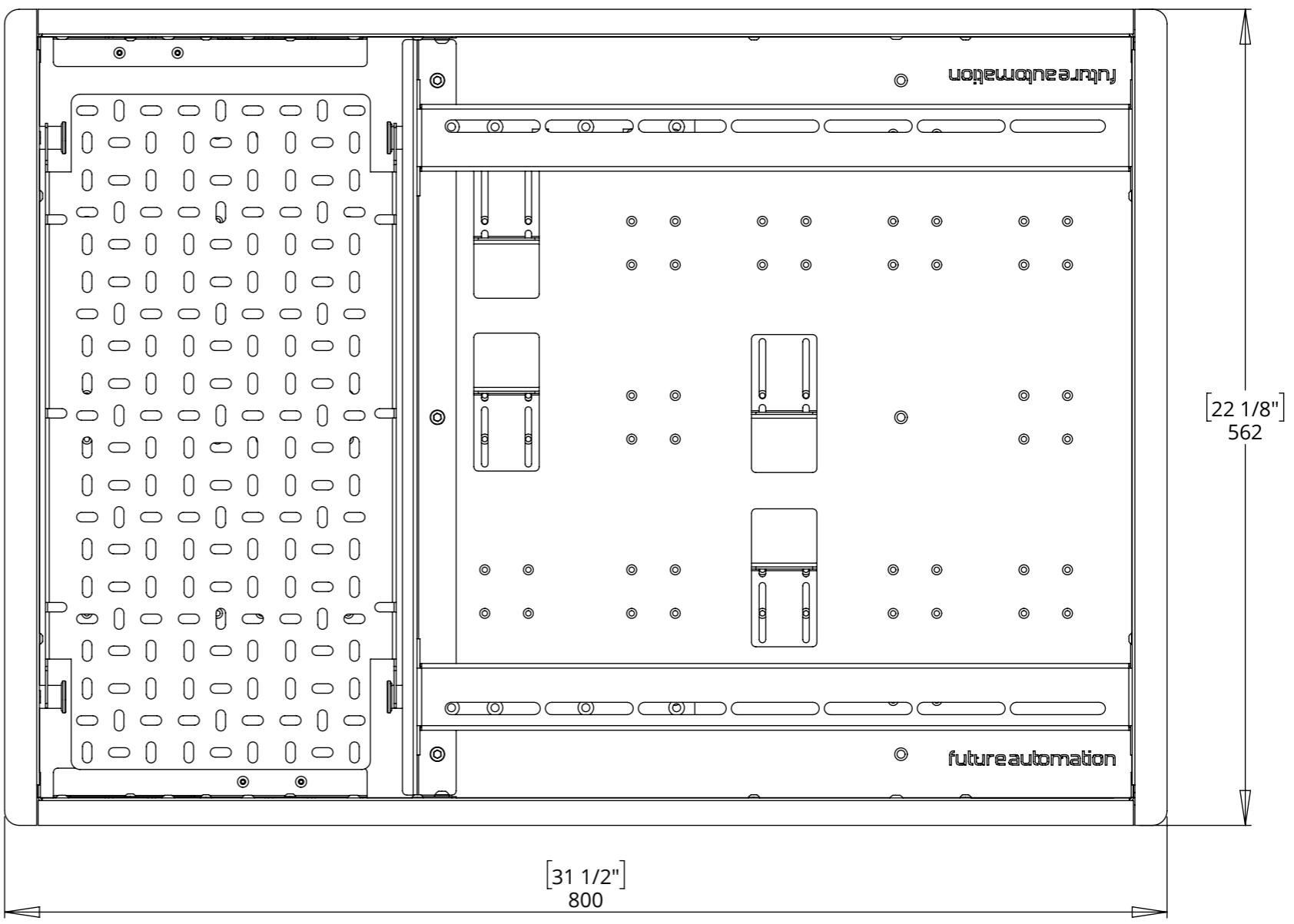
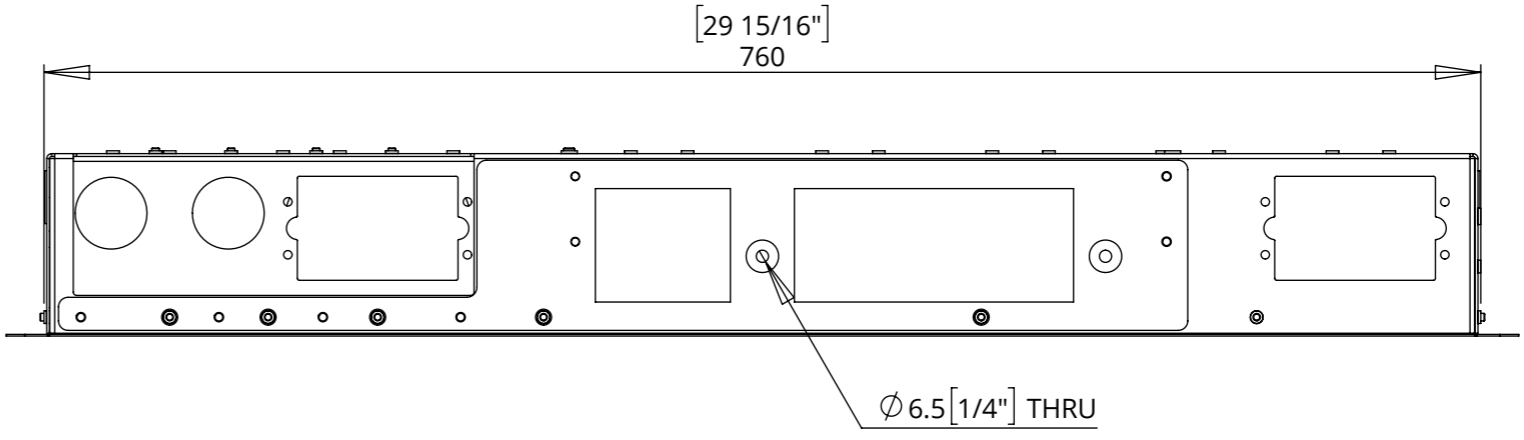
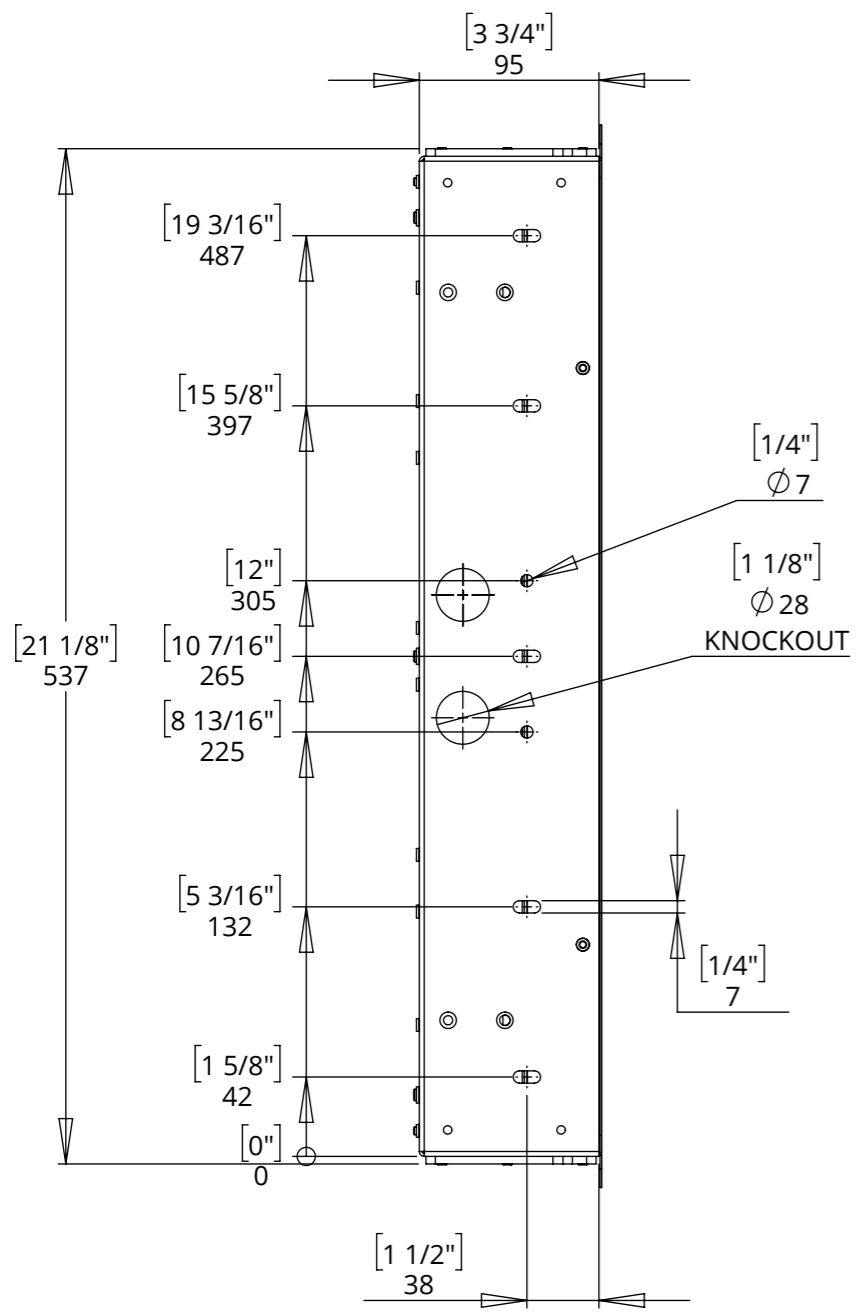

# WB21-2S WALL BOX 21 FOR TWIN STUD WIDTH



## ACCESSORY MOUNTING FEATURES

The WB21-2S features adjustable accessory clamps and a large mounting spaces that means it is perfectly suited to a wide variety of AV accessories.

The removable plate and provided mounting brackets allow the WattBox WB-200/300VB to be mounted into the lower face of any size Wall Box.

These include:

- Samsung One Connect
- Power conditioners e.g BlueBolt SM-3 Pro
- Baluns
- Small audio converters
- Apple TV
- Roku
- SnapAV OVRc compact power conditioner

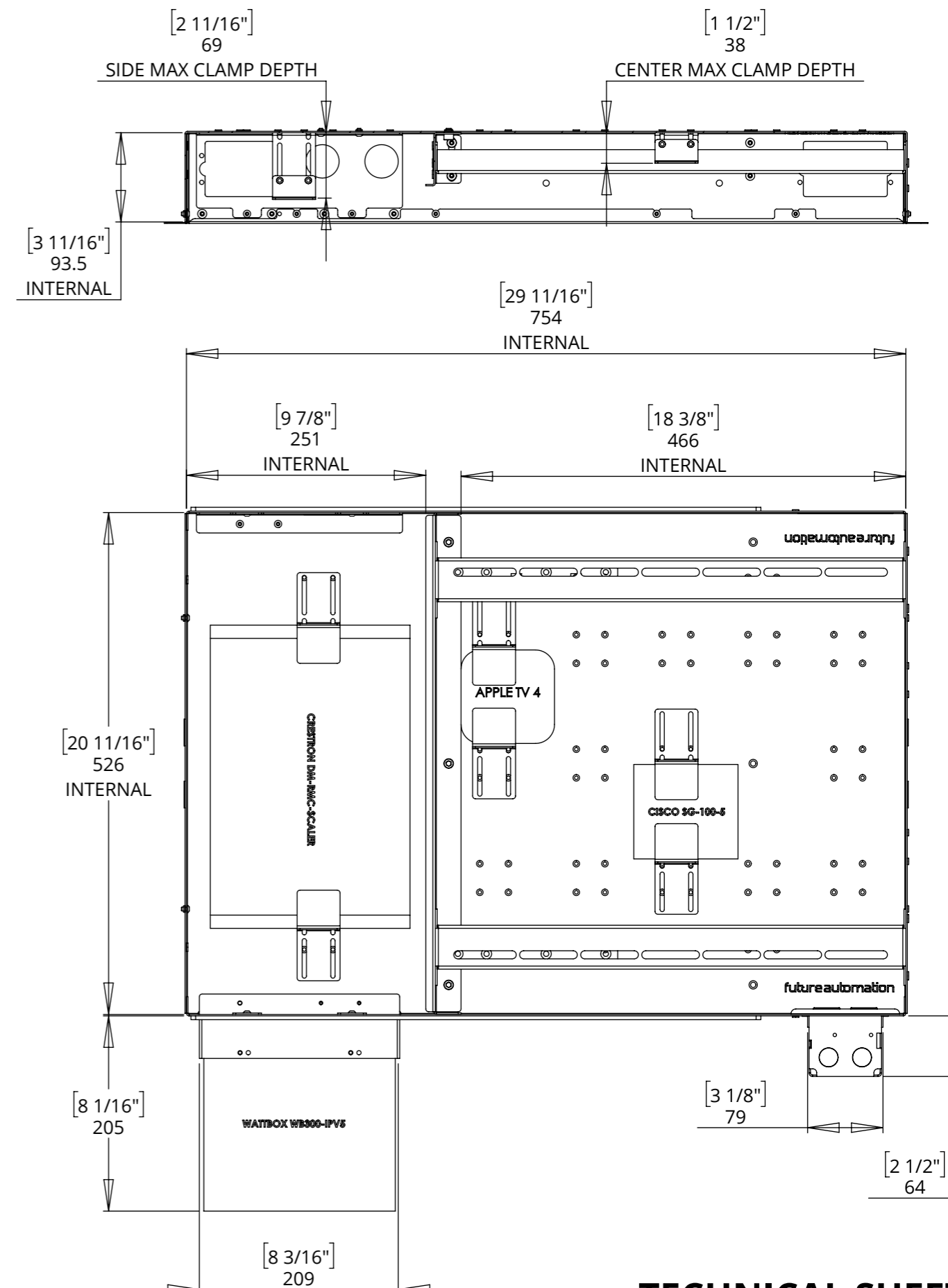
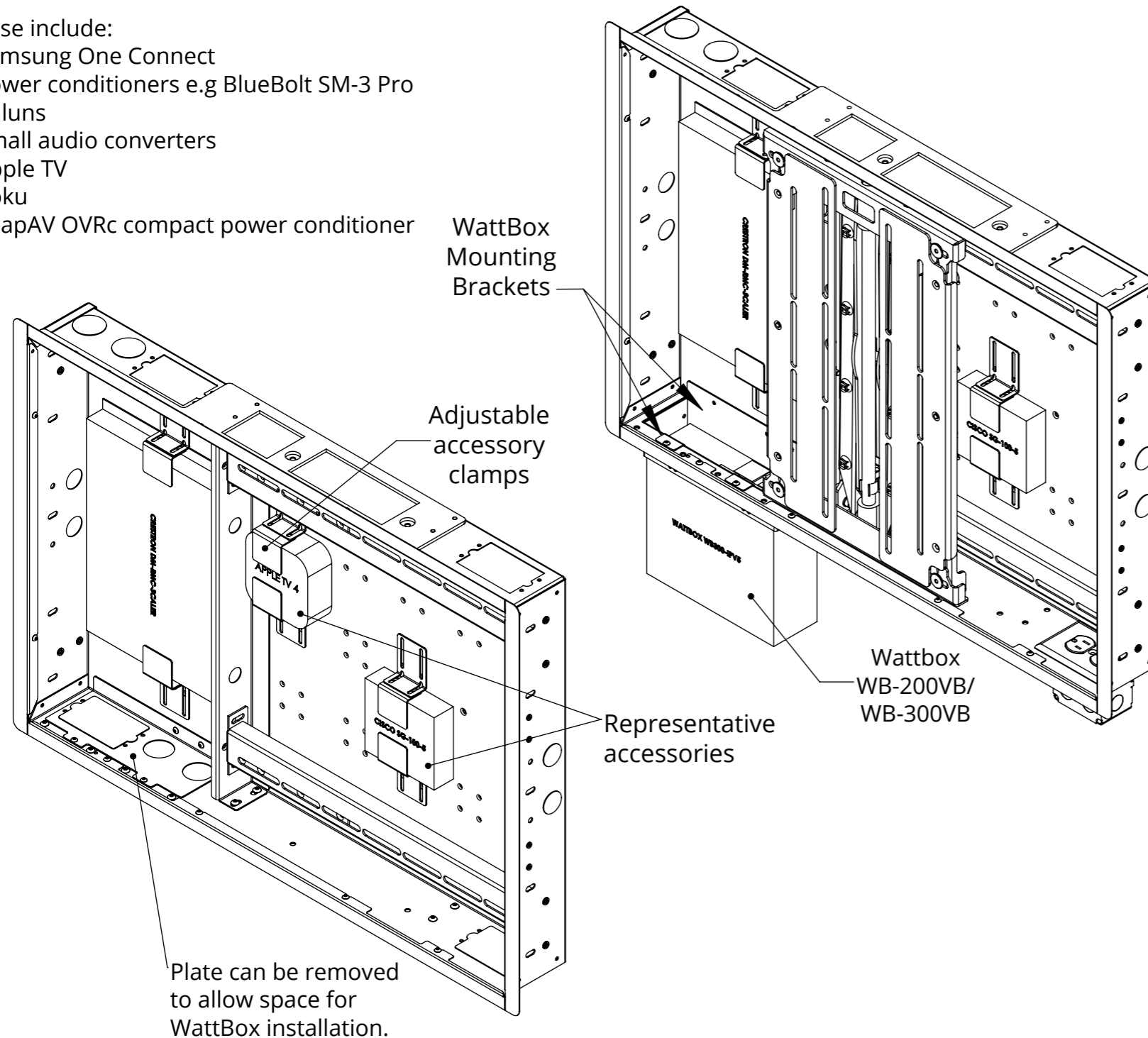

# WB21-2S

## WALL BOX 21 FOR TWIN STUD WIDTH



### ACCESSORY MOUNTING FEATURES

The WB21-2S also features a removable accessory plate to which accessories can be cable tied to both sides. This plate has two fixed positions to suit a wide variety of AV accessories.

In order to access the removable plate for WattBox mounting, the accessory plate will need to be removed by pulling the top forward, and lifting out of the wall box.

ACCESSORY PLATE

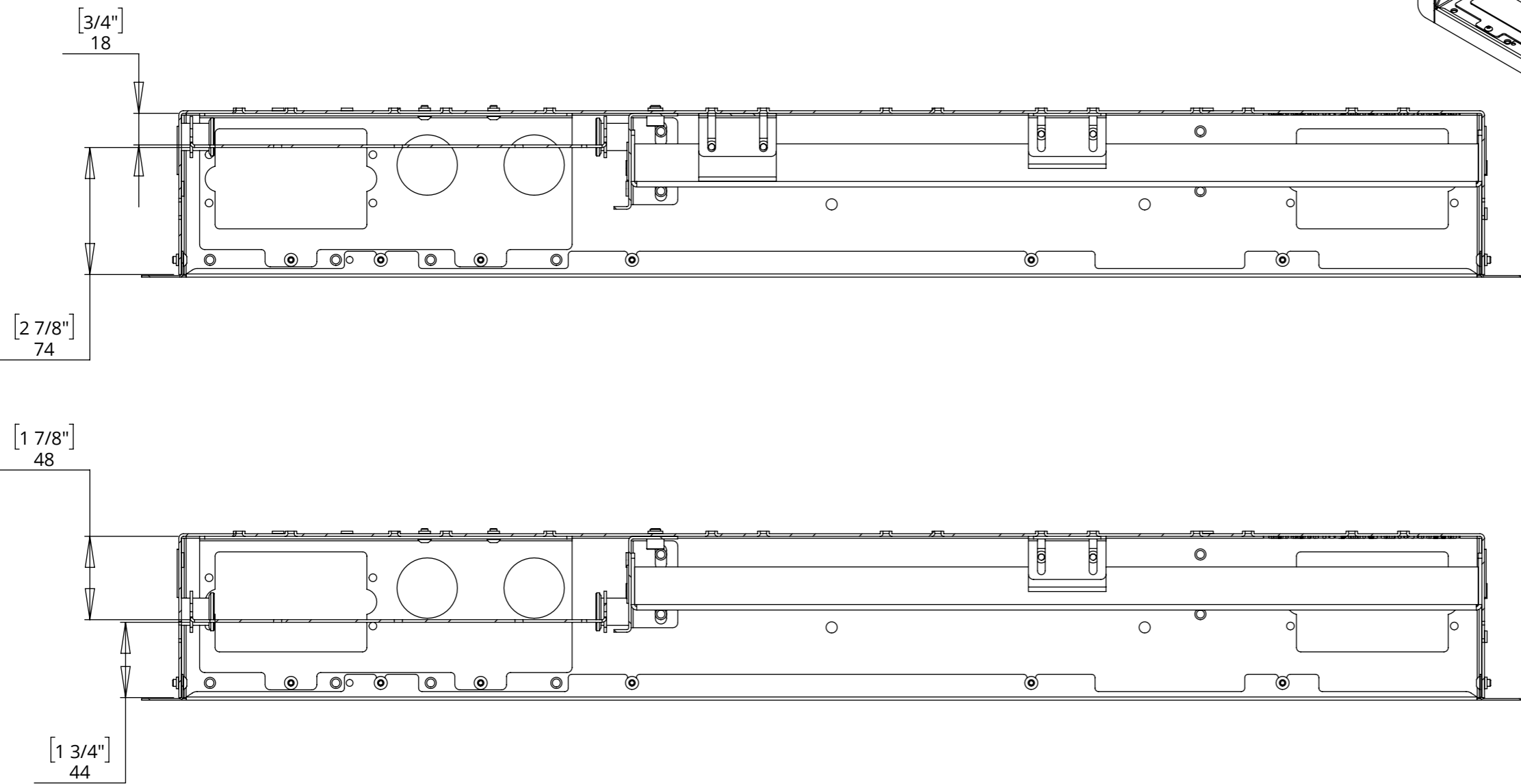
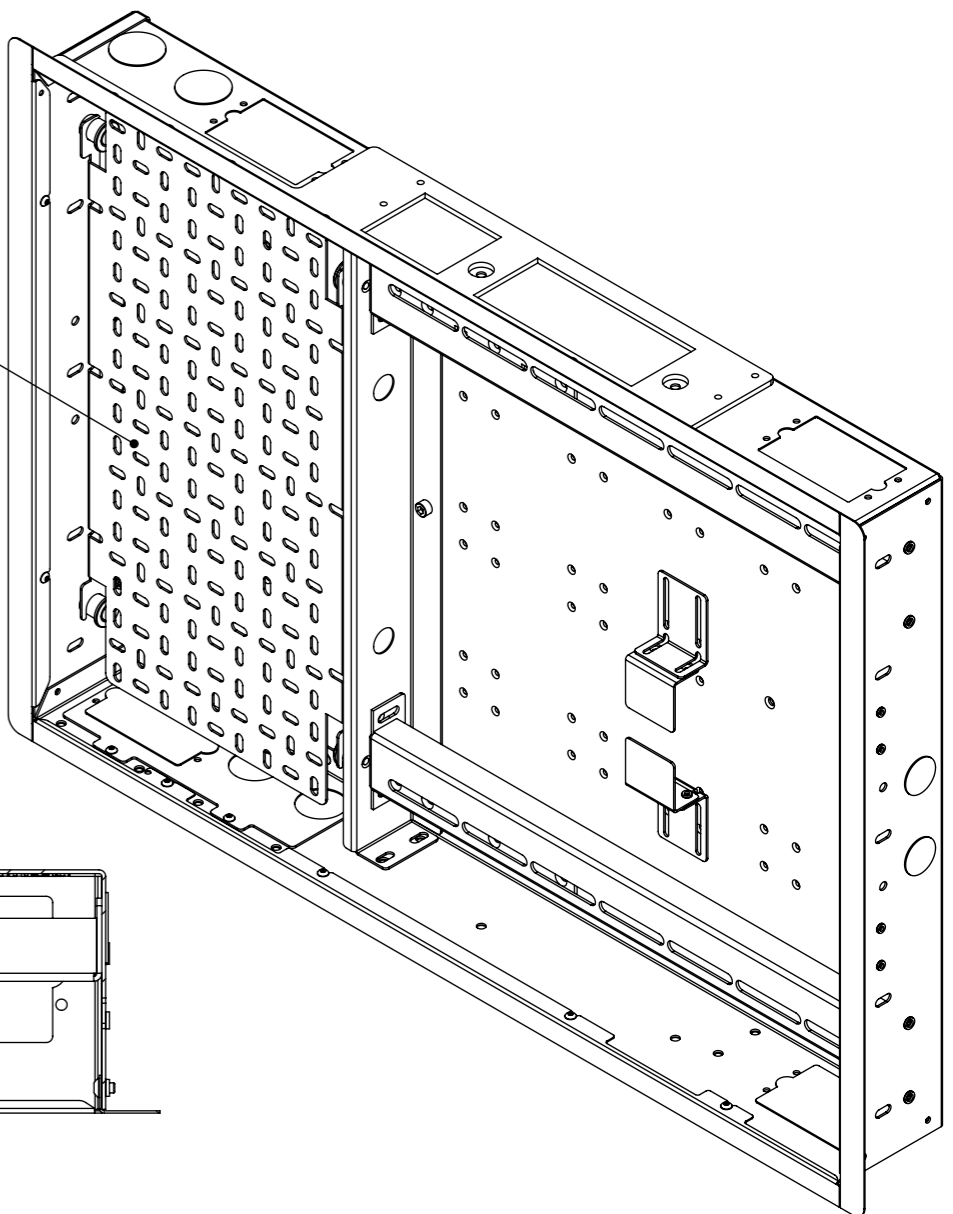

# WB21-2S

## WALL BOX 21 FOR TWIN STUD WIDTH



### ONE CONNECT BOX MOUNTING

#### 2020 One Connect Box

The 2020 One Connect Box can be secured to the Accessory mount plate in the smaller accessory bay.  
The provided Clamp Brackets can be used to secure additional accessories inside the larger accessory bay.

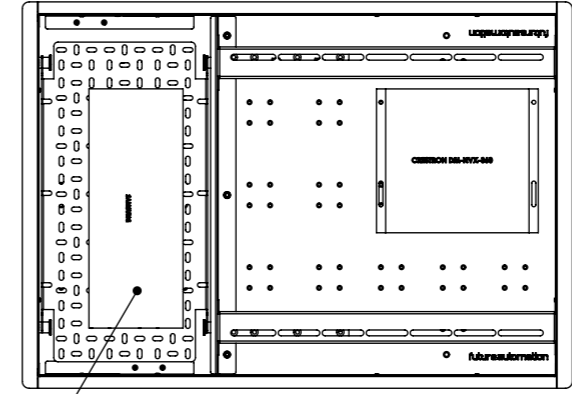
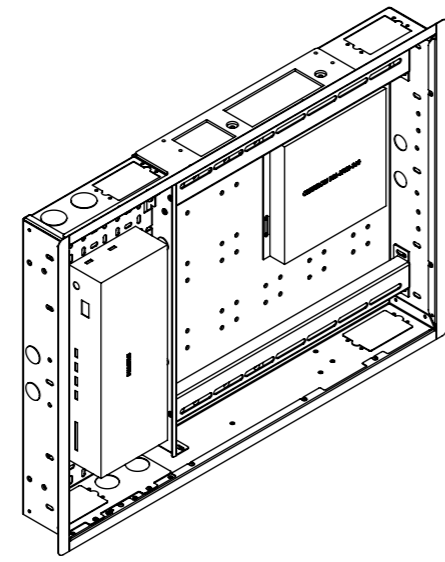

2020 One Connect Box

#### 2021 Slim One Connect Box

The provided Clamp Brackets can be used on the side of the box to secure the 2021 Slim Samsung One Connect Box inside the larger accessory bay.  
Note. The 2021 Slim One Connect Box will rest on the lower Mount Rail and will sit partially behind the PS bracket.

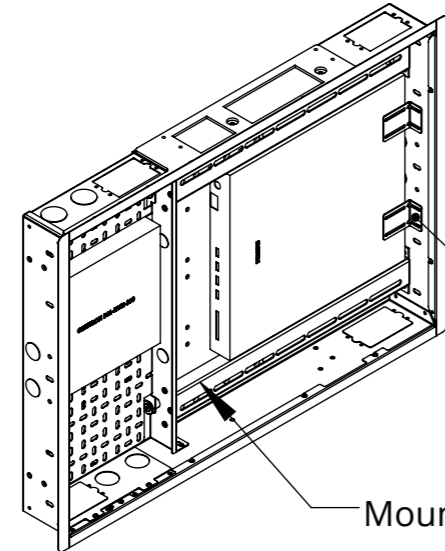

Adjustable accessory clamps

Mount Rail

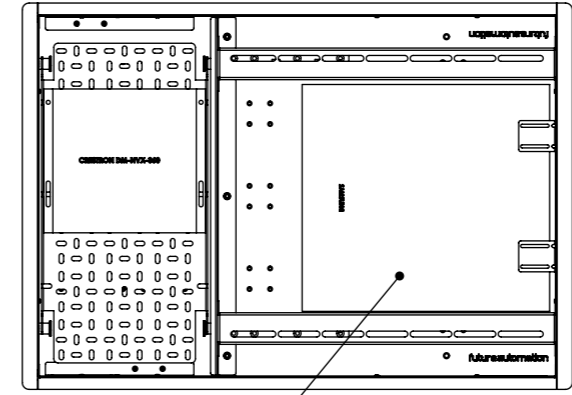

2021 Slim One Connect Box

# WB21-2S

## WALL BOX 21 FOR TWIN STUD WIDTH

### PS BRACKET INSTALLATION FEATURES

#### LATERAL ADJUSTMENT

The bracket mount rail has slots on the front face to allow the PS bracket to shift laterally so that its location relative to the studs can be fine tuned.

The larger shift side can be to the left or right depending on wall box orientation. Rotate the wall box 180° to determine shift direction.

Shown below with the Future Automation Logo and shift to the right.

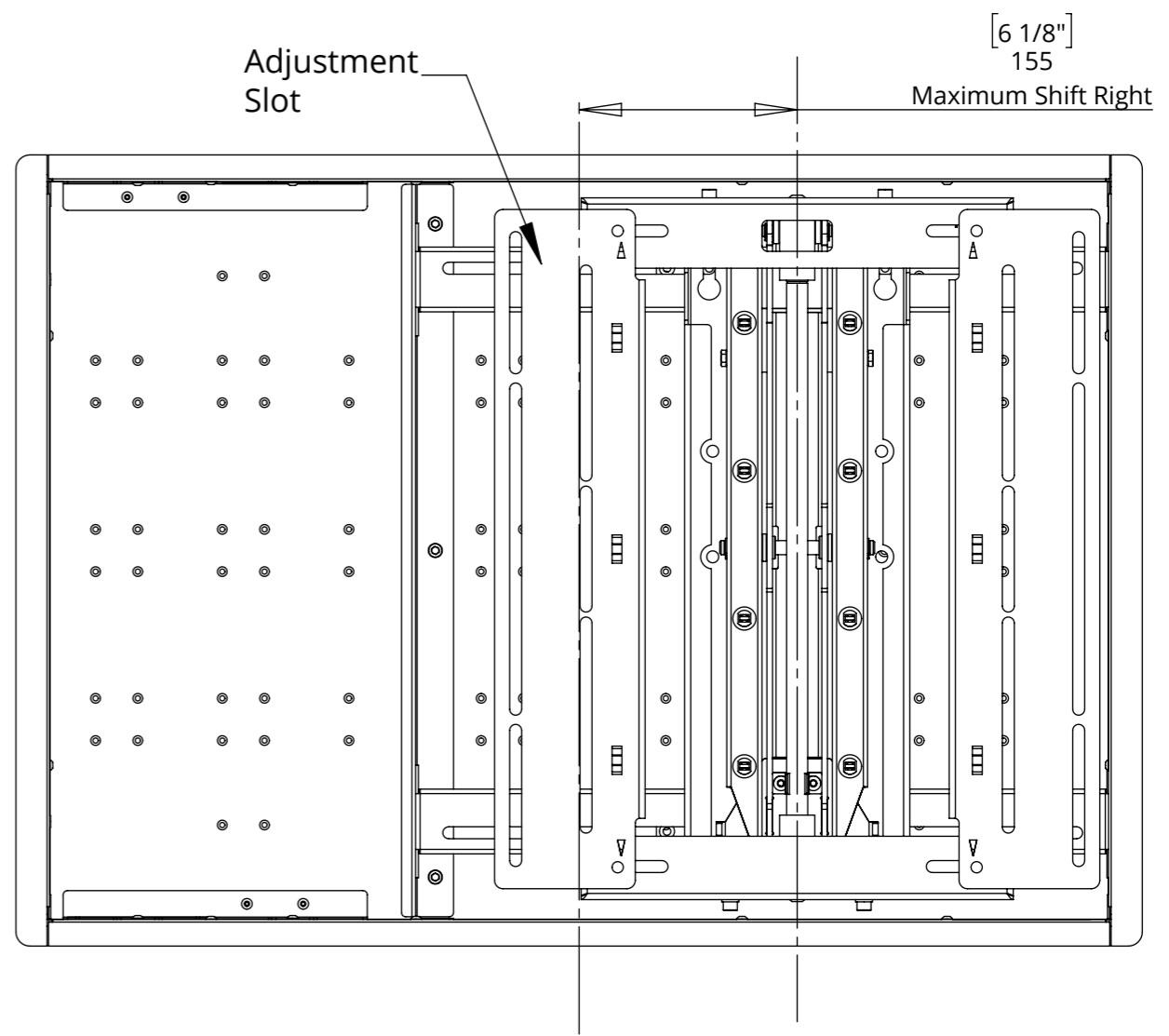
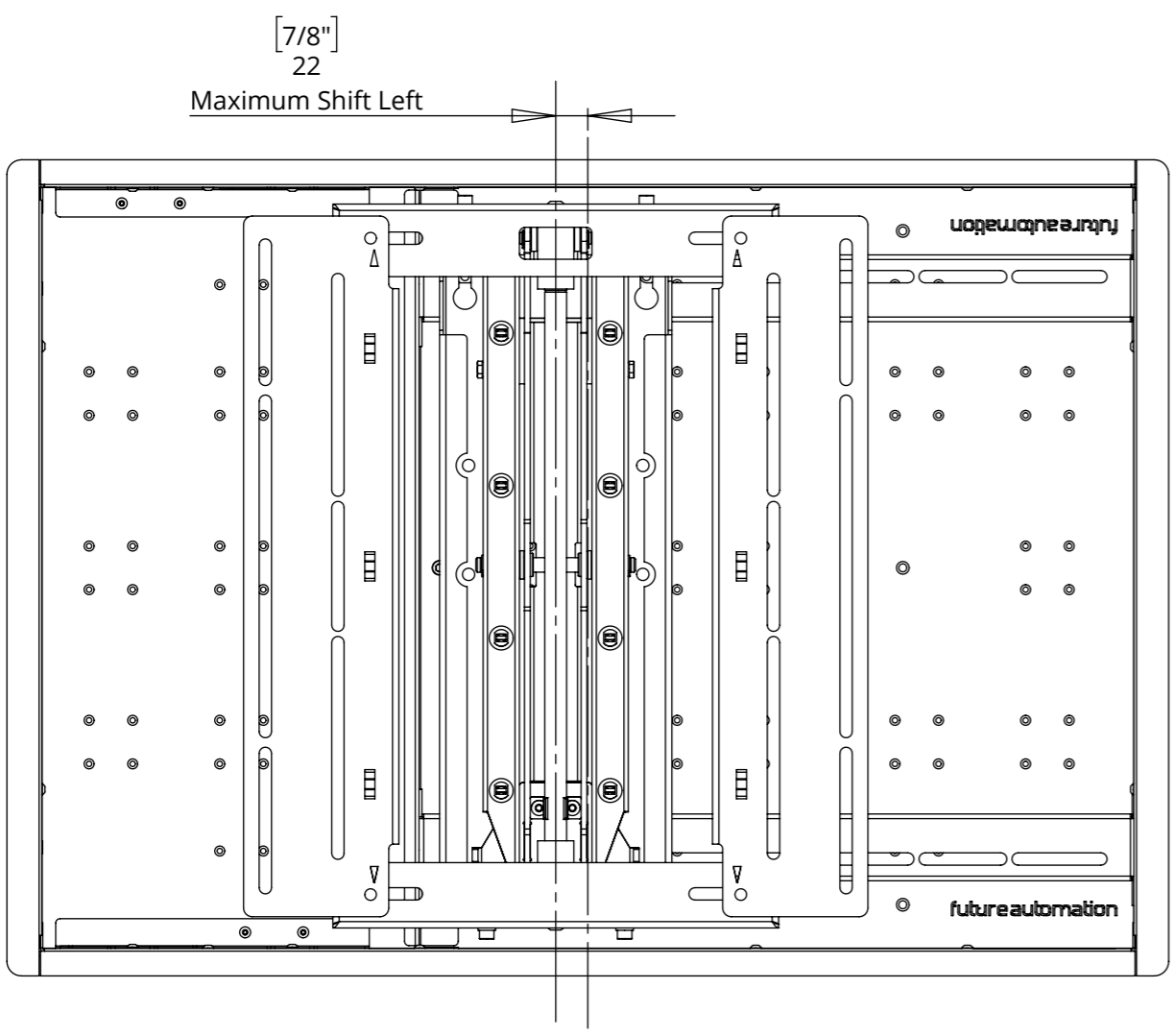

# WB21-2S

## WALL BOX 21 FOR TWIN STUD WIDTH

### PS40 BRACKET MOUNTING

The PS40 has one central mounting position within the WB21-2S wall box.

