

UBLS EBF

UNDER BED LIFT SWIVEL & END OF BED FLAP

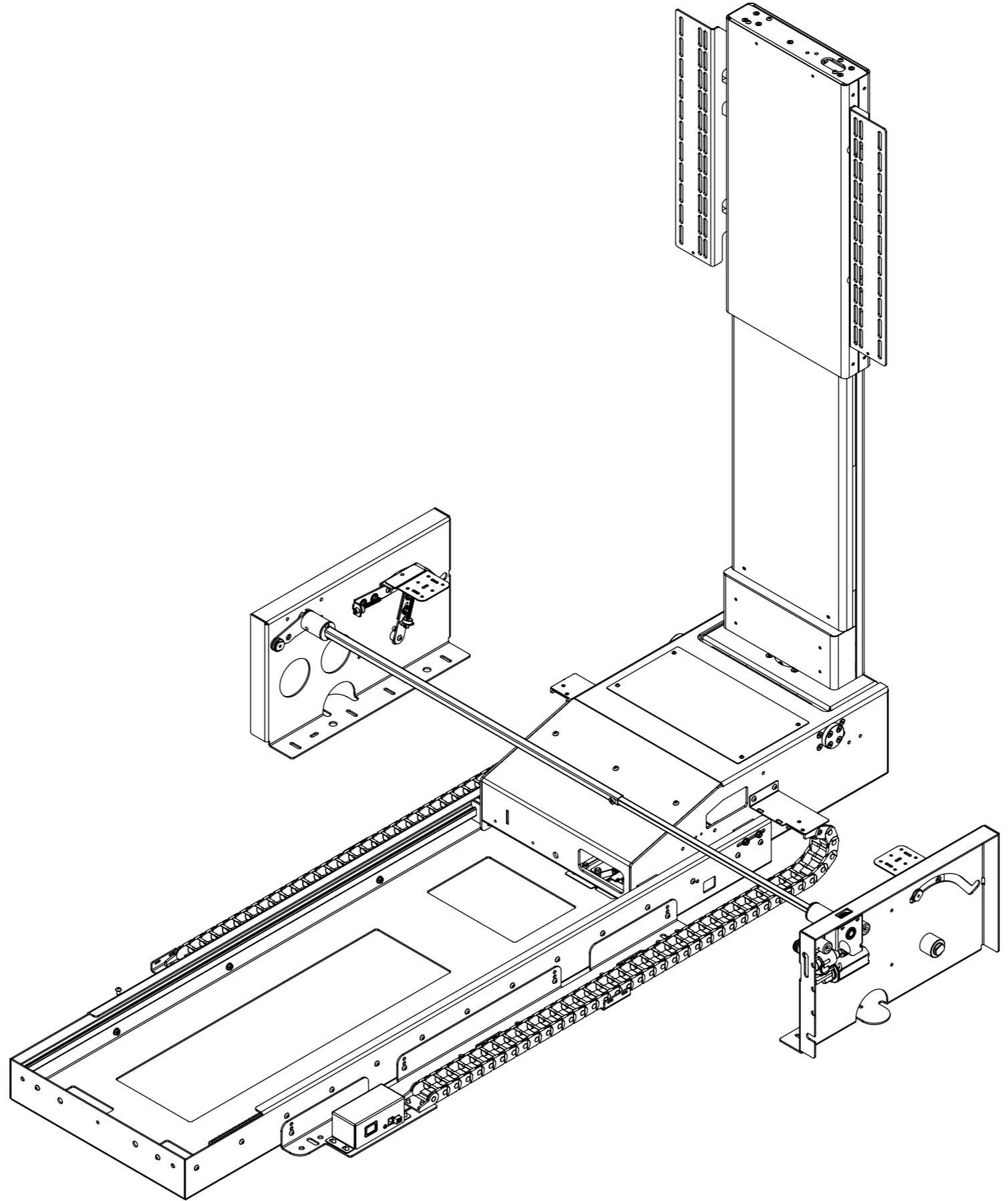

future automation



SPECIFICATION	MEASUREMENTS
Product Dimensions	1560mm (61.42") x 695mm (27.36") x 220mm (8.66")
Maximum Screen Size	1250mm (49.21") x 800mm (31.49") x 70mm (2.75")
Maximum Weight Capacity	40Kg (88lbs)
Minimum Height Required	320mm (12.59")
Minimum Length Required	1800mm (70.86)
Product Weight	85Kg (187lbs)
Packaging Dimensions	1660mm (65.35") x 810 (31.88") x 510mm (20.07")
Shipping Weight	150Kg (331lbs)
Maximum Rotation	180° - Both directions
Movement Type	Motorised
Power Supply Required	110V - 240V AC
Power Consumption Max.	100W
Power Consumption Standby	1.5W
Mounting Patterns Supported	VESA 400, 300, 200 W x 400, 300, 200 H
Control Options	IR Remote, RS232
Product Options / Features	Specific B&O and Loewe mounts / adapters, Custom RAL paint finishes, Marine suitable version
Package Contents	Mechanism, IR remote control
Marine Suitable	No

UNDER BED LIFT SWIVEL & END OF BED FLAP

Design Highlights

Sophisticated electronics allow for favourite viewing height to be programmed via the IR remote control.

The electric flap retracts in under the bed. The Under Bed Lift & Swivel (UBLS) mechanism is then activated to reveal the screen.

This method of flap movement gives the neatest possible look as there is no flap panel left visible once the screen is in the viewing position.

Mechanism allows bottom of screen to be elevated up to 950mm [37.5"] above the floor.

All the power and signal cables for screen and mechanism can be concealed within the mechanism

Quiet and smooth action from under bed to maximum movement.

Standard mechanism screen mount suitable for VESA 400x400, 400x300, 300x300, and 200x200 mounting.

An advance control system allows the lift mechanism to be easily controlled via home automation systems such as Crestron and AMX. Two way communication is also possible via RS232.

Many mounting options available for Loewe and Bang & Olufsen screens.

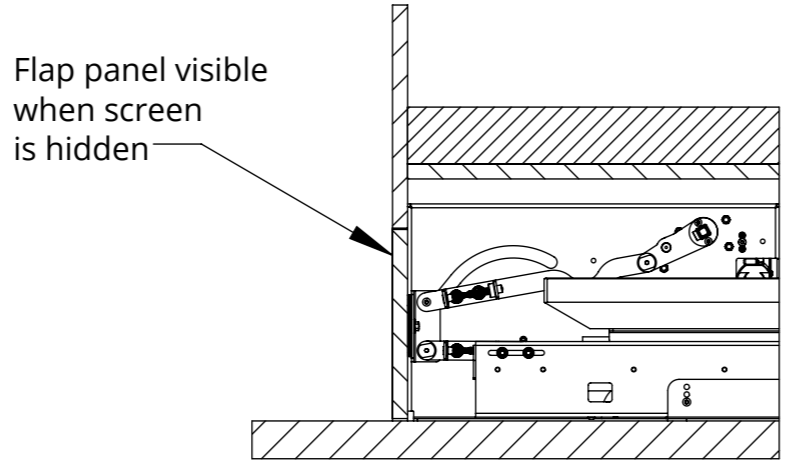
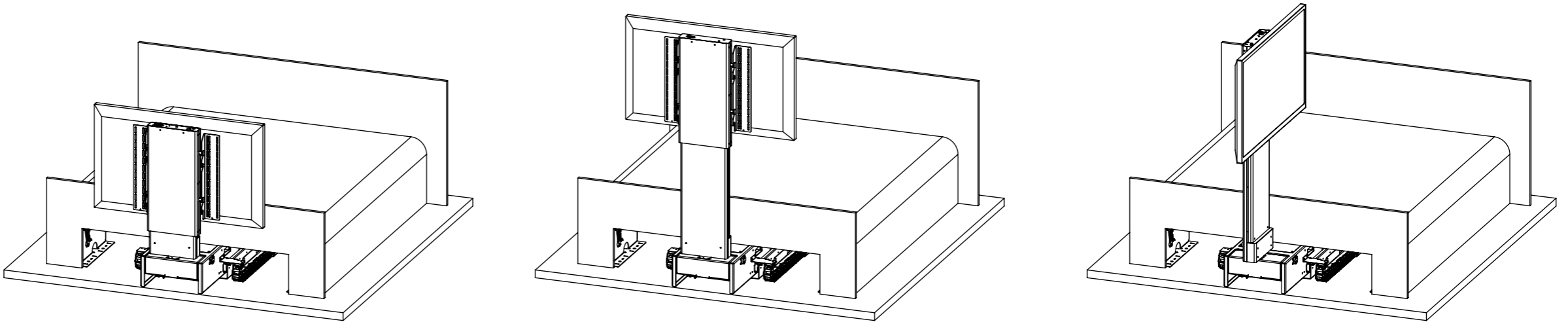
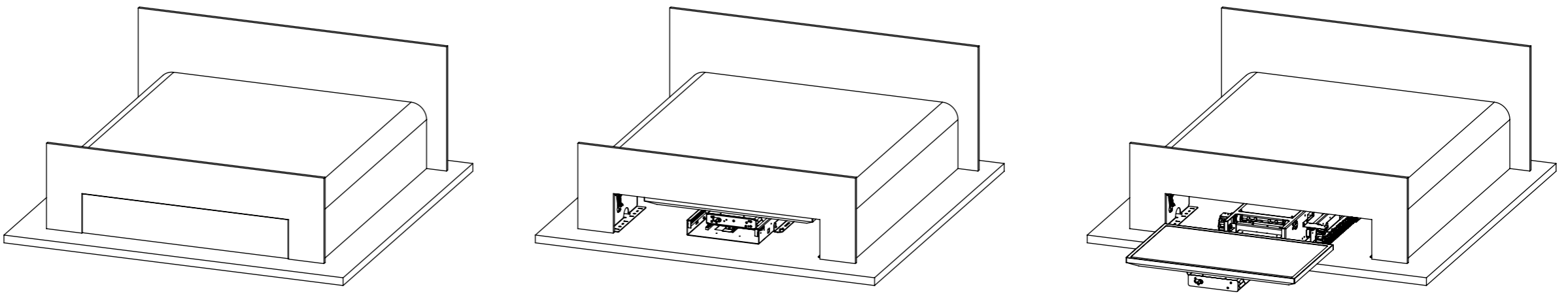

Flap panel visible when screen is hidden

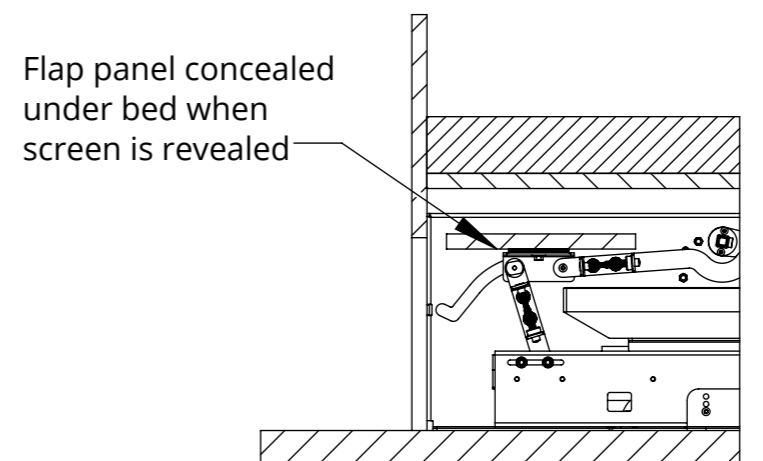

Flap panel concealed under bed when screen is revealed

UNDER BED LIFT SWIVEL & END OF BED FLAP

Flap Details

End of Bed Flap panel should be made from wood.

Flap panel needs to be screwed to flap attachments brackets at each side.

Maximum flap panel weight 6Kg [13lb].

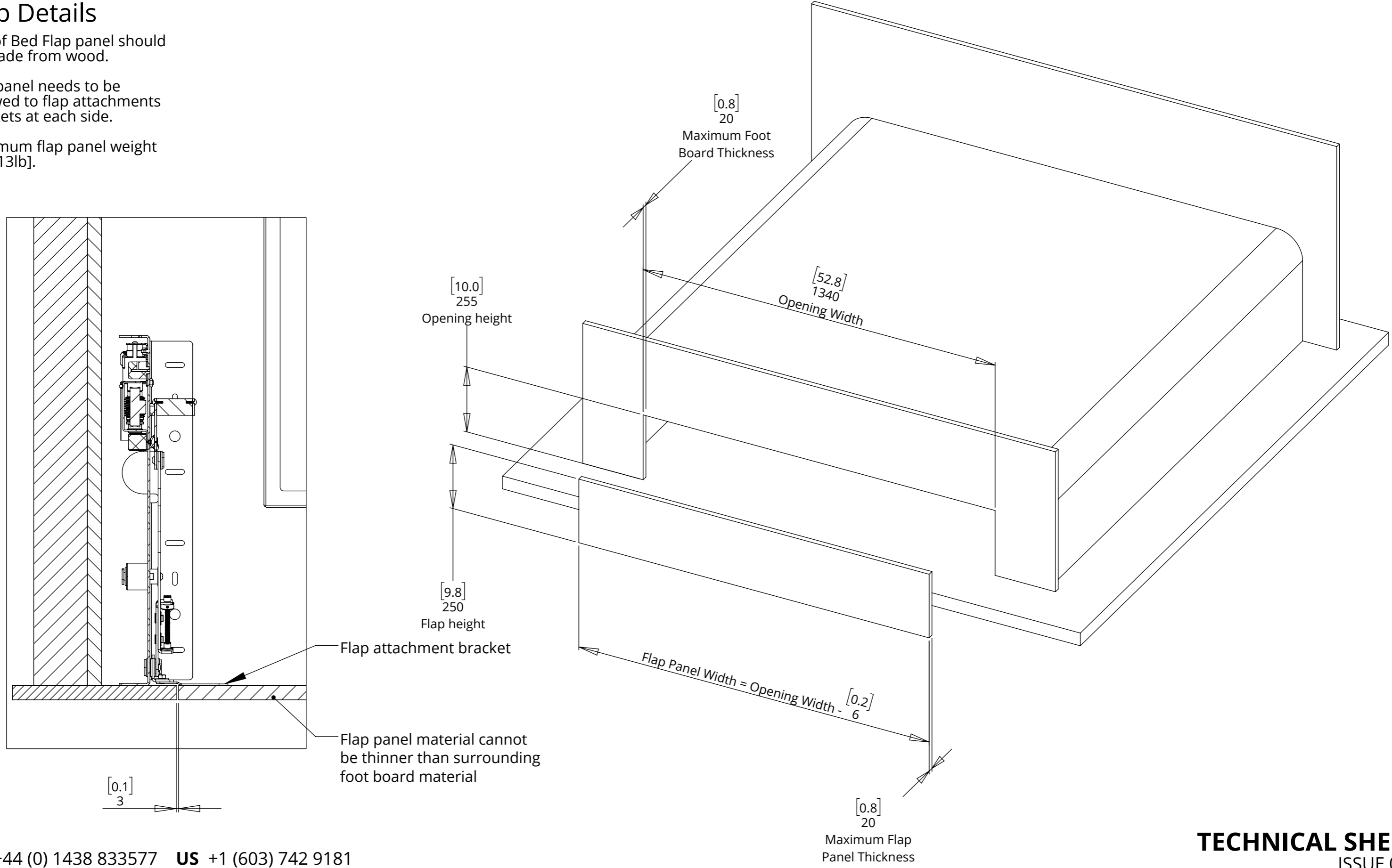

UNDER BED LIFT SWIVEL & END OF BED FLAP

End of Bed Space Details

At the end of the bed there needs to be enough space for the mechanism to extend from under the bed.

There needs to be a minimum of 'screen height + 12.5" / 318mm' at the end of the bed.

If the screen is being biased high on the screen mount to achieve even more elevation, then this end of bed space will need to be increased.

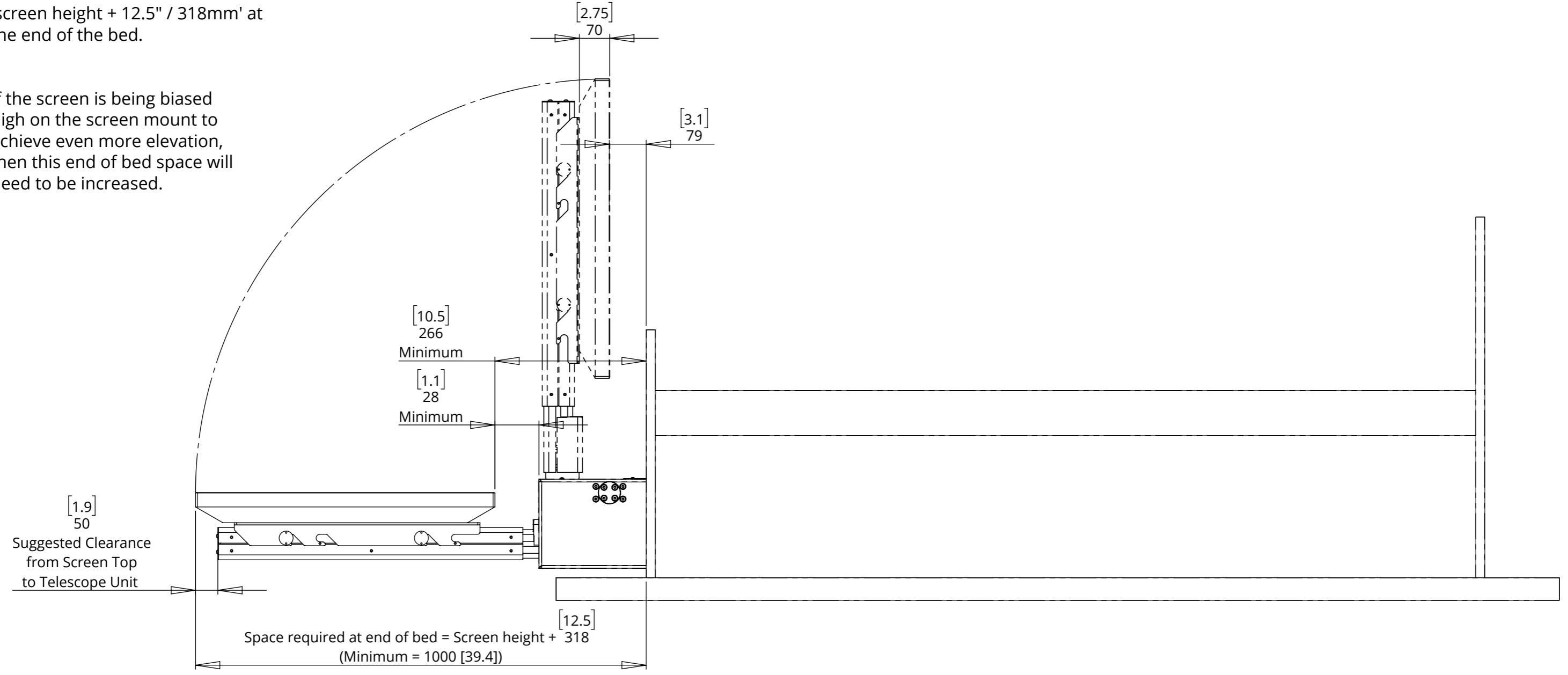

UNDER BED LIFT SWIVEL & END OF BED FLAP

Telescope Elevation Details

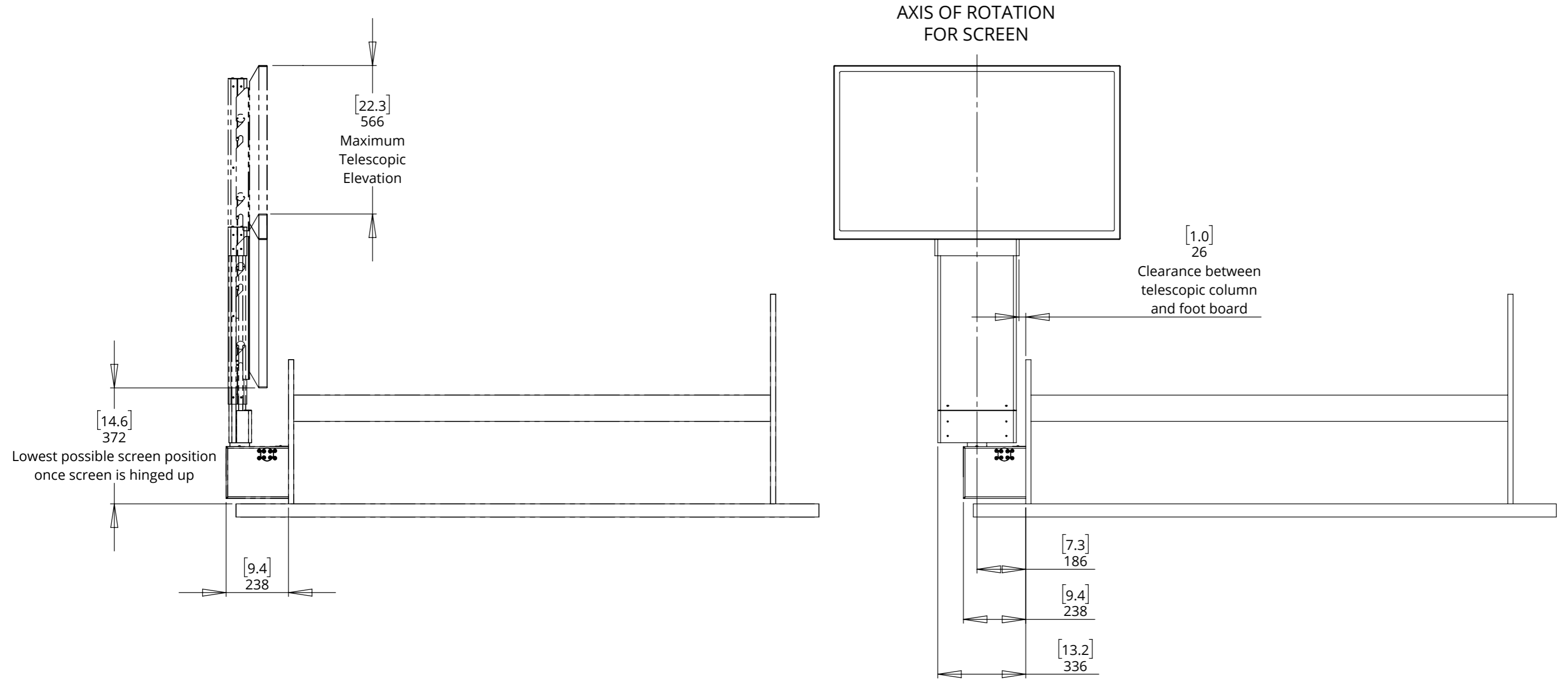

UNDER BED LIFT SWIVEL & END OF BED FLAP

Under Bed Space Details

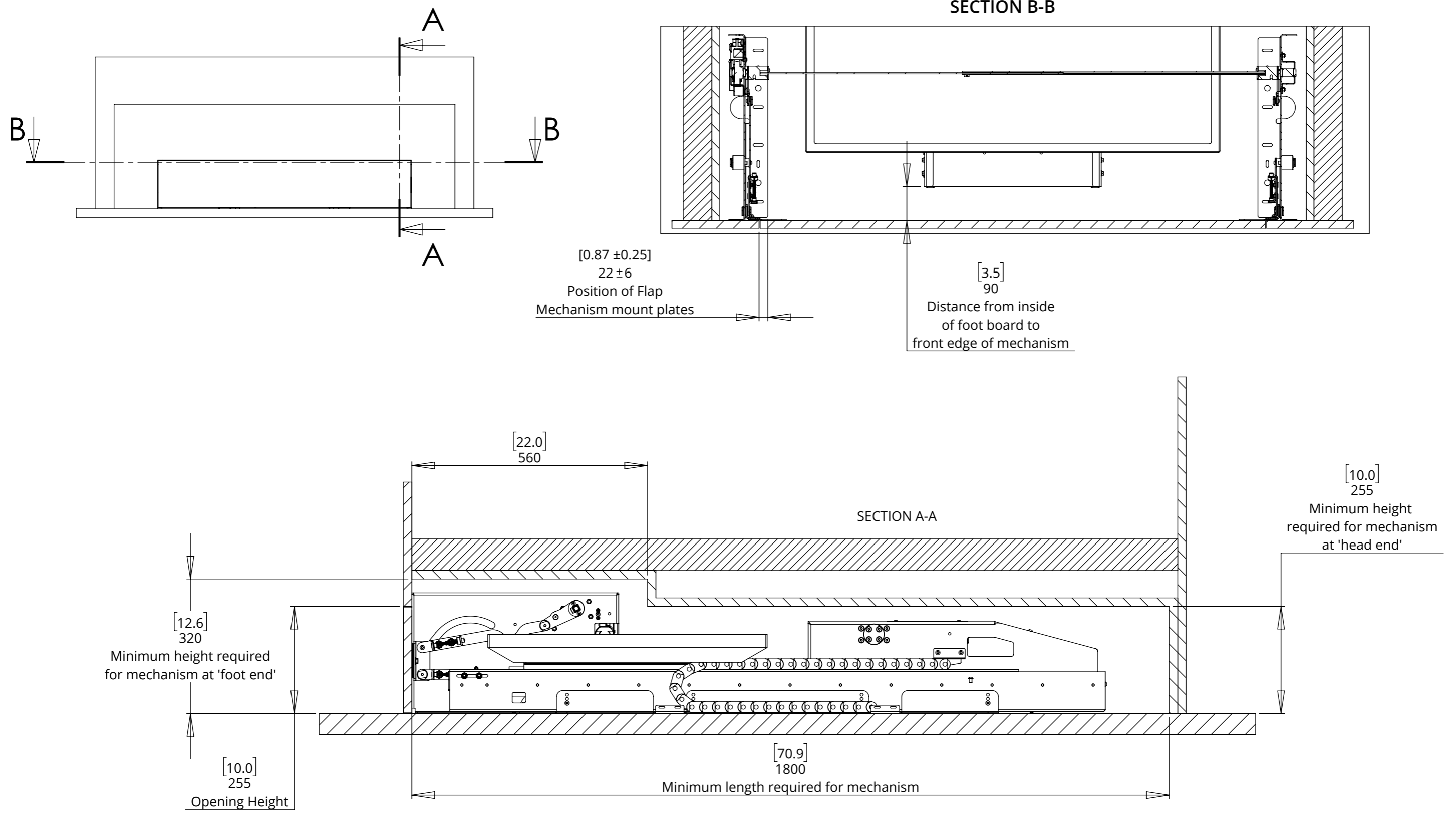

UNDER BED LIFT SWIVEL & END OF BED FLAP

Fixing Location Details

Areas outlined in red show areas where fixings need to be made to the floor below.

These areas should ideally be wooden surfaces so that the mechanism components can be screwed down in place.

For instances where the mechanism can't be attached to the floor a rear wall fixing can be provided

These areas also need access from above in order to get the fixings in place.

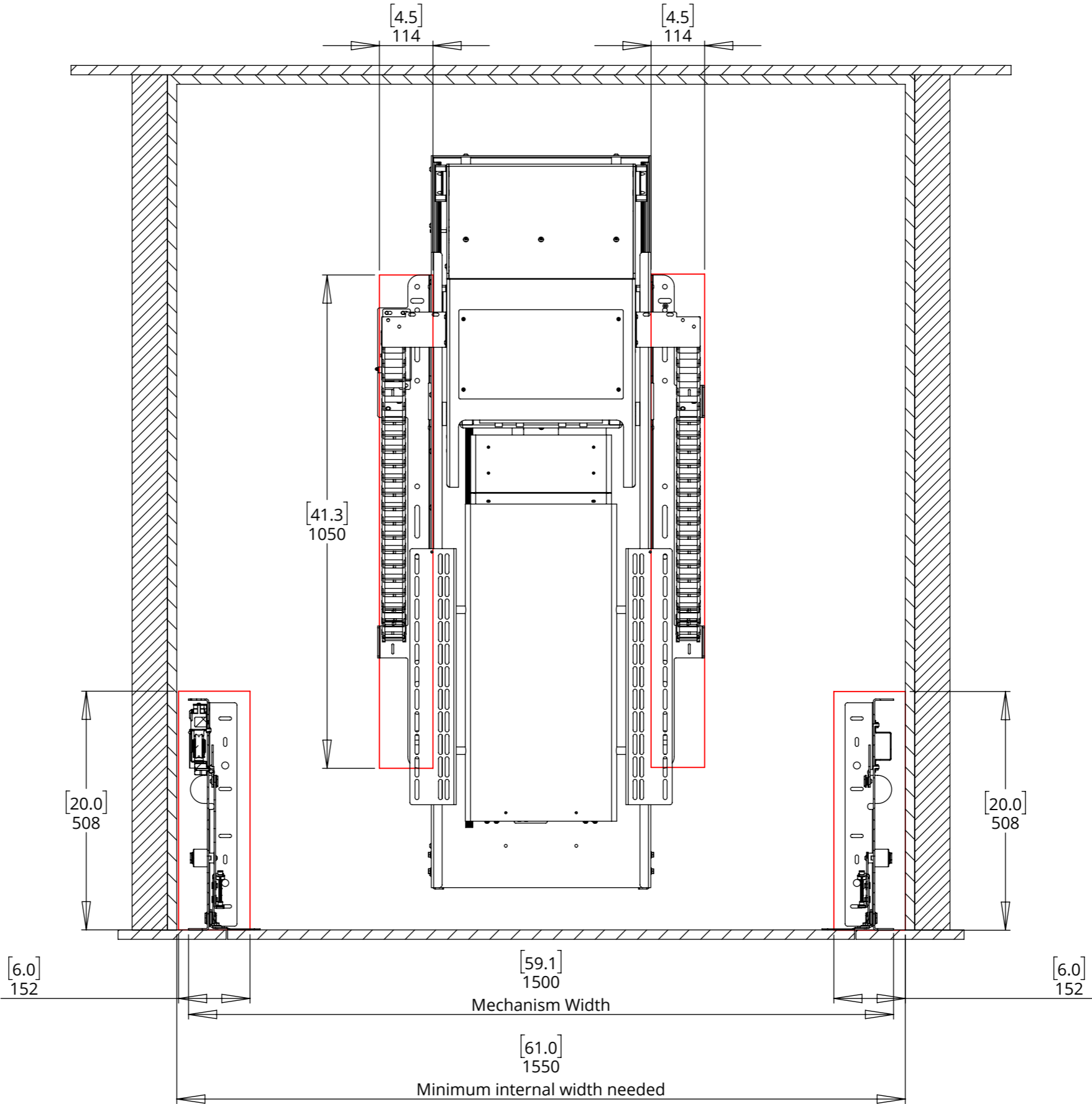

UBLS EBF



UNDER BED LIFT SWIVEL & END OF BED FLAP

Flap Fixing Details

Edge of Flap shown by red outline

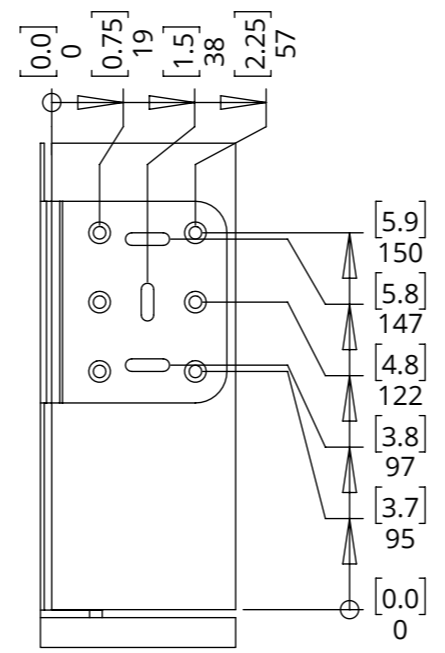
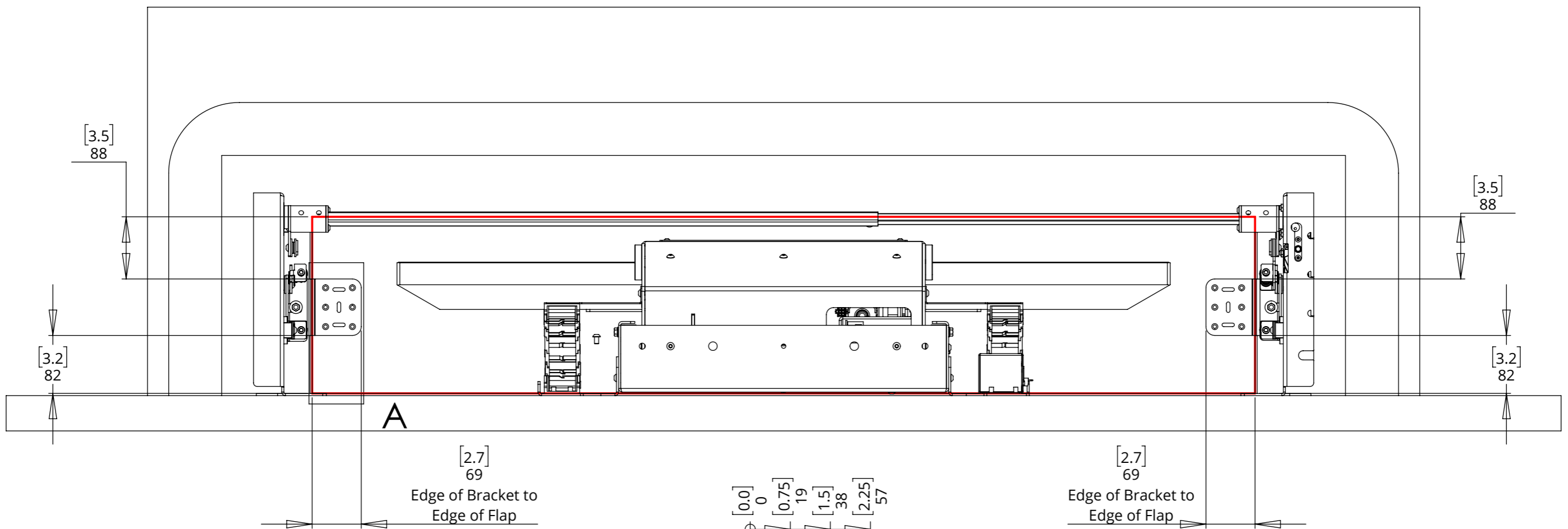

DETAIL A

Cable Management

Detail B shows the hole in which the end customers cabling will enter the mechanism after being passed through the cable management track.

Detail C shows the where the mains power, IR and ethernet cables will need to be inserted.

