

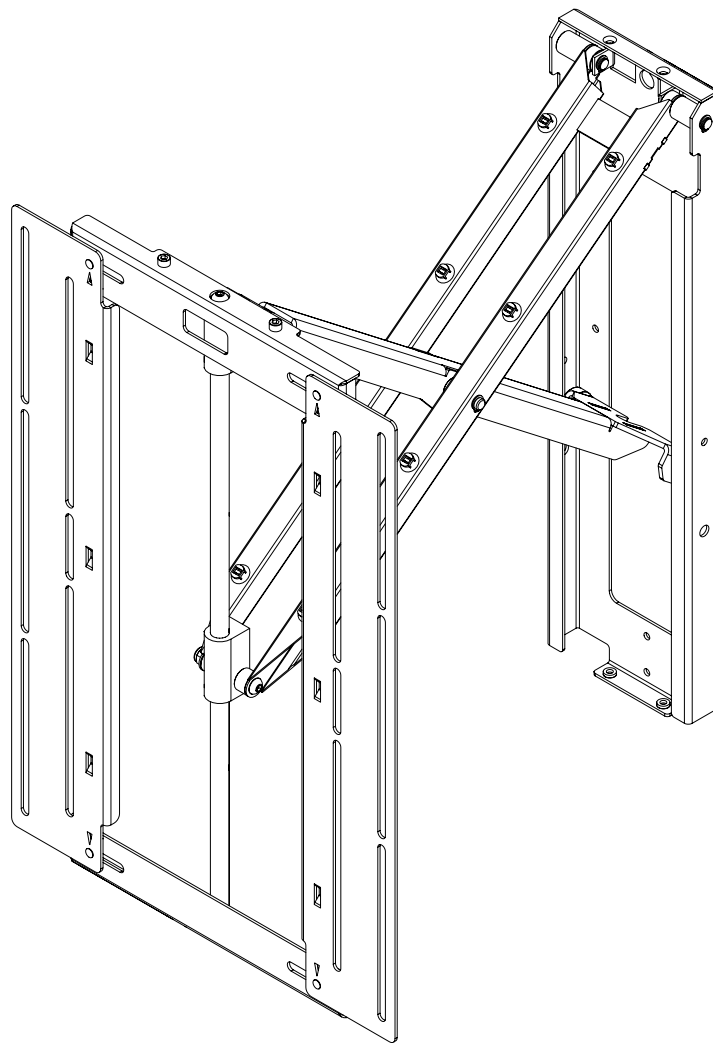

future automation

# PS RANGE

PS32, 40, 55 & 65 MANUAL ARTICULATING WALL MOUNTS



## INSTALLATION INSTRUCTIONS

ISSUE 005



# SAFETY DISCLAIMER

## IMPORTANT SAFETY INSTRUCTIONS BELOW

**WARNING:** Failure to provide adequate structural strengthening, prior to installation can result in serious personal injury or damage to the equipment. It is the installer's responsibility to ensure the structure to which the component is affixed can support four times the weight of the component and any additional apparatus mounted to the component.

**WARNING:** Do not exceed the weight capacity for this product as listed below. This can result in serious personal injury or damage to the equipment. It is the installer's responsibility to ensure that the total combined weight of all attached components does not exceed that of the maximum figure stated.

**WARNING:** Risk of death or serious injury may occur when children climb on audio and/or video equipment or furniture. A remote control or toys placed on the furnishing may encourage a child to climb on the furnishing and as a result the furnishing may tip over on to the child.

**WARNING:** Risk of death or serious injury may occur. Relocating audio and/or video equipment to furniture not specifically designed to support audio and/or video equipment may result in death or serious injury due to the furnishing collapsing or over turning onto a child or adult.



**WARNING – RISK OF INJURY!**



Only for use with equipment weighing **132LBS (60KG) OR LESS.**

Use with heavier projectors/equipment may lead to instability causing tip over or failure resulting in death or serious injury.

Bracket Suitable for Residential and Commercial Use.

### ADDITIONAL WARNINGS:

1. Keep all documentation/instructions after fitting.
2. Read all technical instructions fully before installation and use. It is the installer's responsibility to ensure that all documentation is passed on to the end user and read fully before operation.
3. Do not use near water or outdoors unless the product has been specifically designed to do so.
4. Protect any cables or cords being used near this bracket from being walked on or pinched to prevent damage and risk of injury.
5. Use this product only for its intended purpose as described in the product instructions and only use attachments/accessories specified by the manufacturer.
6. Do not operate the product if it is damaged in any way, liquid has been spilled or objects have fallen into the apparatus, the apparatus has been exposed to rain or moisture, does not operate normally, or has been dropped. Contact the original installer/manufacturer to arrange repair or return.

### WARNING - To reduce the risk of burns, fire, electric shock, or injury to persons:

1. Clean only with a dry cloth and always unplug any electrical items being used in conjunction with this product before cleaning.

Future Sound & Vision trading as Future Automation intend to make this and all documentation as accurate as possible. However, Future Automation makes no claim that the information contained herein covers all details, conditions or variations, nor does it provide for every possible contingency in connection with the installation or use of this product. The information contained in this document is subject to change without prior notice or obligation of any kind. Future Automation makes no representation of warranty, expressed or implied, regarding the information contained herein. Future Automation assumes no responsibility for accuracy, completeness or sufficiency of the information contained in this document.

# PRODUCT WARRANTY & RISK ASSESSMENT

## WARRANTY INFORMATION

**WARNING - The warranty offered for this product shall be annulled if the product is used improperly or in a way that is in breach of our Terms of Service.**

Future Automation provides warranty for the mechanism you purchased for the period of **24 months** from the date of purchase, provided that it isn't used for unintended purposes.

Under the warranty, Future Automation aims to either solve the issue remotely (via telephone or email support) or if the mechanism requires a part, arrange a visit to your premises by a Future Automation approved engineer or send replacement items where appropriate.

Warranty repairs will be carried out as quickly as possible, but subject to parts availability. This warranty period is respectively extended for the period of a repair.

A malfunctioning product must be cleaned and placed into suitable packaging to protect against transit damage before organising delivery to a repair workshop.

All the complaints about defects must be submitted to the vendor/installer that sold this product, rather than directly to the manufacturer.

Any part of your system that needs to be replaced during a warranty repair becomes the property of Future Automation.

### **The warranty does not cover the following:**

- Damages resulting from improper product use or maintenance.
- Repairs carried out by unauthorized persons.
- Natural wear and tear during operation.
- Damages caused by the buyer.
- Accidental damages caused by a customer or damages caused as a result of careless attitude or usage, or damages caused by natural disasters (natural phenomena).
- Any electrical, or other environmental work external to your Future Automation mechanism including power cuts, surges etc.
- Additional items not supplied by Future Automation although they may have been supplied together by the retailer
- Any 3rd party software products controlling your mechanism
- Any transfer of ownership. Warranty is provided only to the initial purchaser.
- Compensation for loss of use of the product, and consequential loss of any kind.

A separate Safety and Servicing Information document is provided with these instructions (additional copies can be found at [www.futureautomation.co.uk/safety](http://www.futureautomation.co.uk/safety)), and this document **MUST** be filled out by the approved Future Automation Dealer who is installing the product. This Warranty Sheet must be held by the end user for the duration of the products life and will be referred to during servicing or warranty queries.

The Safety and Servicing Information document also contains two Service History Forms that must be filled in by the approved Future Automation dealer who is performing the first required yearly service of this product.

**One copy of the Service History Form must be held by the customer (along with the Warranty Sheet) and a duplicate copy must be held by the approved Future Automation dealer that performed the service. Missing and/or mismatching documents may delay or invalidate warranty claims.**

Additional Service History Forms can be found on the Future Automation website for further yearly services.

## RISK ASSESSMENT INFORMATION

It is the installer's responsibility to perform a risk assessment of installed products. Future Automation can provide guidelines to installers/dealer about what should be included in a risk assessment, but due to the individual nuances of each location/site, Future Automation cannot provide a full list of areas to risk assess.

For full risk assessment and safety information please view our Safety and Servicing guide available at [www.futureautomation.net/safety](http://www.futureautomation.net/safety)

# GUIDE CONTENTS

SAFETY DISCLAIMER.....	<b>1</b>
PRODUCT WARRANTY & RISK ASSESSMENT.....	<b>2</b>
GUIDE CONTENTS.....	<b>3</b>
PACKAGE CONTENTS.....	<b>4</b>
VESA MOUNT ADJUSTMENTS.....	<b>5</b>
CALCULATING MOUNTING HEIGHT.....	<b>6</b>
DETACHING THE SCREEN MOUNT.....	<b>7</b>
SURFACE MOUNTING.....	<b>8</b>
STUD RAIL MOUNTING.....	<b>9</b>
CABLE MANAGEMENT.....	<b>10</b>
FITTING THE SCREEN.....	<b>11</b>
FITTING THE SCREEN CONT.....	<b>12</b>
FRICTION ADJUSTMENT.....	<b>13</b>
NOTES:.....	<b>14</b>

# PACKAGE CONTENTS

## 1 - PS RANGE BRACKET

- 1.1 - WALL PLATE
- 1.2 - SCREEN MOUNT
- 1.3 - SCREEN MOUNT UPRIGHTS
- 1.4 - CABLE TIE ANCHORS

## ITEMS NOT SHOWN ON PAGE

PS RANGE ACCESSORY PACK:

- SCREEN FIXINGS PACK  
(MULTI-PACK OF NUTS, BOLTS, SPACERS AND WASHERS)
- PACK OF CABLE TIES

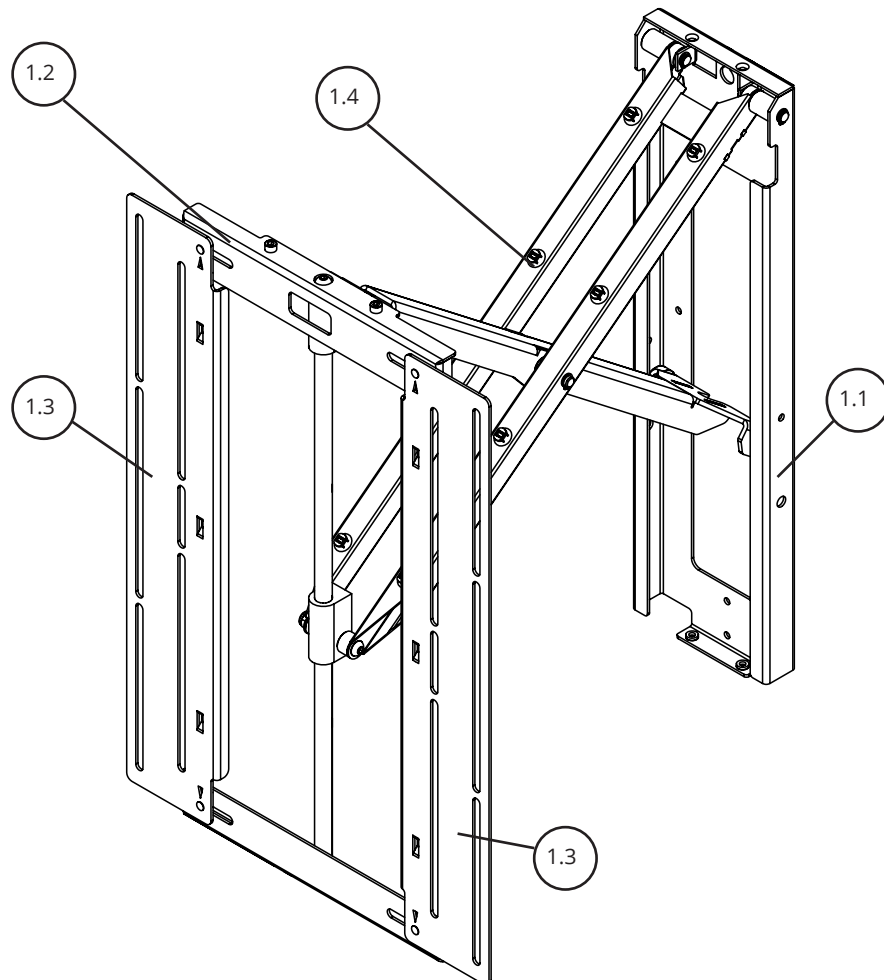

# VESA MOUNT ADJUSTMENTS

## 1

The PS42 and PS50 brackets are capable of mounting all screens with VESA100 to VESA 400 bolt patterns. The bracket will ship with the mount head in VESA 100 / 200 configuration (Lower Left).

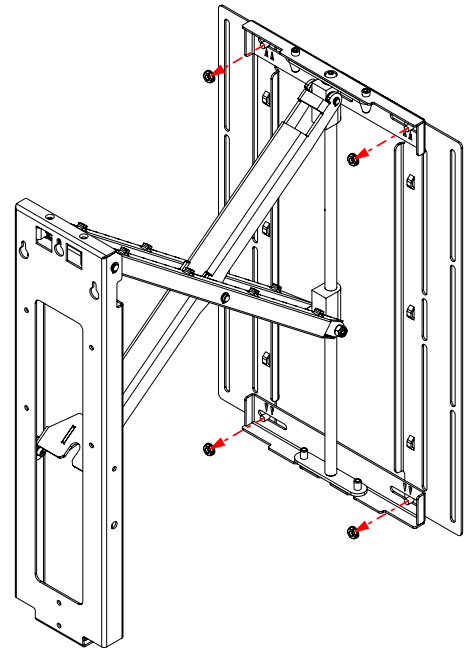

## 2

To achieve VESA 300/ 400 patterns; Release the Screen Mount Uprights by removing the 4 x M8 nuts from rear of the uprights as shown below.

## 3

Switch the left and right uprights over as shown, using arrow indicators to set spacing (inner arrows = VESA 100/ 200 - outer arrows = VESA 300/ 400) and replace the 4 x M8 nuts.

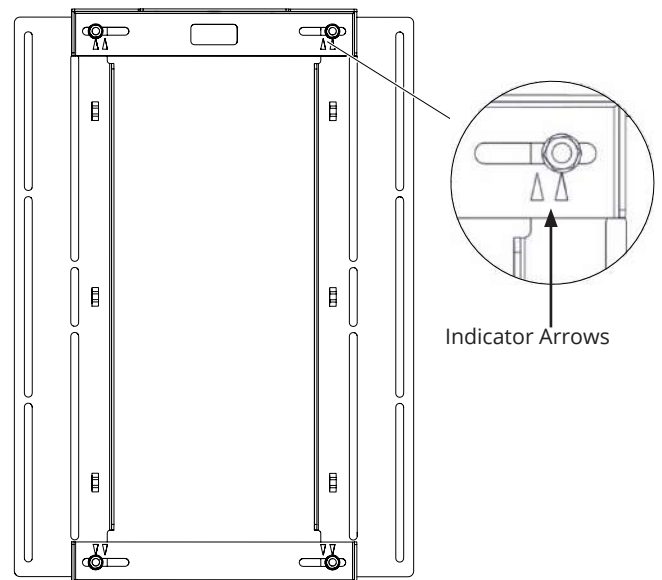

VESA 100/ 200

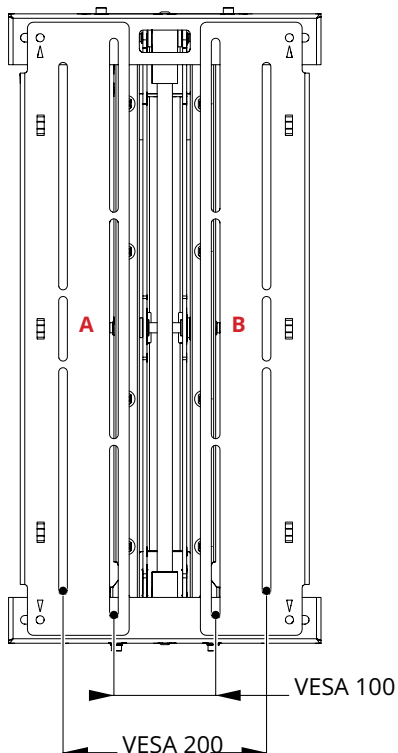

VESA 300/ 400

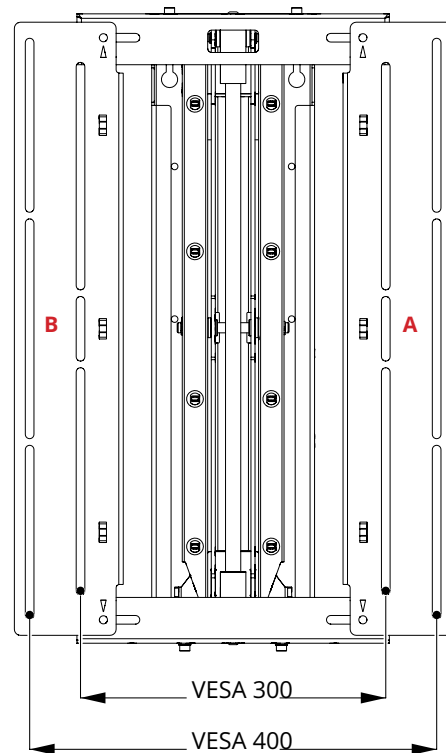

## 5

# CALCULATING MOUNTING HEIGHT

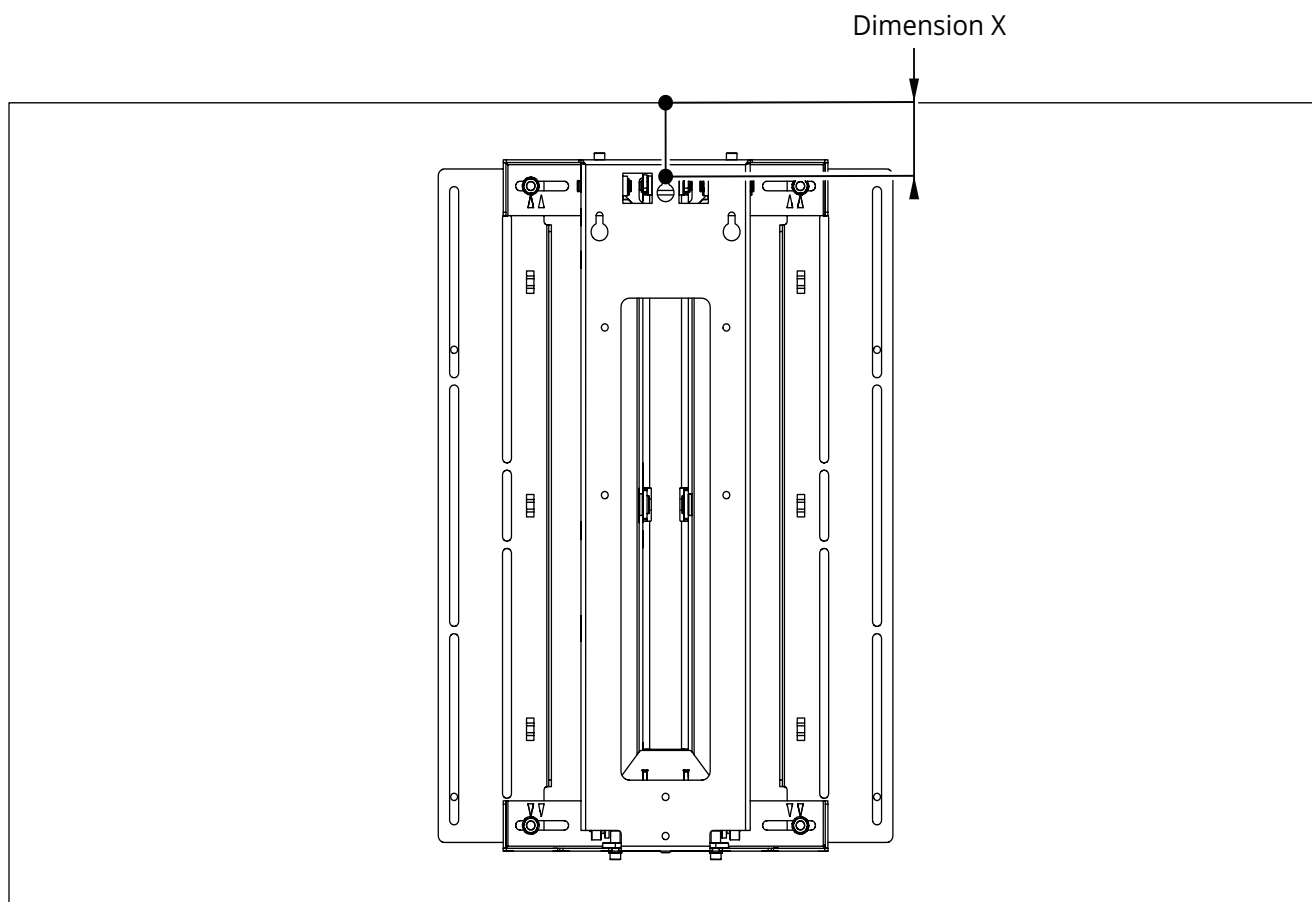

Offer the PS Bracket up to the back of the screen, lining up the screen's VESA holes with the corresponding slots on the PS Bracket Screen Mount. Measure from the top of the screen, down to the top mounting hole on the Wall Plate (Dimension X as indicated above) to determine positioning of the top wall fixing holes.



# DETACHING THE SCREEN MOUNT

## 1

The screen mount will need to be detached from the PS Bracket before wall mounting. This is achieved by removing the 2 x M6 bolts from the underside of frame as shown (Right).

## 2

Once the bolts have been removed, pull the bottom edge of the Mount Frame away from the bracket before lifting it up and away from the Wall Plate.

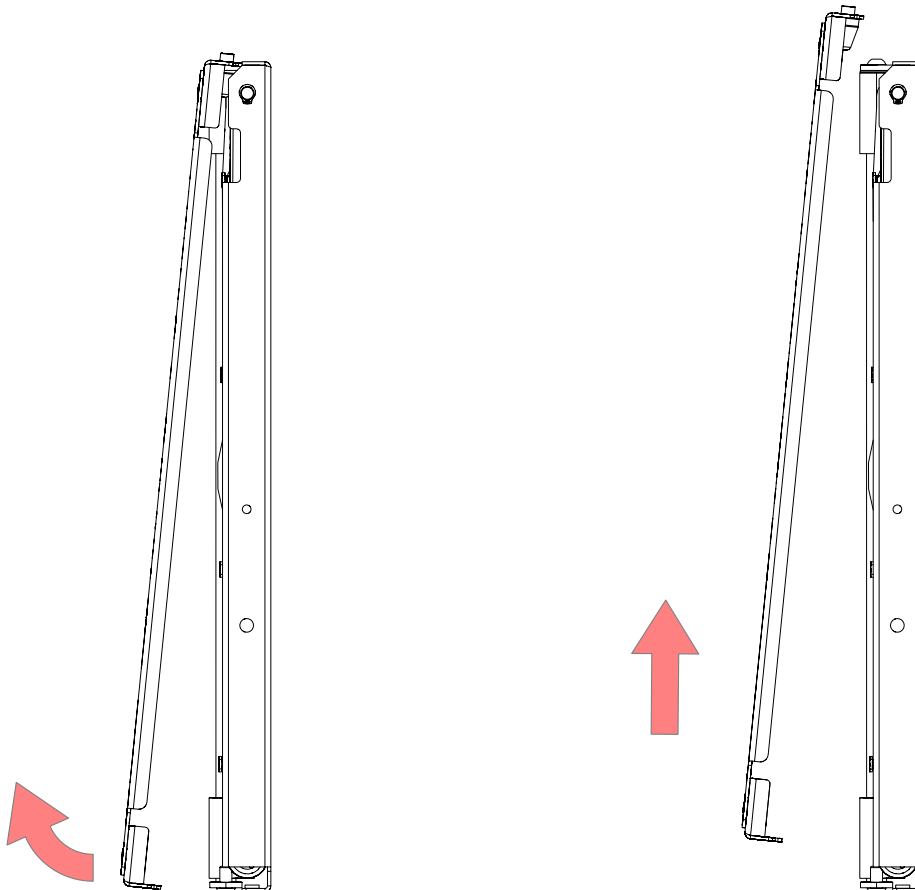
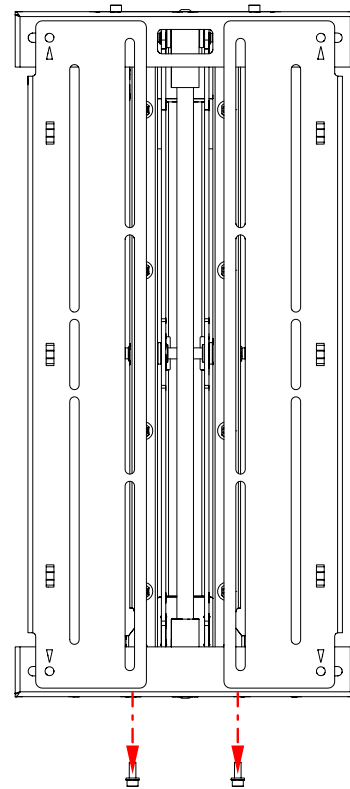

# SURFACE MOUNTING

## 1

The top fixing hole for the PS Bracket wall plate should be located the distance of Dimension X (measured on page 6) down from the top of the screen position. For ease of access, the scissor arms can be pulled out and fixed in place by inserting a screwdriver (or similar) into the side of the wall plate as shown below.

## 2

Fix through the top  $\text{Ø}8.5\text{mm}$  [0.33"] fixing hole in Wall Plate to secure it to the wall. Once checking the bracket is level on the wall, secure the bracket using the remaining 7 fixing holes using suitable fixings (NOT SUPPLIED) as indicated below.

**NOTE:** Maximum fixing bolt head size = 18mm [0.7"]

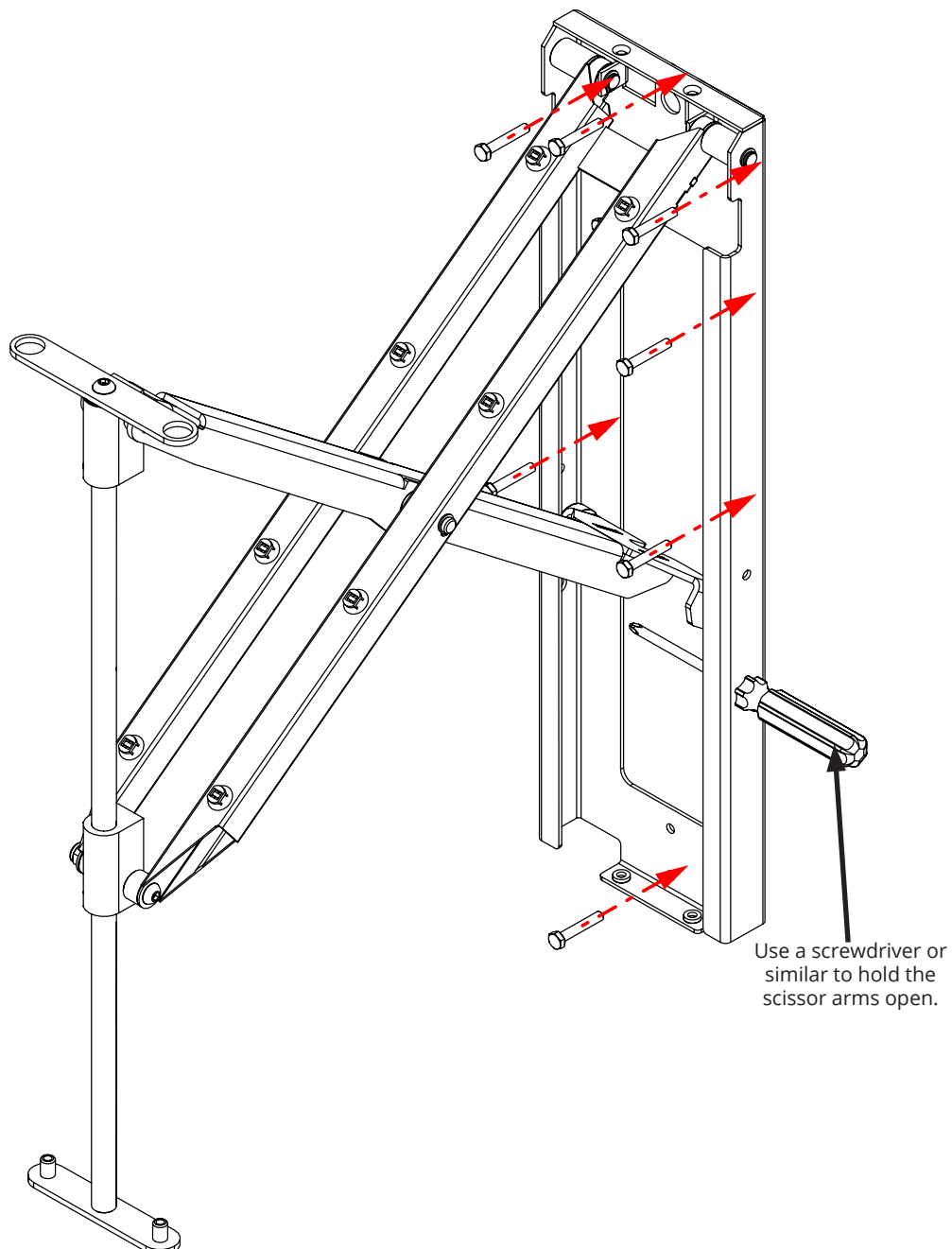

# STUD RAIL MOUNTING

Stud Rail Kit (PS-SRK) sold separately

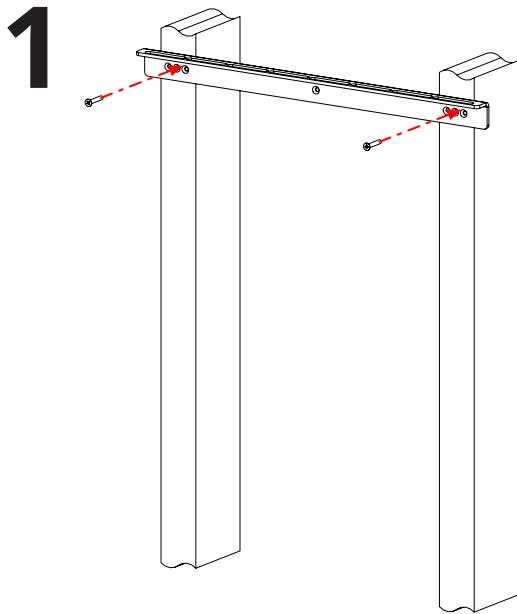

The fixing holes for the upper Stud Rail are located at Dimension X down from the top of the screen position (In-line with top fixing hole on Wall Plate). Use this dimension to position the upper Stud Rail on the wall first. Secure the upper Stud Rail using provided #5 size screws through a single countersunk hole at each end of the rail as shown below.

**NOTE:** Ensure heads of the #5 screws do not sit proud of the Stud Rail front face when fixed in place.

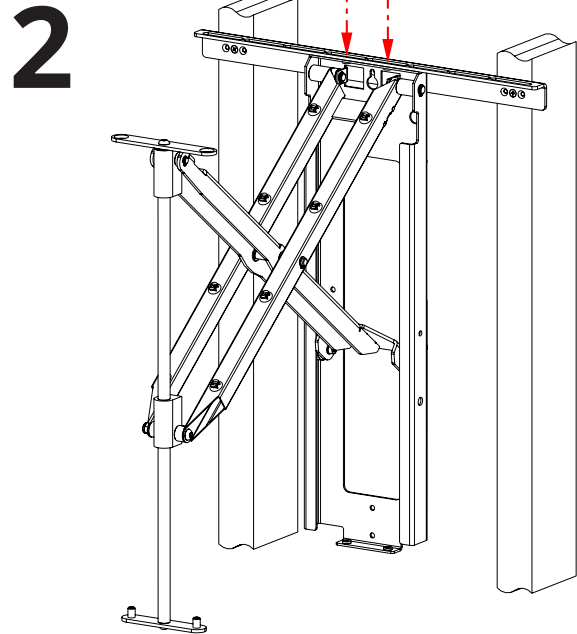

Fix the bracket to the Rail by screwing 2 x M6 bolts through the Rail into threaded holes in the Wall Plate.

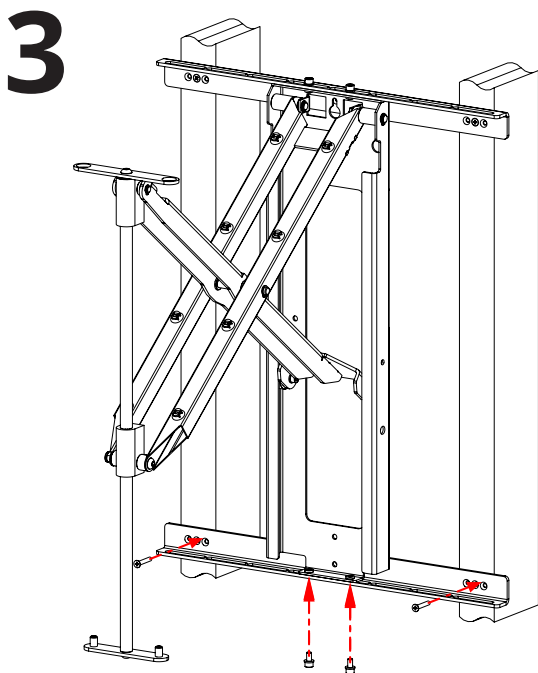

Set the height of the lower Stud Rail by securing it to the bottom of the Wall Plate using 2 x M6 bolts before fixing through countersunk holes into the wall studs.

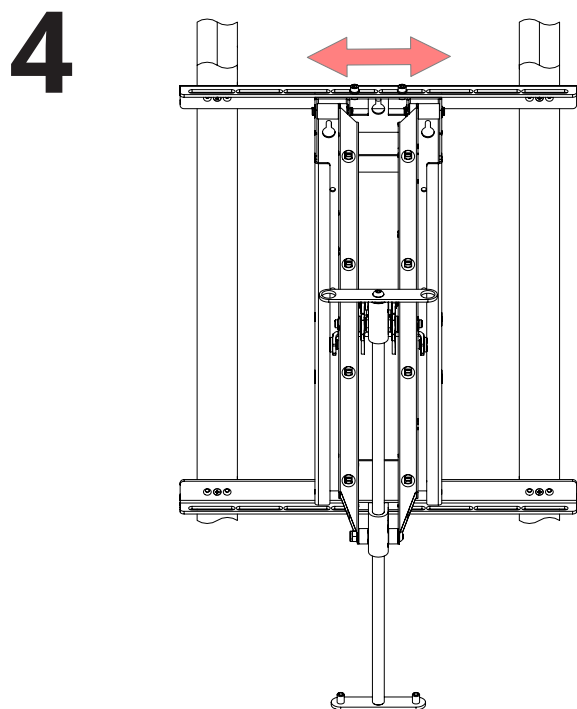

Adjust lateral position by loosening the 2 x M6 bolts enabling the bracket to slide left to right along the rail.

# CABLE MANAGEMENT

**1** Power and signal cable wall sockets should be kept outside of the footprint of the bracket to maximise space available for cable routing - see Tech/ CAD files for bracket dimensions.

**2** All cables should enter the bracket at the top of the Wall Plate, run down each of the outer Scissor Arms and attach to the rear of the Screen Frame as shown below. Use supplied cable ties to secure all cables to the cable anchors on the Scissor Arms and tie bridges on the Screen Uprights.

**3** Ensure sufficient slack is left at the top pivot point of the bracket.

**4** Ensure sufficient slack is left where the cables span between the Scissor Arm and the Screen Frame. Fully advance and rotate the bracket in both directions to ensure cables do not restrict movement.

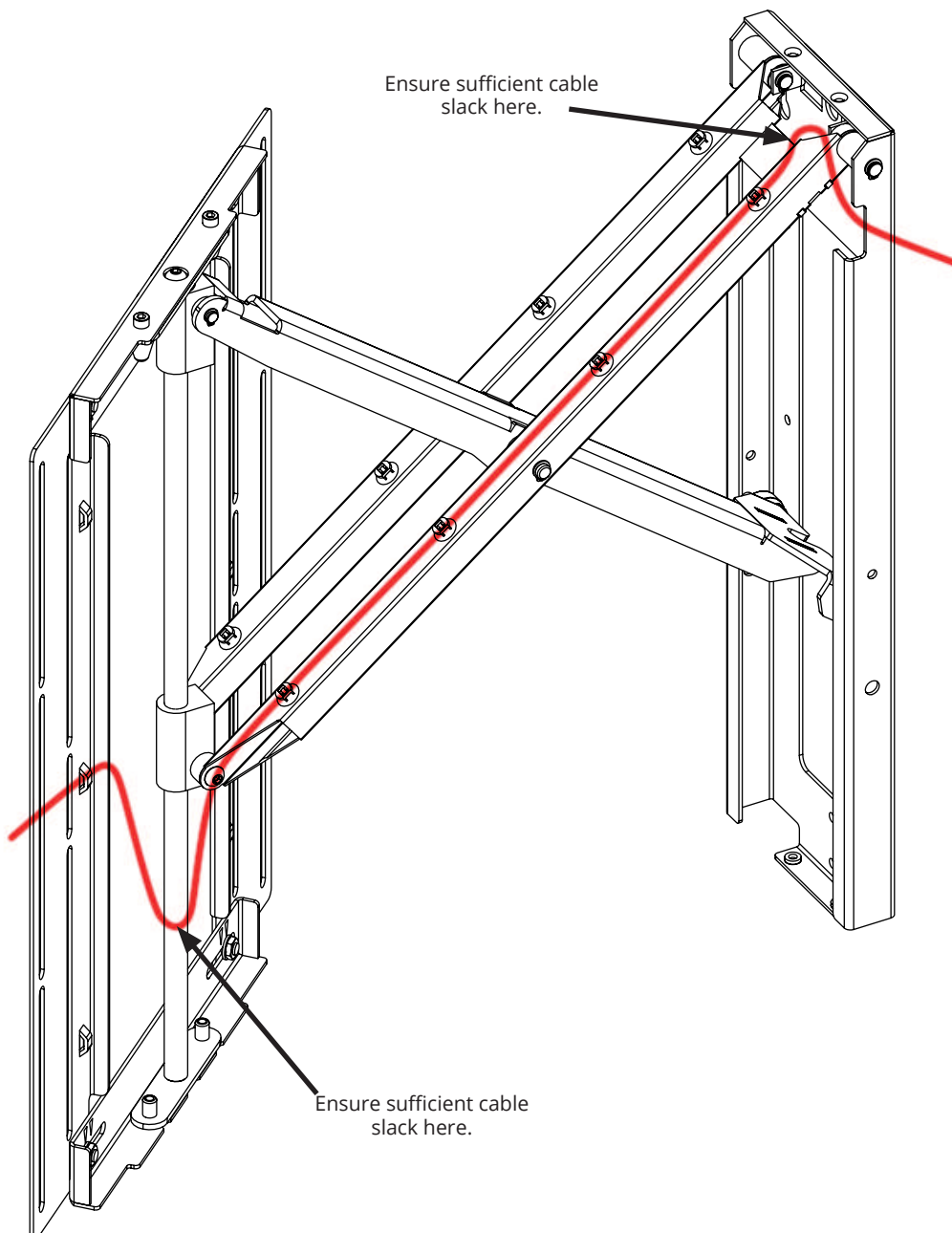

# FITTING THE SCREEN

1

Lay the screen face down on a padded surface and place the Screen Mount, removed in Stage 2, onto the screen's four mount holes. Secure the Screen Mount to the back of the screen, using the bolts and washers provided in the Fixings Pack as shown below. If the screen has recessed mount holes or if you need to space the uprights off for clearance, use the spacers provided in the Fixings Pack.

2

If the screen being installed has a very low set VESA pattern then an optional Vertical Offset Adapter can be used to extend the effective length of the Screen Mount. Simply lay each adapter plate onto the front face of the Screen Mount and secure in place using 4 x M8 nuts provided.

3

If the Uprights need to be re-configured to suit an alternative VESA pattern, see page 5.

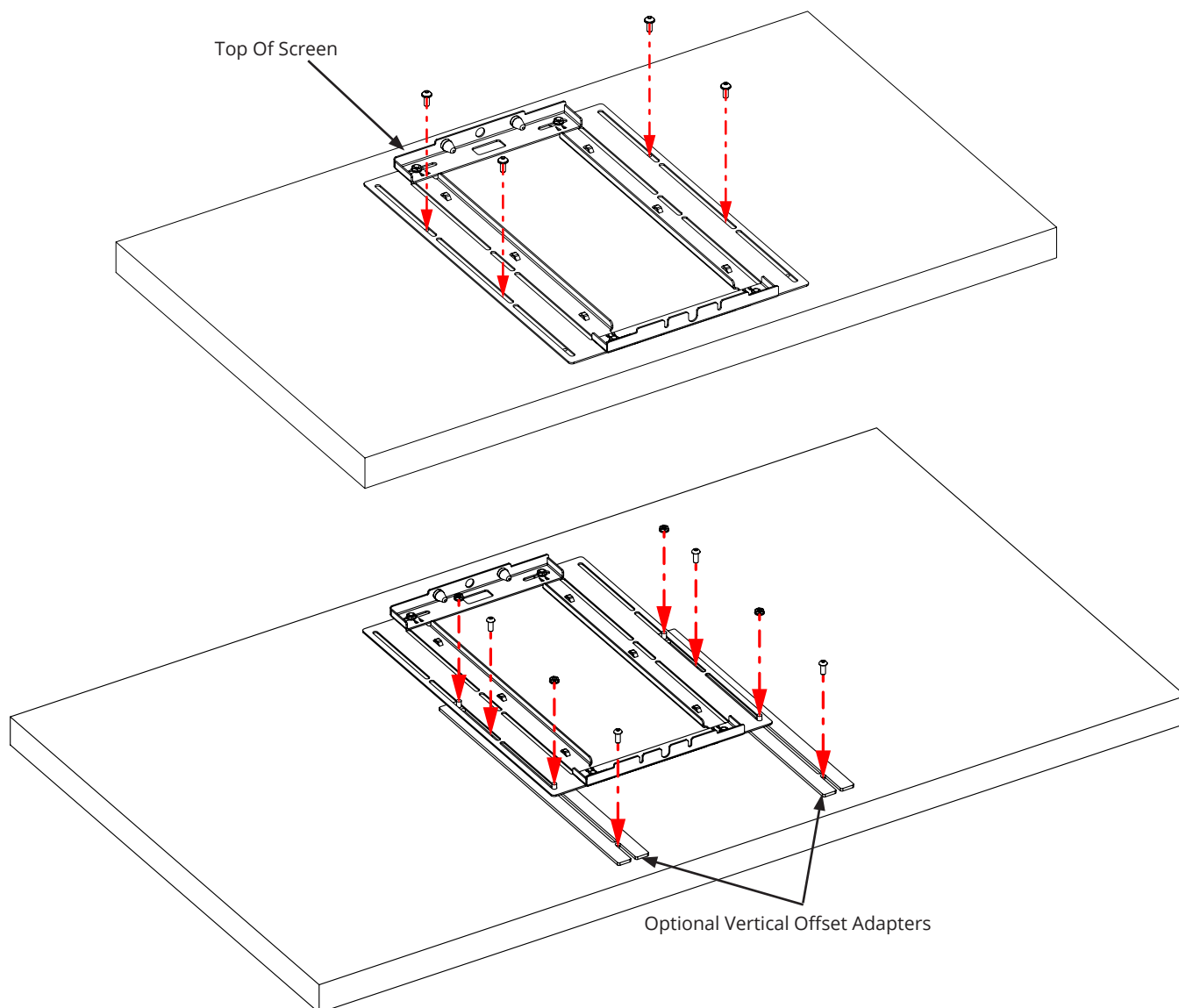

**NOTE:** Screens that do not have standard VESA bolt patterns may require an adapter plate.

# FITTING THE SCREEN CONT.

4

Lift the Screen and Mount Frame up and onto the central bar of the PS Bracket, hooking it on the opposite way to its removal on page 8. Make sure the 2 locating nubbins at the top of the screen mount are securely fixed onto the plate at the top of the bar.

5

Secure the Screen and Mount Frame to the rest of the bracket by replacing the 2 x M6 bolts into the underside of Mount Frame.

6

Connect all power and signal cables to Screen and check that enough slack has been left for the full range of motion of the bracket.

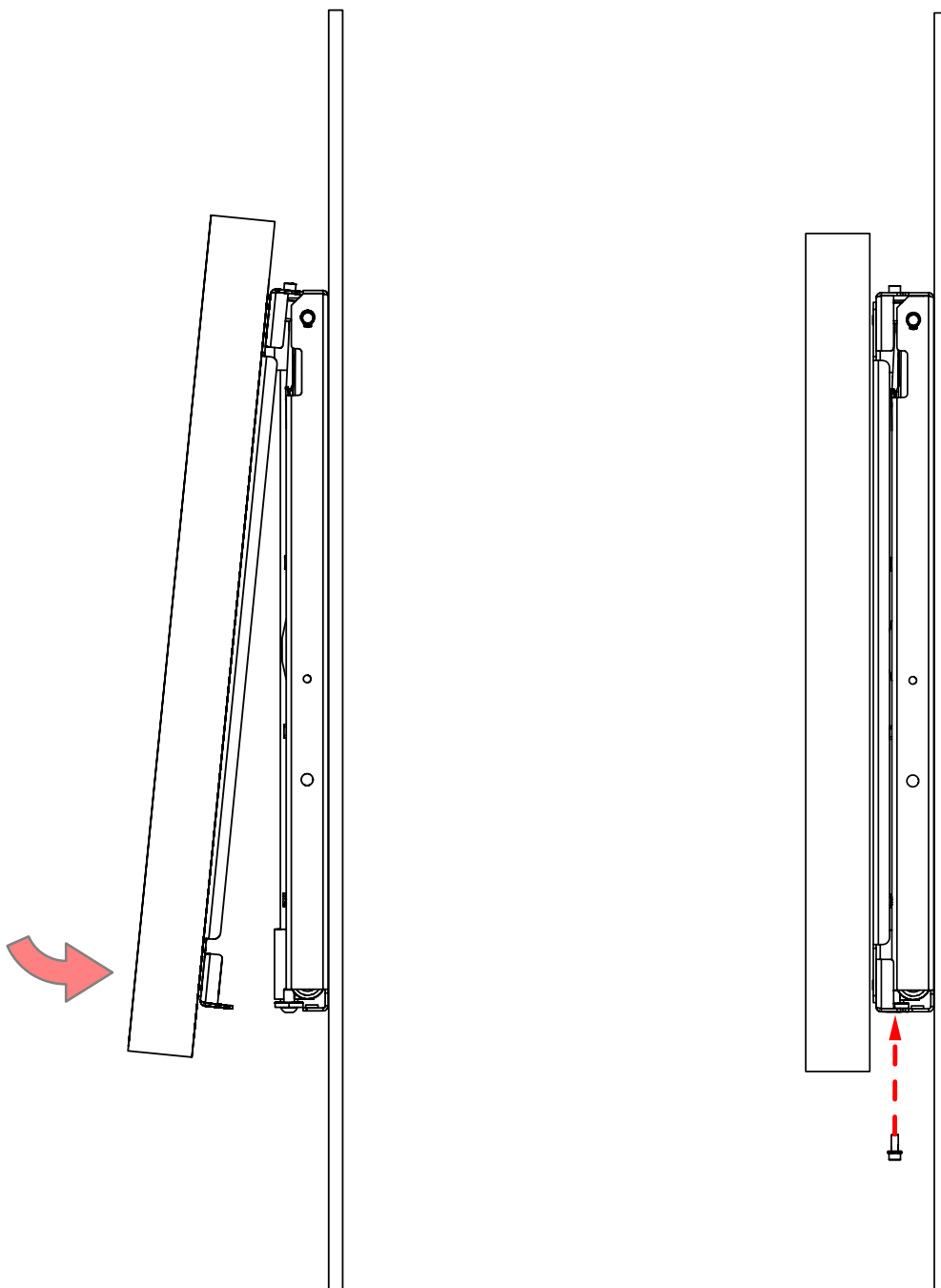

# FRICION ADJUSTMENT

Once fitted, if you find that the PS bracket's pull function is too stiff or too loose, the friction can be adjusted using the M8 nut and bolt arrangement on the bottom sliding collar as shown below. Loosen bolt to decrease friction, or tighten to increase friction.

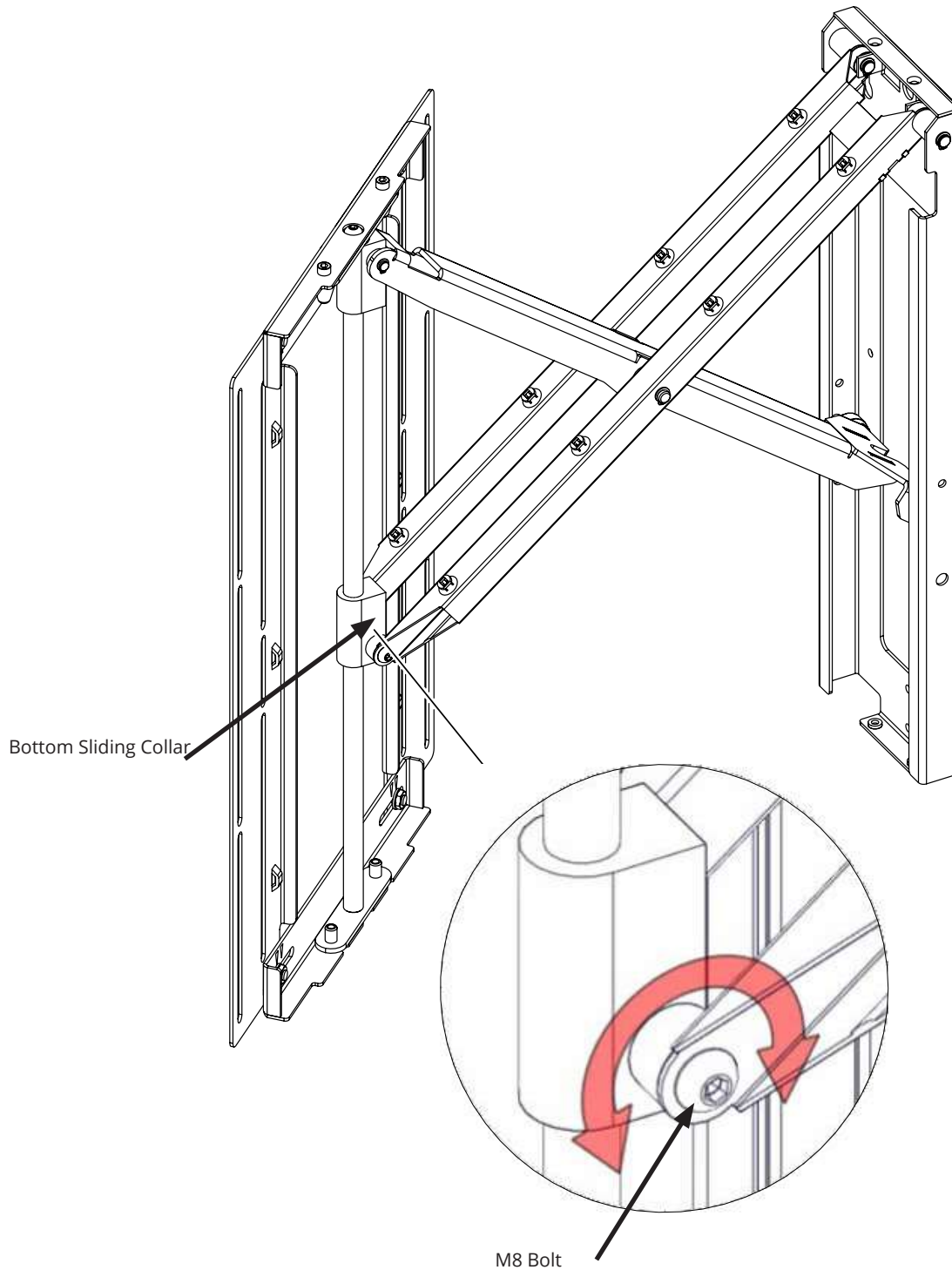



#### **EUROPEAN OFFICE**

**Address:**  
Unit 6-8  
Brunel Road  
Bedford  
Bedfordshire  
MK41 9TG

**Phone:** +44 (0) 1438 833577  
**Email:** [info@futureautomation.co.uk](mailto:info@futureautomation.co.uk)

**Office Hours:**  
Mon - Fri 8:00 to 17:30 GMT  
Saturday & Sunday - Closed

#### **NORTH AMERICAN OFFICE**

**Address:**  
Enterprise Park  
127 Venture Drive  
Dover  
NH  
03820

**Phone:** +1 (603) 742 9181  
**Email:** [info@futureautomation.net](mailto:info@futureautomation.net)

**Office Hours:**  
Mon - Fri 7:00 to 17:00 EST  
Saturday & Sunday - Closed