



DESIGN HIGHLIGHTS

- Drop & Roll concealed flap mechanism creates a tidy appearance
- The rack and pinion system creates a robust and durable lifting mechanism
- Full cable management
- Mechanism can be sized to suit specific screens
- Onboard electronics
- Wide range of mounting options

OPTIONS

- Bang & Olufsen / Loewe mount options

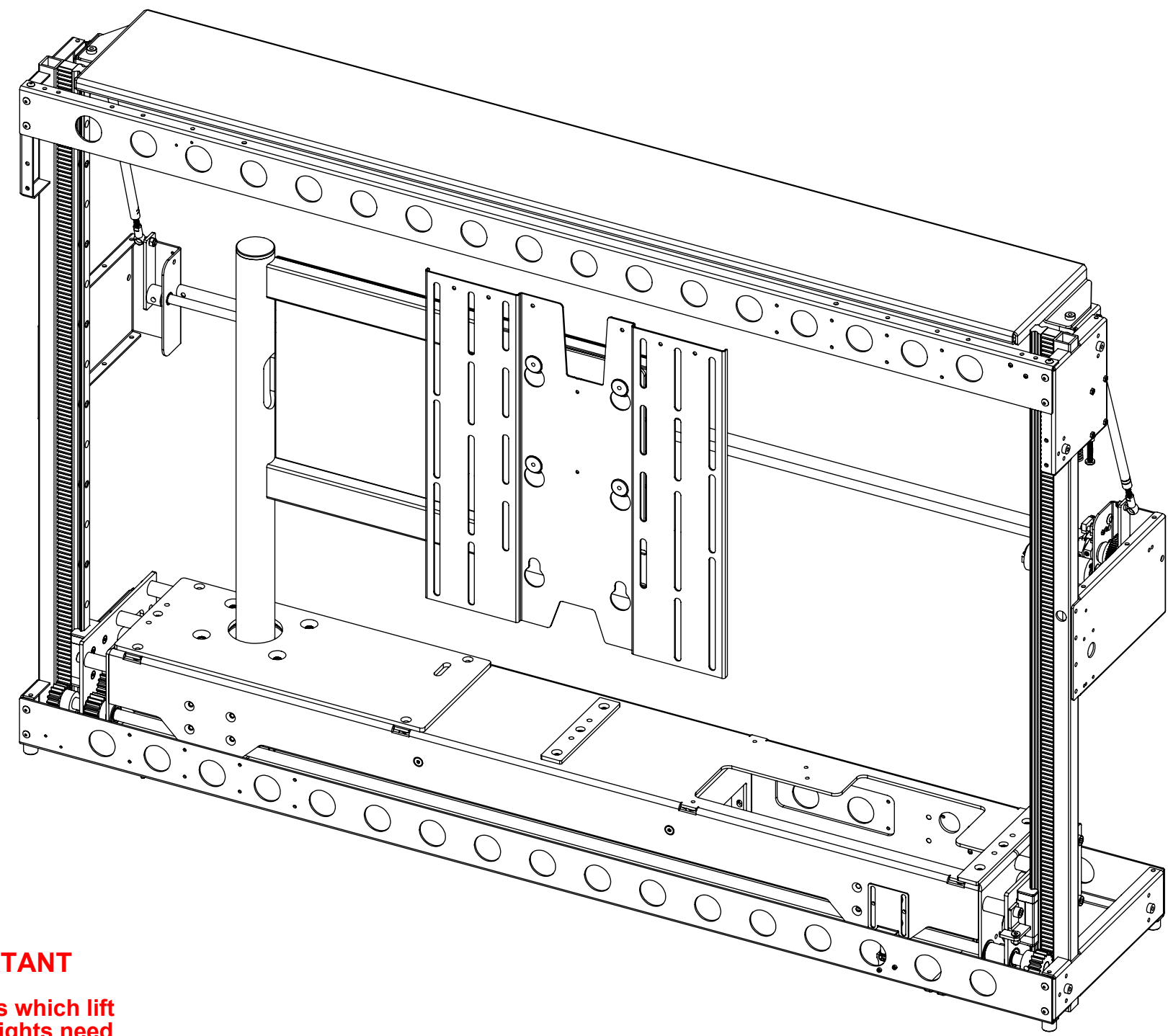

FUNCTION

The electric flap drops down into the cabinet before the screen is raised. The base panel fills the opening when the screen is in the up position.

An optional swivel mount is available, allowing the screen to be watched from multiple viewing angles.

SUITABILITY

The PLH range of lifts is suitable for screen sizes from 32" to 60".

Standard sizes based on 25Kg [55lb] maximum screen weight.

Heavy Duty PLH mechanism is available for larger, heavier screens.

A range of height, width and depth configurations are available to accommodate a broad range of audio / visual products.

SPECIFYING

Specify the Television.

Specify the direction of rotation required.

Establish cabinet dimensions.

Construction of the cabinet can take place whilst the mechanism is being manufactured by Future Automation.

CONTROL

Supplied with basic infrared remote. Can be learnt by many learning remotes.

Also has switch control and RS232 so can be operated by relays, switches, Crestron / AMX or Lutron systems.

WARNING

It is the responsibility of the installer to warn all potential end users of the dangers of interfering with mechanisms during operation

IMPORTANT

Mechanisms which lift or move weights need to be checked on a yearly basis for any damage which may result in an accident



Design Highlights

The PLH is an extremely robust screen lifting solution, making it ideal for applications where extra strength is required.

The electric flap lowers into the cabinet by approximately 40mm [1.5"] before rolling back in the cabinet. The screen is then raised through the aperture in the cabinet top. This method of flap movement gives the neatest possible appearance as there is no flap panel visible when the screen is in the viewing position.

Once fully elevated, the base panel fills the aperture in the cabinet top.

Many size options are available allowing the most efficient cabinet dimensions to be used for the chosen screen.

Full cable management keeps all screen power and signal cables safe and secure during mechanism operation.

Many mounting options are available for Loewe and Bang & Olufsen screens.

An advanced control system allows the lift mechanism to be easily controlled via home automation systems such as Crestron and AMX. Two way communication is also possible via RS232.

Mechanism can be factory configured as left hand (LH) or right hand (RH) hinge point mechanism. This allows the PLH mechanism to be used in almost any corner installation.

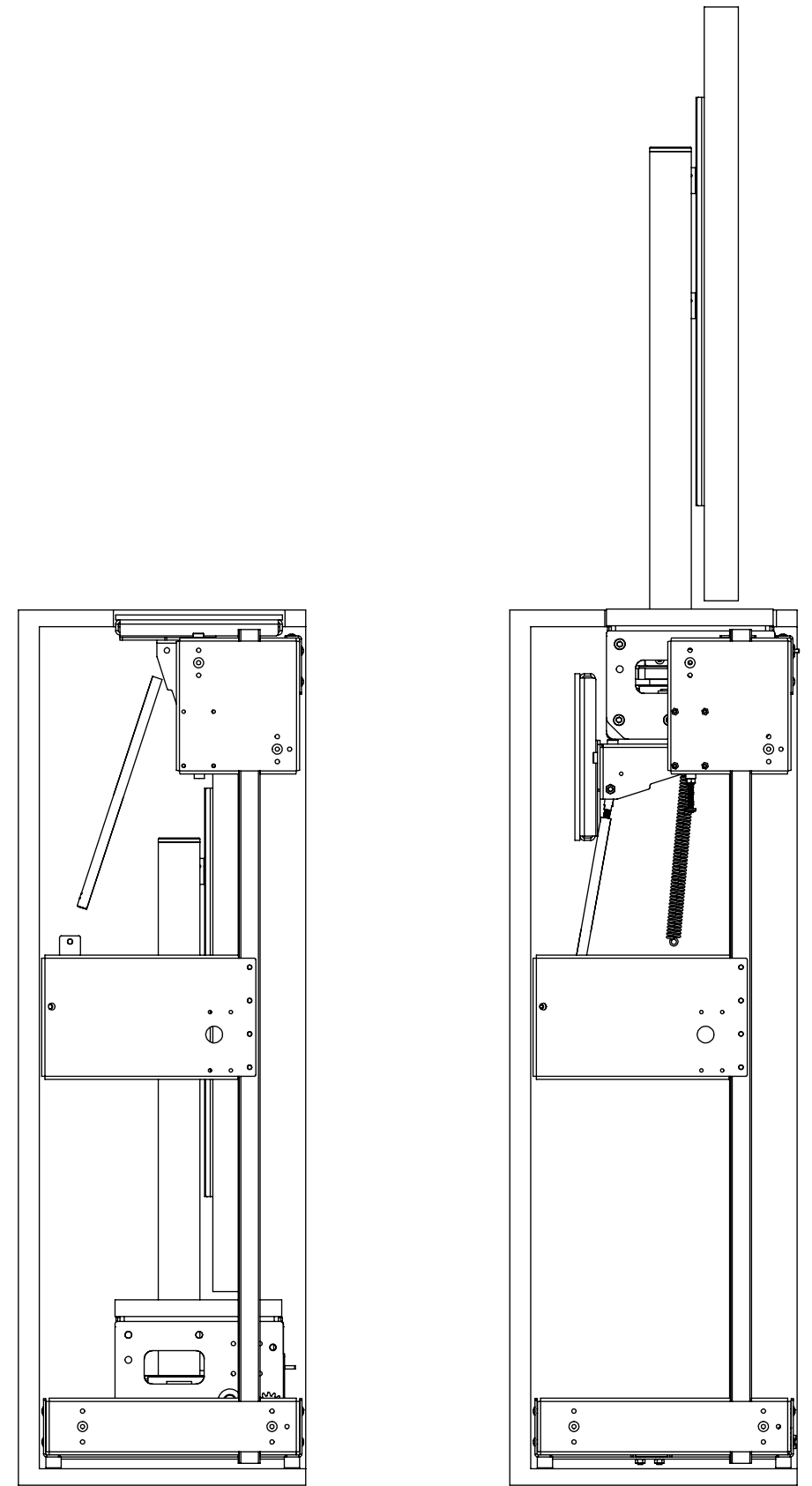
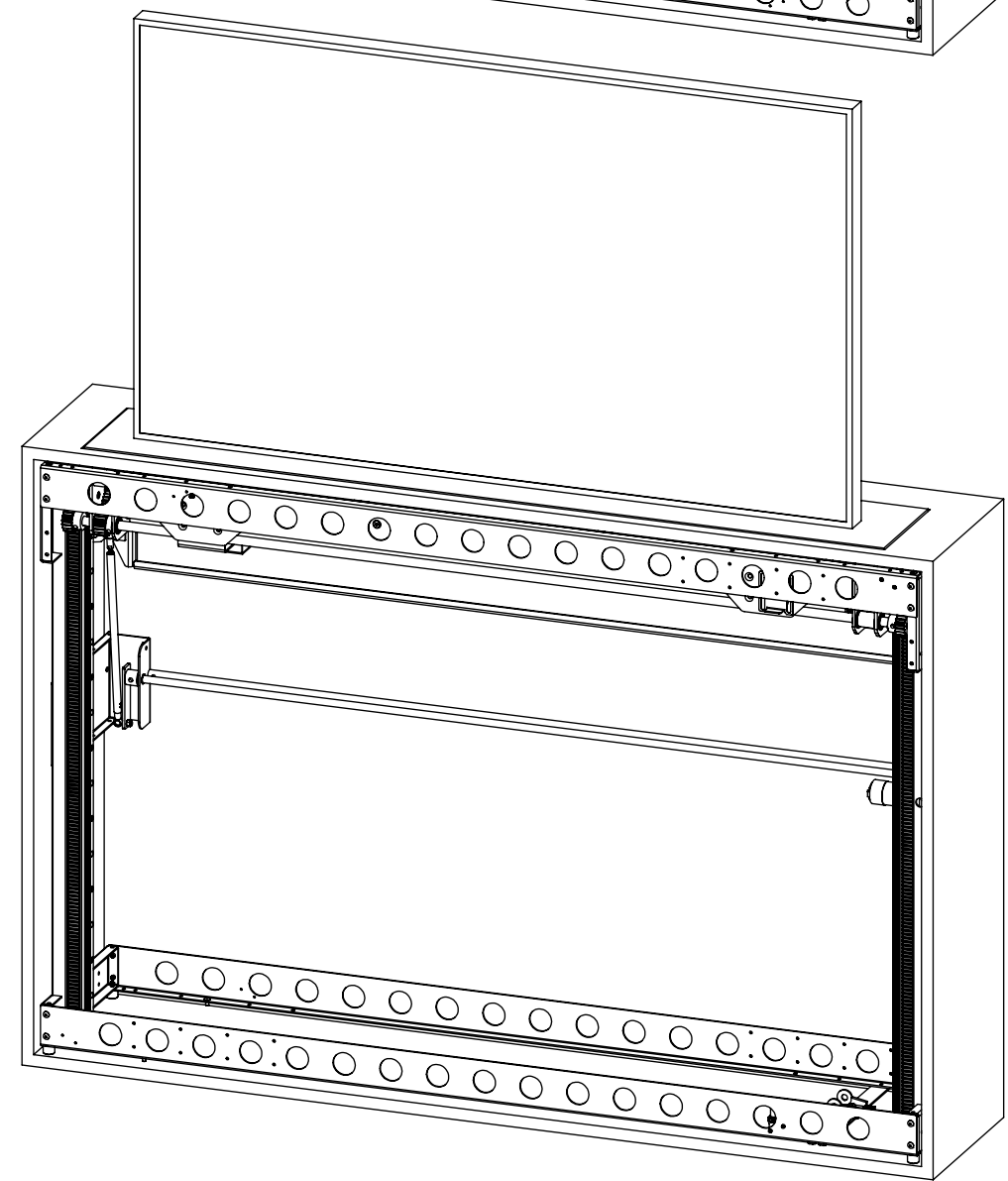
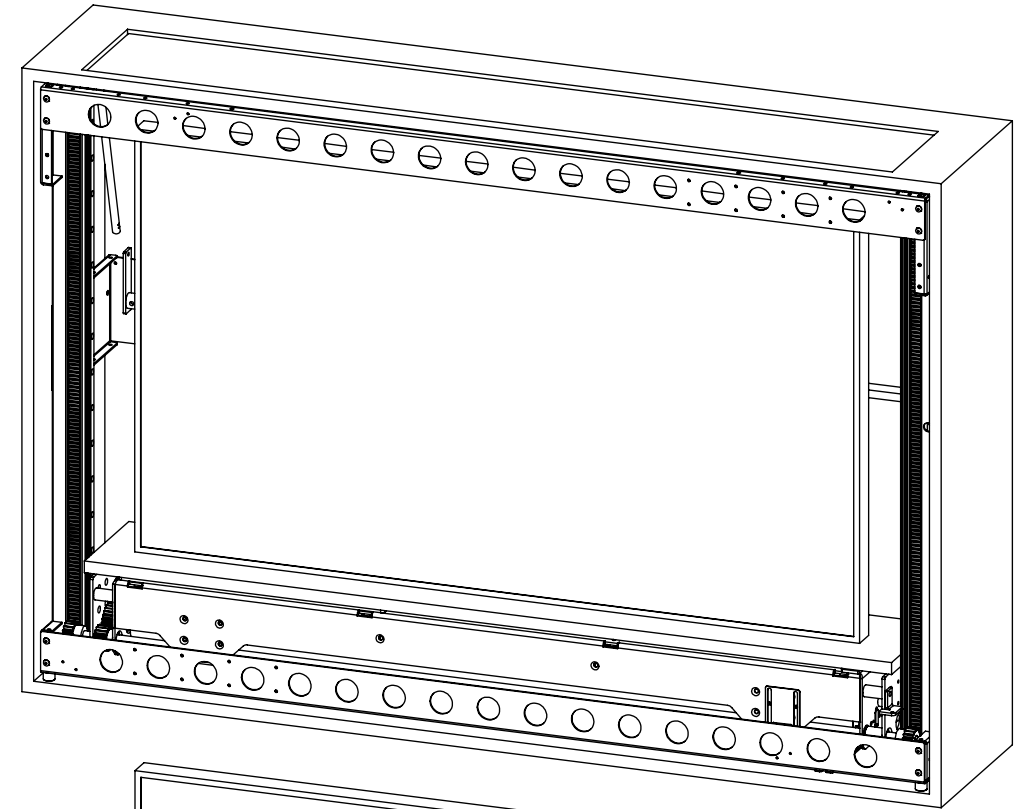

Important Information

Start with screen size. Match the size of your screen to one of the standard lift sizes. Make sure that you don't include the stand, as a suitable support framework will be supplied with the mechanism. Make sure the size includes any clip on speakers required.

The flap is only 6mm thick. This is bonded to an Aluminium section beneath supplied with the lift. This will help prevent warping. It is advisable to varnish both sides of the flap.

The base goes under the screen and will need holes drilled during installation for the support framework and screen cables.

The height and width are critical so make the cabinet to the exact size stated in the technical sheets. The lift mechanism will be slightly smaller than the sizes given. The depth of the cabinet can be increased.

Full front or back access is required in order to insert the mechanism within the cabinet.

For safety reasons it is advisable for the cabinet top to be held on only with dowels. This will allow the top to be lifted off if a hand is placed in the opening when the screen is lifting.

The weight limit is 25Kg [55lb] for the sizes given in this document. For installation of heavier screens a taller mechanism is required.

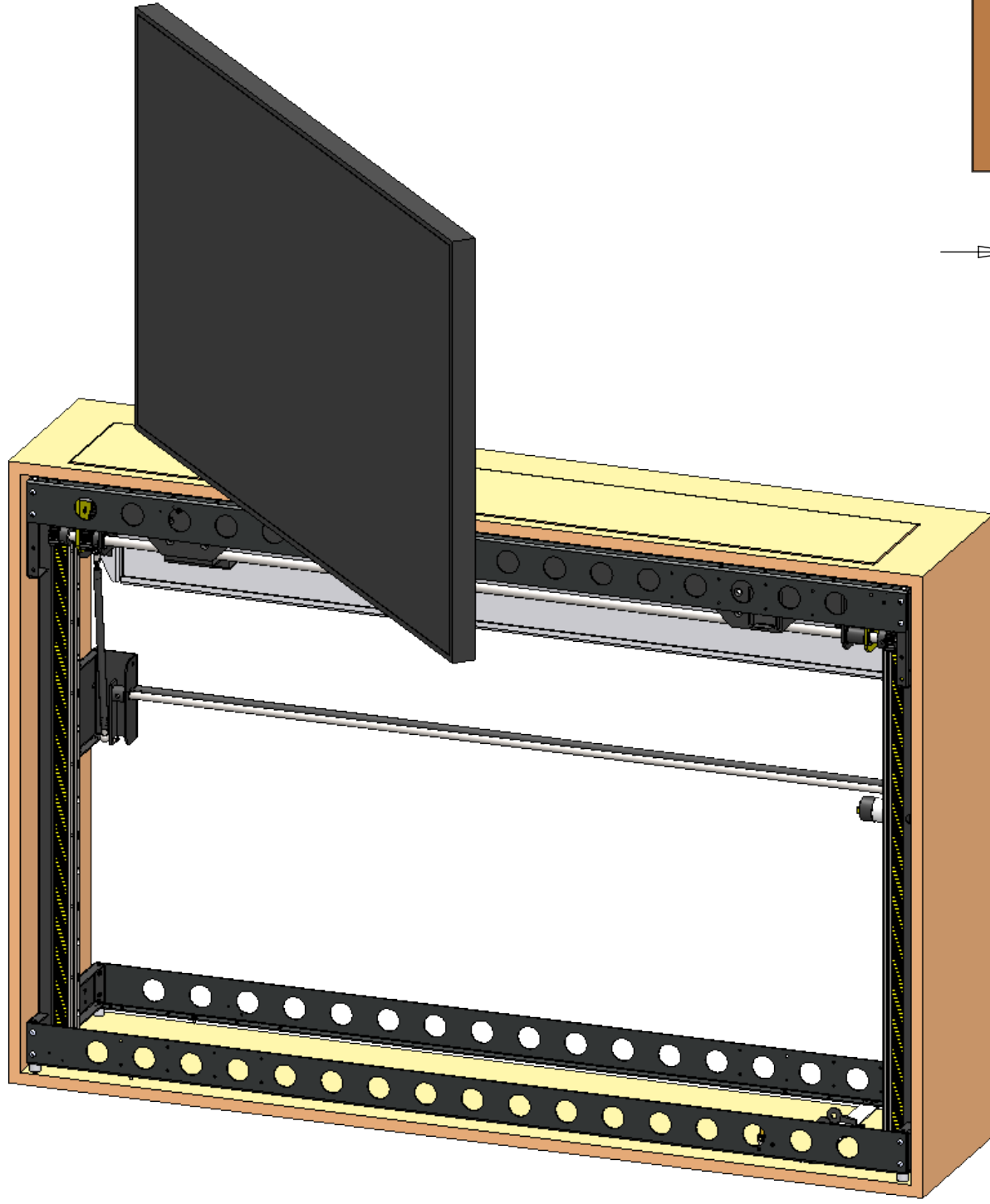

Example of a Thicker Cabinet Top

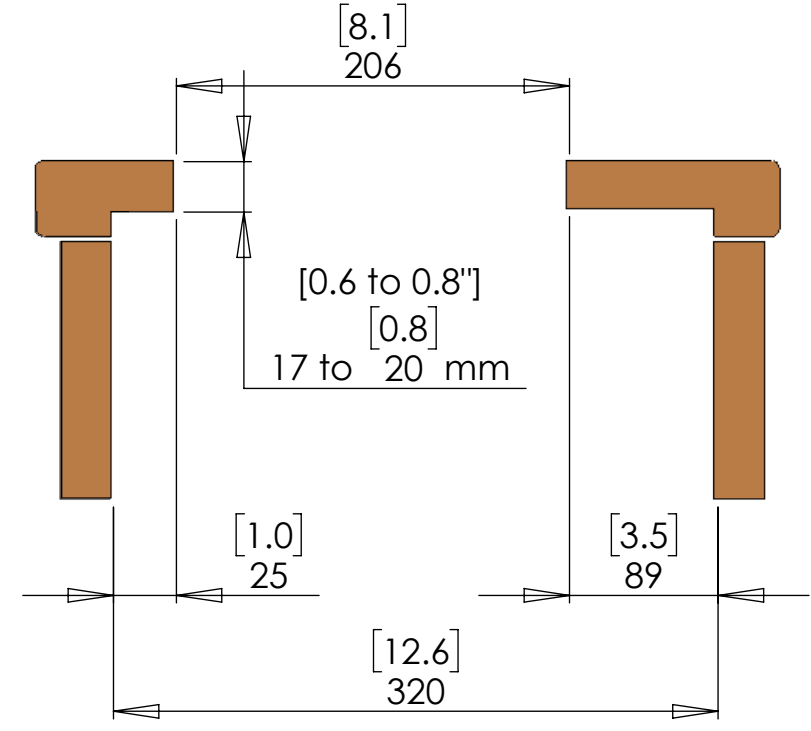

The section above shows the use of a thicker cabinet top. This is possible but the top thickness around the mechanism must be between 17 and 20mm.

Cabinet Dimensions

Maximum screen thickness - 70mm [2.75"]
Maximum screen weight - 25Kg [55lb]

Maximum flap panel weight - 4Kg [9lb]
Maximum base panel weight - 6Kg [13lb]

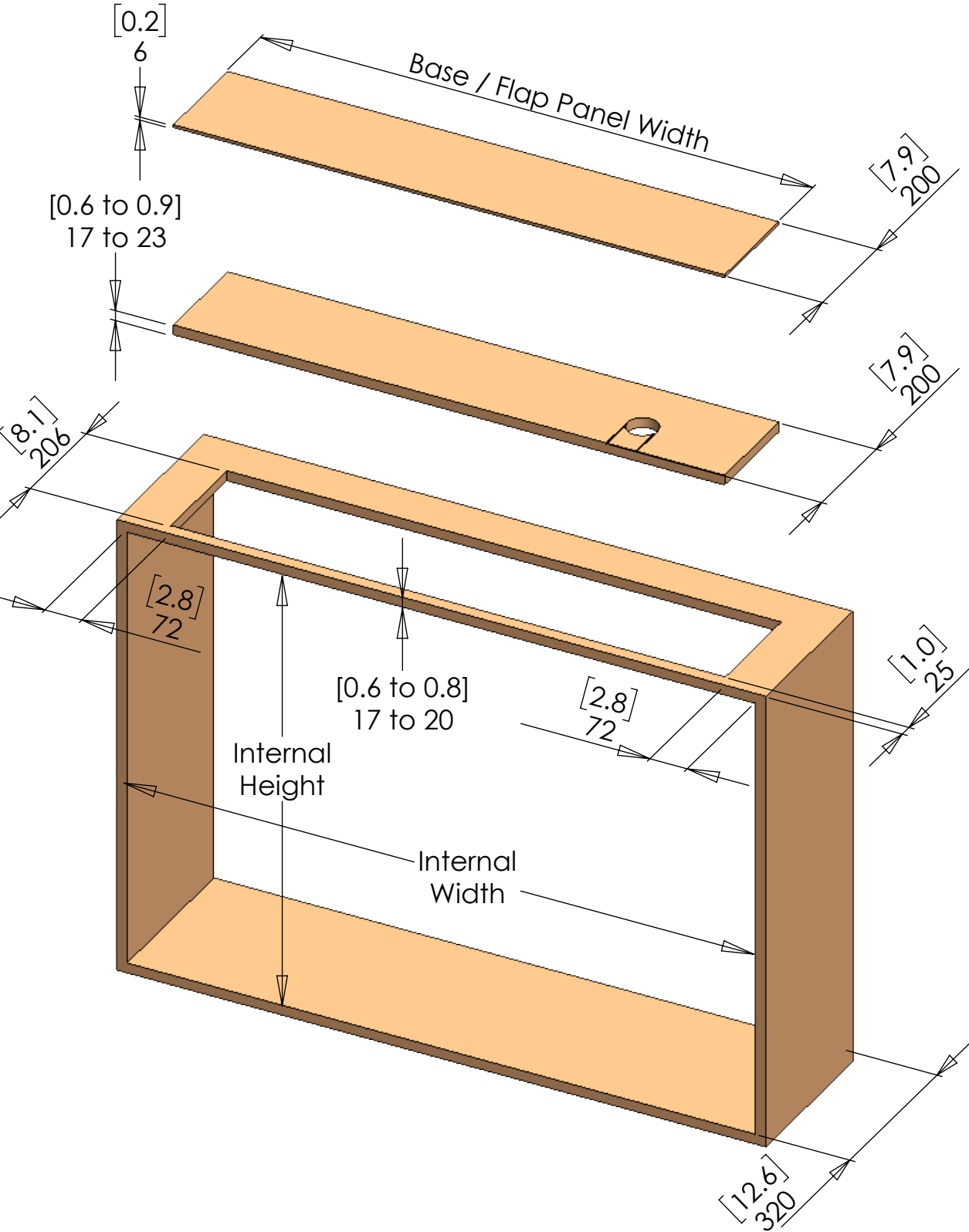

MAXIMUM SCREEN HEIGHT mm [inches]	INTERNAL HEIGHT mm [inches]
585 [23.0]	H 860 [33.9]
635 [25.0]	H 910 [35.8]
685 [27.0]	H 960 [37.8]
735 [28.9]	H 1010 [39.8]
785 [30.9]	H 1060 [41.7]
835 [32.9]	H 1110 [43.7]
885 [34.8]	H 1160 [45.7]

MAXIMUM SCREEN WIDTH - ROTATION <70° mm [inches]	MAXIMUM SCREEN WIDTH - ROTATION <90° mm [inches]	BASE / FLAP PANEL WIDTH mm [inches]	INTERNAL WIDTH mm [inches]
750 [29.5]	700 [27.5]	770 [30.3]	W 920 [36.3]
850 [33.5]	800 [31.5]	870 [34.3]	W 1020 [40.2]
950 [37.4]	900 [35.4]	970 [38.2]	W 1120 [44.1]
1050 [41.3]	1000 [39.3]	1070 [42.1]	W 1220 [48.1]
1150 [45.3]	1100 [43.3]	1170 [46.1]	W 1320 [52.0]
1250 [49.2]	1200 [47.2]	1270 [50.0]	W 1420 [56.0]
1350 [53.1]	1300 [51.1]	1370 [53.9]	W 1520 [59.9]
1450 [57.1]	1400 [55.1]	1470 [57.9]	W 1620 [63.8]

Hinge Mechanism

The PLH mechanism allows a screen to be rotated up to 90 about its end.

Left Handed and Right Handed versions are available

Up to four user defined angular positions can be stored in the mechanism memory via the IR remote control.

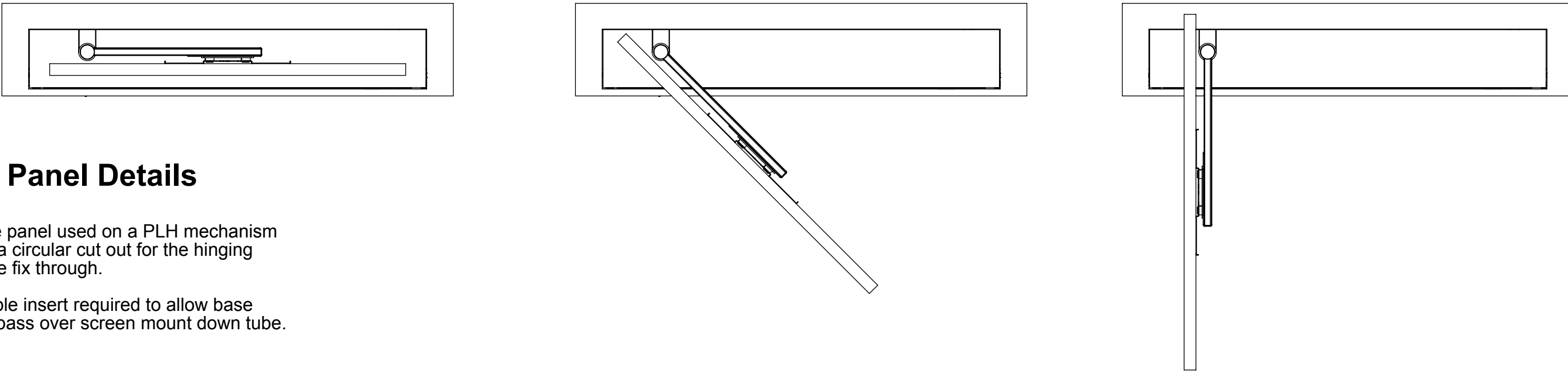

Base Panel Details

The base panel used on a PLH mechanism requires a circular cut out for the hinging mount the fix through.

Removable insert required to allow base panel to pass over screen mount down tube.

