

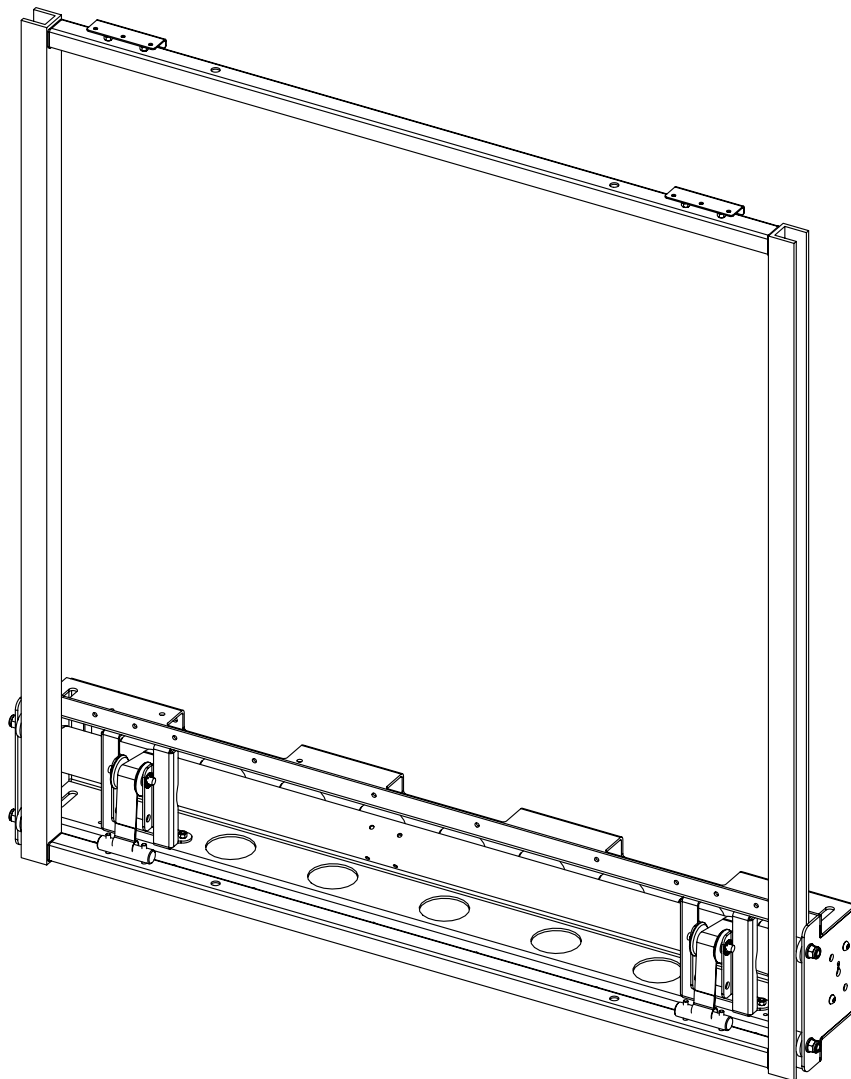

future automation

PIC-H

PIC-H1, PIC-H2, PIC-H3
HEAVY PICTURE LIFTING MECHANISM



INSTALLATION INSTRUCTIONS

ISSUE 014

SAFETY DISCLAIMER

IMPORTANT SAFETY INSTRUCTIONS BELOW

WARNING: Failure to provide adequate structural strengthening, prior to installation can result in serious personal injury or damage to the equipment. It is the installer's responsibility to ensure the structure to which the component is affixed can support four times the weight of the component and any additional apparatus mounted to the component.

WARNING: Do not exceed the weight capacity for this product as listed below. This can result in serious personal injury or damage to the equipment. It is the installer's responsibility to ensure that the total combined weight of all attached components does not exceed that of the maximum figure stated.

WARNING: Risk of death or serious injury may occur when children climb on audio and/or video equipment or furniture. A remote control or toys placed on the furnishing may encourage a child to climb on the furnishing and as a result the furnishing may tip over on to the child.

WARNING: Risk of death or serious injury may occur. Relocating audio and/or video equipment to furniture not specifically designed to support audio and/or video equipment may result in death or serious injury due to the furnishing collapsing or over turning onto a child or adult.



WARNING - RISK OF INJURY!



Only for use with equipment weighing **35KG (77LB) OR LESS.**

Use with heavier equipment may lead to instability causing tip over or failure resulting in death or serious injury.

Mechanism suitable for Residential and Commercial Use.

ADDITIONAL WARNINGS:

1. Keep all documentation/instructions after fitting.
2. Read all technical instructions fully before installation and use. It is the installer's responsibility to ensure that all documentation is passed on to the end user and read fully before operation.
3. Do not use near water or outdoors unless the product has been specifically designed to do so.
4. Protect any cables or cords being used near this bracket from being walked on or pinched to prevent damage and risk of injury.
5. Use this product only for its intended purpose as described in the product instructions and only use attachments/accessories specified by the manufacturer.
6. Do not operate the product if it is damaged in any way, liquid has been spilled or objects have fallen into the apparatus, the apparatus has been exposed to rain or moisture, does not operate normally, or has been dropped. Contact the original installer/manufacturer to arrange repair or return.

WARNING - To reduce the risk of burns, fire, electric shock, or injury to persons:

1. Clean only with a dry cloth and always unplug any electrical items being used in conjunction with this product before cleaning.

Future Sound & Vision trading as Future Automation intend to make this and all documentation as accurate as possible. However, Future Automation makes no claim that the information contained herein covers all details, conditions or variations, nor does it provide for every possible contingency in connection with the installation or use of this product. The information contained in this document is subject to change without prior notice or obligation of any kind. Future Automation makes no representation of warranty, expressed or implied, regarding the information contained herein. Future Automation assumes no responsibility for accuracy, completeness or sufficiency of the information contained in this document.

PRODUCT WARRANTY & RISK ASSESSMENT

WARRANTY INFORMATION

WARNING - The warranty offered for this product shall be annulled if the product is used improperly or in a way that is in breach of our Terms of Service.

Future Automation provides warranty for the mechanism you purchased for the period of **24 months** from the date of purchase, provided that it isn't used for unintended purposes.

Under the warranty, Future Automation aims to either solve the issue remotely (via telephone or email support) or if the mechanism requires a part, arrange a visit to your premises by a Future Automation approved engineer or send replacement items where appropriate.

Warranty repairs will be carried out as quickly as possible, but subject to parts availability. This warranty period is respectively extended for the period of a repair.

A malfunctioning product must be cleaned and placed into suitable packaging to protect against transit damage before organising delivery to a repair workshop.

All the complaints about defects must be submitted to the vendor/installer that sold this product, rather than directly to the manufacturer.

Any part of your system that needs to be replaced during a warranty repair becomes the property of Future Automation.

The warranty does not cover the following:

- Damages resulting from improper product use or maintenance.
- Repairs carried out by unauthorized persons.
- Natural wear and tear during operation.
- Damages caused by the buyer.
- Accidental damages caused by a customer or damages caused as a result of careless attitude or usage, or damages caused by natural disasters (natural phenomena).
- Any electrical, or other environmental work external to your Future Automation mechanism including power cuts, surges etc.
- Additional items not supplied by Future Automation although they may have been supplied together by the retailer
- Any 3rd party software products controlling your mechanism
- Any transfer of ownership. Warranty is provided only to the initial purchaser.
- Compensation for loss of use of the product, and consequential loss of any kind.

A separate Safety and Servicing Information document is provided with these instructions (additional copies can be found at www.futureautomation.co.uk/safety), and this document **MUST** be filled out by the approved Future Automation Dealer who is installing the product. This Warranty Sheet must be held by the end user for the duration of the products life and will be referred to during servicing or warranty queries.

The Safety and Servicing Information document also contains two Service History Forms that must be filled in by the approved Future Automation dealer who is performing the first required yearly service of this product.

One copy of the Service History Form must be held by the customer (along with the Warranty Sheet) and a duplicate copy must be held by the approved Future Automation dealer that performed the service. Missing and/or mismatching documents may delay or invalidate warranty claims.

Additional Service History Forms can be found on the Future Automation website for further yearly services.

RISK ASSESSMENT INFORMATION

It is the installer's responsibility to perform a risk assessment of installed products. Future Automation can provide guidelines to installers/dealer about what should be included in a risk assessment, but due to the individual nuances of each location/site, Future Automation cannot provide a full list of areas to risk assess.

For full risk assessment and safety information please view our Safety and Servicing guide available at www.futureautomation.net/safety

GUIDE CONTENTS

SAFETY DISCLAIMER	1
PRODUCT WARRANTY & RISK ASSESSMENT	2
GUIDE CONTENTS	3
PACKAGE CONTENTS	4
MECHANISM QUICK-START GUIDE	5
MECHANISM MOUNTING	6
MECHANISM ASSEMBLY	7
MECHANISM ASSEMBLY CONT.	8
STOP POSITION ADJUSTMENT	9
PICTURE MOUNTING	10
PICTURE MOUNTING CONT.	11
FINAL CHECKS	12
GENERAL CONTROL	13
INFRARED (IR)	14
RADIO FREQUENCY (RF)	15
CONTACT CLOSURE	16
RS232 CONTROL	17

PACKAGE CONTENTS

1 - PIC-H1 PIC-H2 PIC-H3 MECHANISM

- 1.1 - FRAME CROSS MEMBER TOP
- 1.2 - FRAME CROSS MEMBER BOTTOM
- 1.3 - UPRIGHTS
- 1.4 - MAIN CASSETTE
- 1.5 - PANEL MOUNT PLATES

2 - CONTROL BOX

3 - IR REMOTE CONTROL

ITEMS NOT SHOWN ON PAGE

PICH ACCESSORY PACK:

- 2X AAA BATTERIES
- MULTI-PACK OF NUTS
- MAINS POWER, IR AND CONTACT CLOSURE LEADS
- NUTS & BOLTS FIXING PACK
 - QTY. 4X - M8 X 16MM CAP HEAD BOLTS
 - QTY. 4X - M8 FULL NUTS

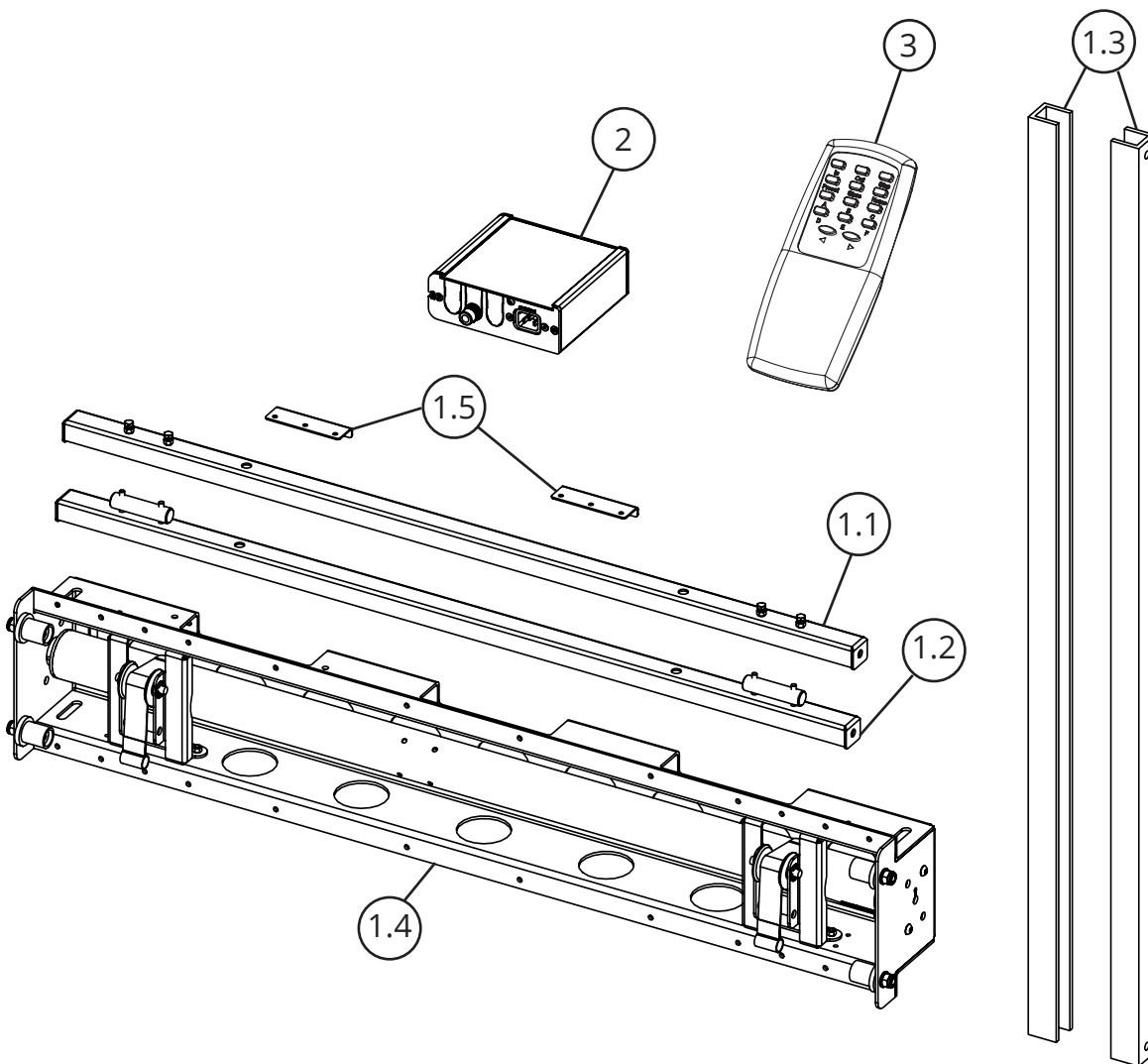

MECHANISM QUICK-START GUIDE

Some Future Automation mechanisms may ship with the control box disconnected to prevent damage during transit. In order to operate the mechanism, the control box will need to be reconnected, then have mains power applied along with the desired control method.

RECONNECTING THE CONTROL BOX

To reconnect the mechanism control box, follow the below steps:

1. Make sure the power is disconnected from the control box.
2. Remove the retaining screw and washer from the end of the control box to allow removal of the control box lid. (Image 1 Below).
3. Slide off the control box lid to reveal the control board inside.
4. Locate the green connector on the end of the loom leading from the lift mechanism. This plug will have a small tag attached stating the correct connecting socket on the control board (e.g. "AC1", "DC2"...). (Image 2 Below).
5. Plug the green connector into the corresponding socket on the control board. This plug is handed and will only connect correctly one way. Do NOT force the connector into the socket, this can cause serious damage to the control board and mechanism.
6. Route the wiring loom out of the end of the control box by inserting the black plastic inserts into the slots provided. (Image 3 Below).
7. Slide the control box cover back over the control board and replace the fixing screw and washer.



Image 1.

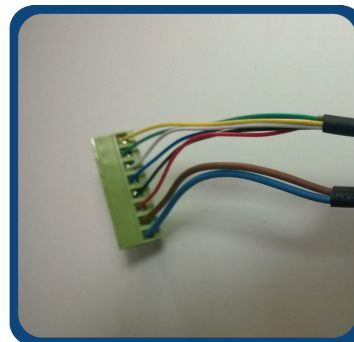

Image 2.



Image 3.



Image 4.

IMPORTANT

For the mechanism to operate, the green three way safety connector with the loop of wire attached, must also be plugged into the end of the control box. (Image 4 above). If this connector is not plugged in, a bright red LED will be visible inside control board and the Input Confirmation Input LED will be permanently illuminated.

MECHANISM MOUNTING

Before installing your mechanism, it is important that you perform the following checks.

- The product is in good condition
- There is no damage to any parts of the mechanism
- All wiring is secure

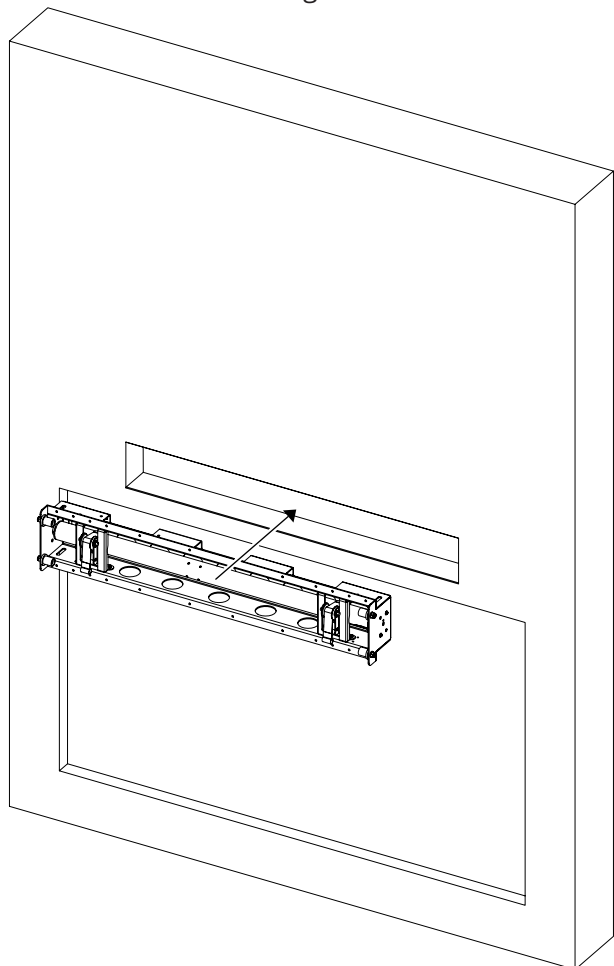

1

Before installation, double check that the wall recess matches the specified height and width that can be found on the corresponding model technical sheet.

2

Insert the mechanism into the recess in the wall, maintaining a symmetrical alignment about the recess whilst keeping the mechanism level as well.

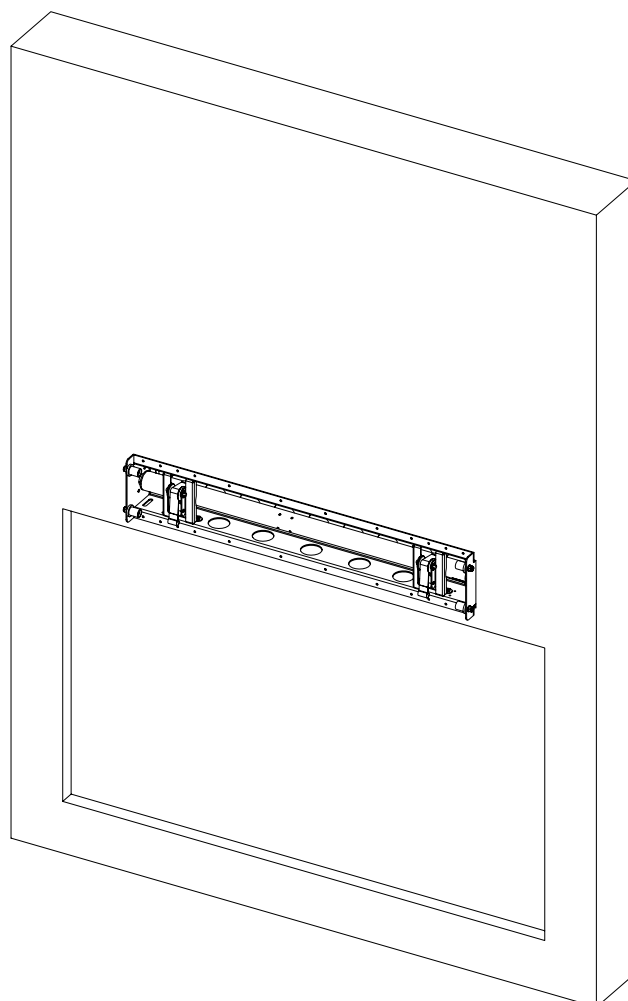

3

With the mechanism in place, fix through the top and bottom front edge of the mechanism using appropriate fixings.
(Fixings NOT included)

MECHANISM ASSEMBLY



CONTROL BOX SETUP

- The control box must be installed in an easy to access location.
- Refer to page 12 for control box wiring instructions.
- Connect the control box to the mains power supply.
- Connect the infrared remote sensor even if you are planning on utilising an alternative control method.
- Ensure cables can be easily extended.
- Access to the control box will be required for servicing and there is no manual drop function.

1

Attach the Uprights to the Frame Cross Member Top using 2 x M8 x 20 Cap Head screws and 2 x M8 nuts provided.

2

Lower the frame onto the cassette ensuring the black plastic are within the uprights.

The Frames fixings will ensure it will stay on the mechanism for the time being.

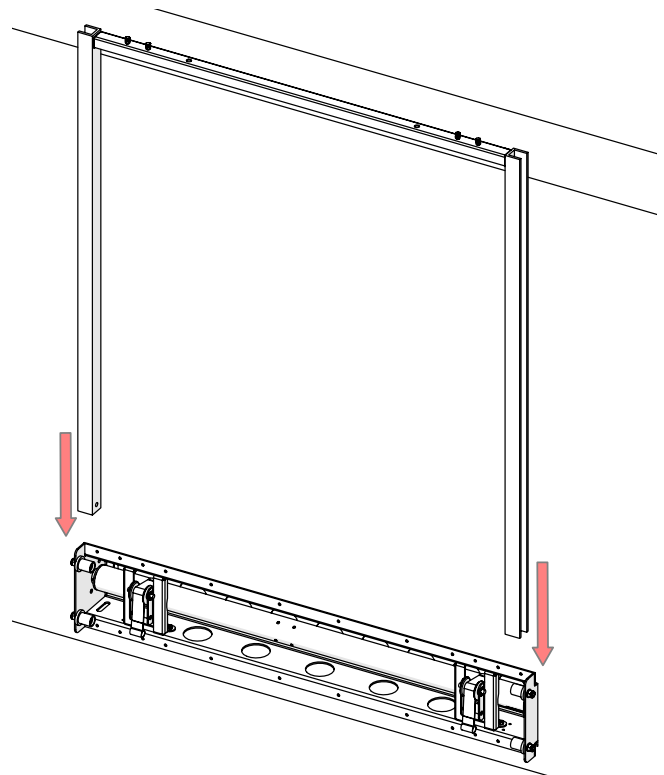
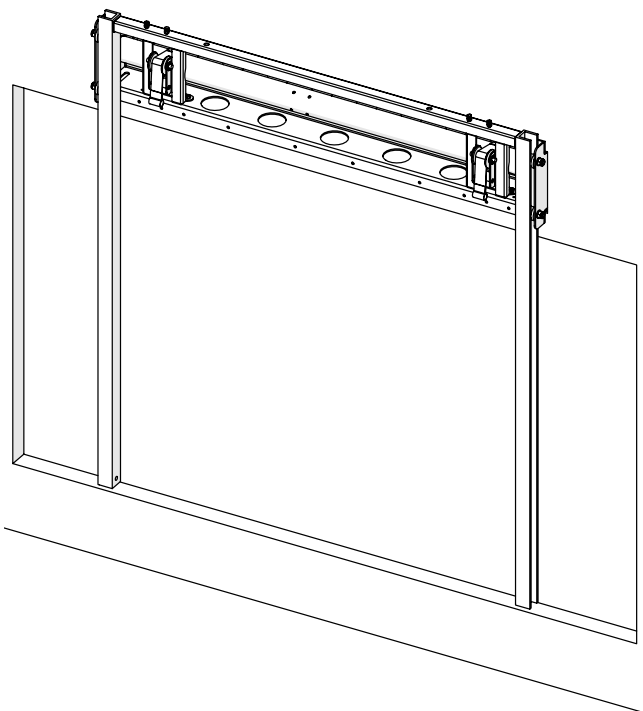

MECHANISM ASSEMBLY CONT.

3

Remove one screw from each Strap Bar as shown.

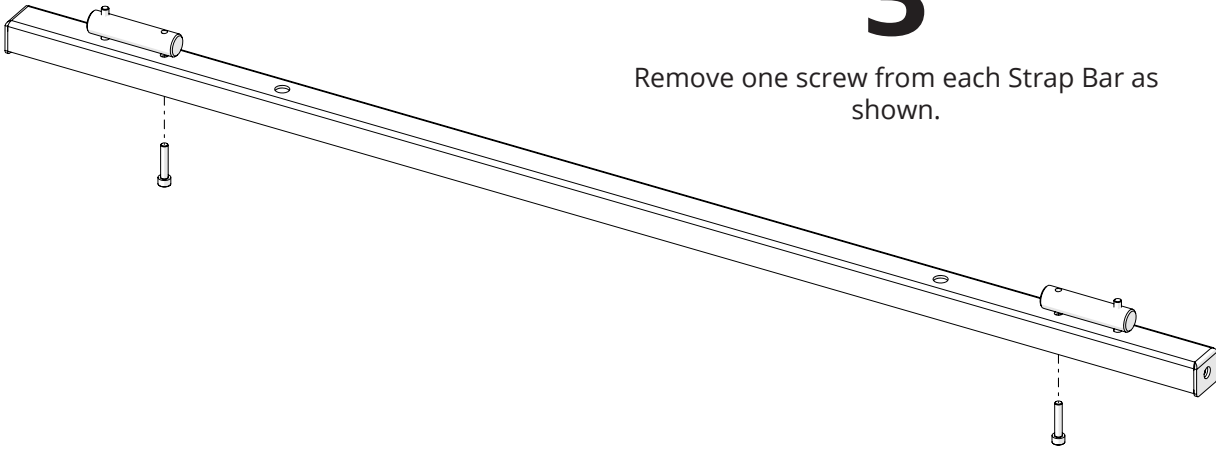

4

Attach Cross Member to the Uprights using the remaining M8 x 16 Cap Head Screws and M8 Nuts. Then hook strap loops over Strap Bars.

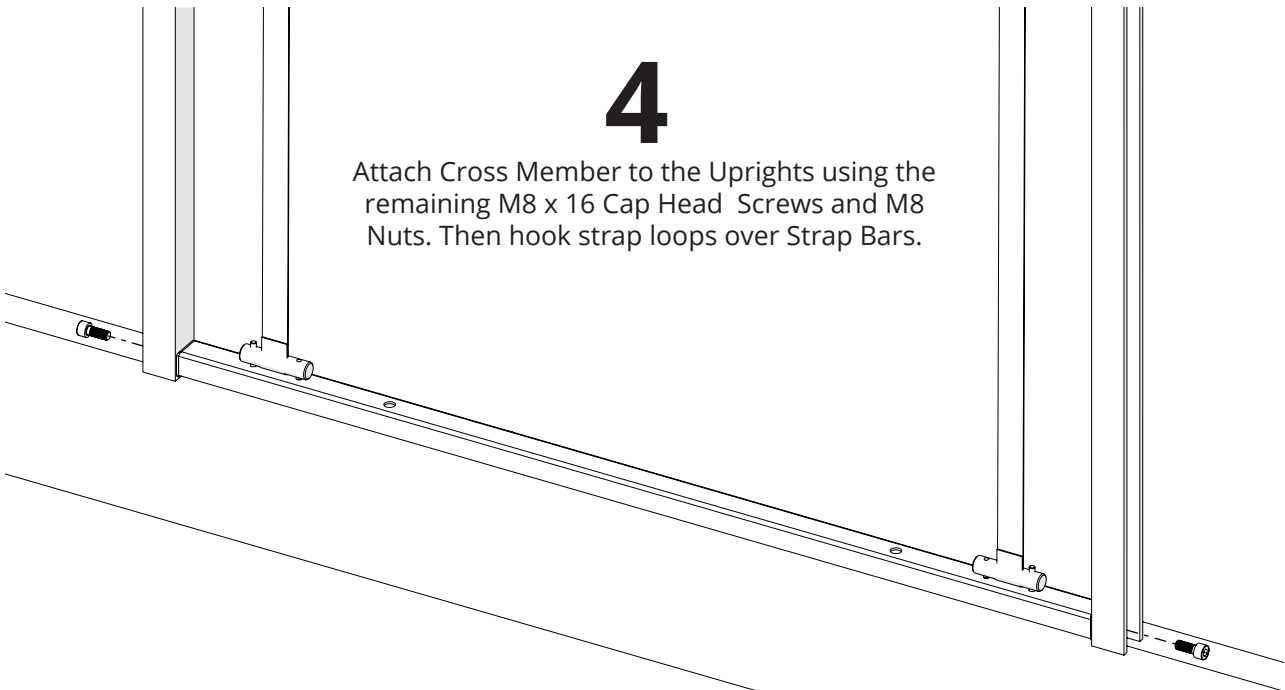

5

Reinsert the screws removed from the Strap Bars earlier.

To level the frame adjust the length of the bolts at the end of the straps.

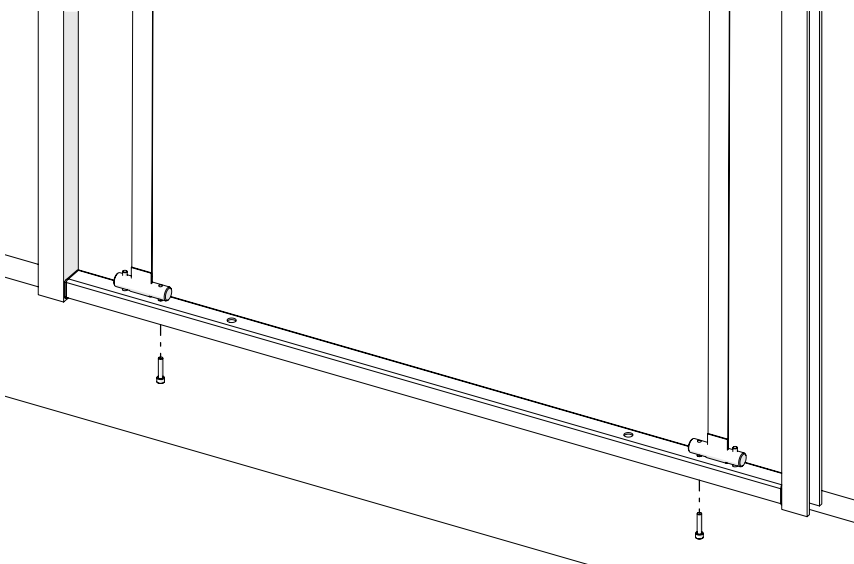

STOP POSITION ADJUSTMENT

In the below view the right hand upright has been removed. It is not necessary to remove this part in order to gain access to the controls, as long as you use a very thin flat head screwdriver.

The two adjusters below can be rotated to change the TOP and BOTTOM positions of the mechanism.

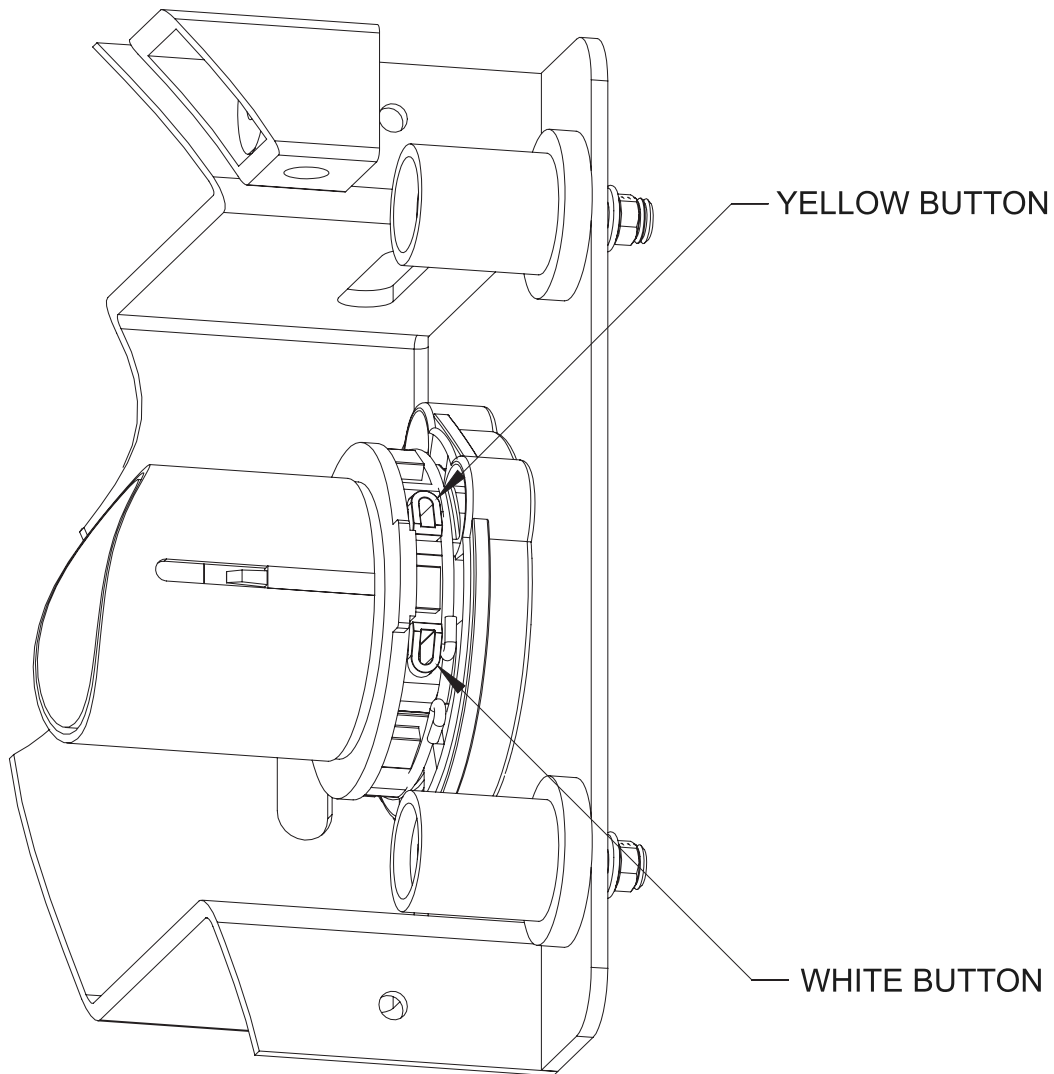

To adjust the top and bottom limits of the mechanism, start by making sure that both the WHITE and YELLOW buttons are fully depressed.

Press IN on the IR Remote control so the mechanism lowers. When the desired position is reached hit STOP on the IR remote control. Then press the YELLOW button so that it pops out, this sets the down limit position.

Carry out the same procedure with the WHITE button when raising the mechanism to set the upper limit position, labelled OUT on the IR remote control.

PICTURE MOUNTING

1

Attach the two Panel Mount Plates to upper inside of picture so that it can be hooked onto the top of the Main Frame. (Fixings NOT provided).

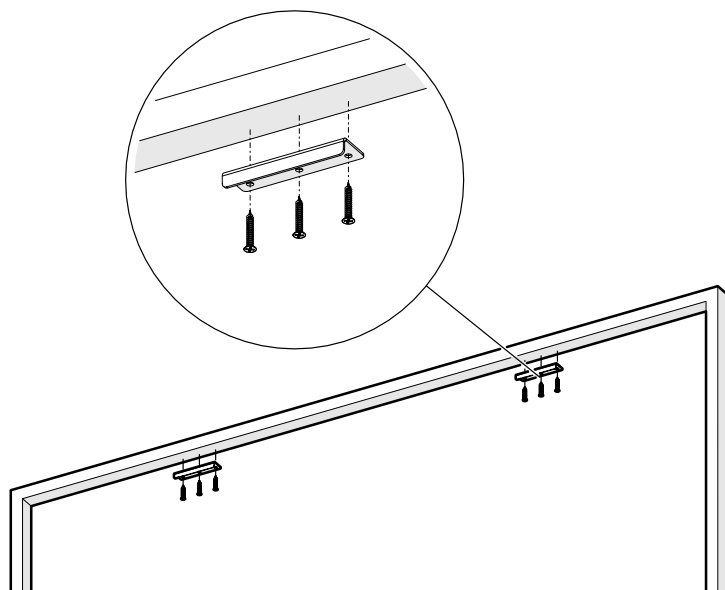

2

The separation of the Panel Mount Brackets should be as shown.

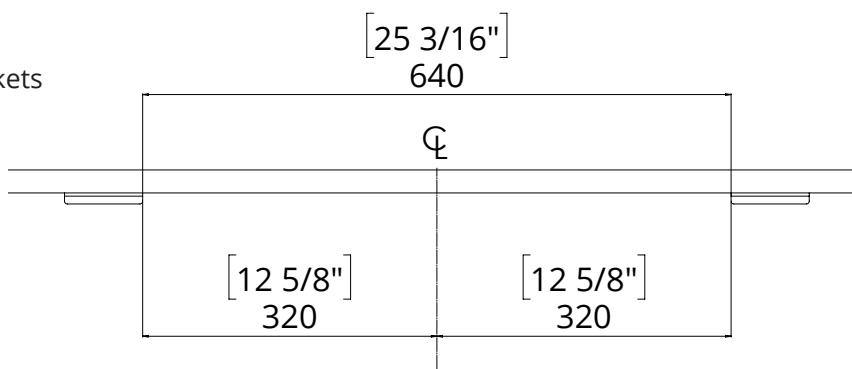

3

Hook the canvas onto the hook brackets so that the canvas sits securely on the mechanism.

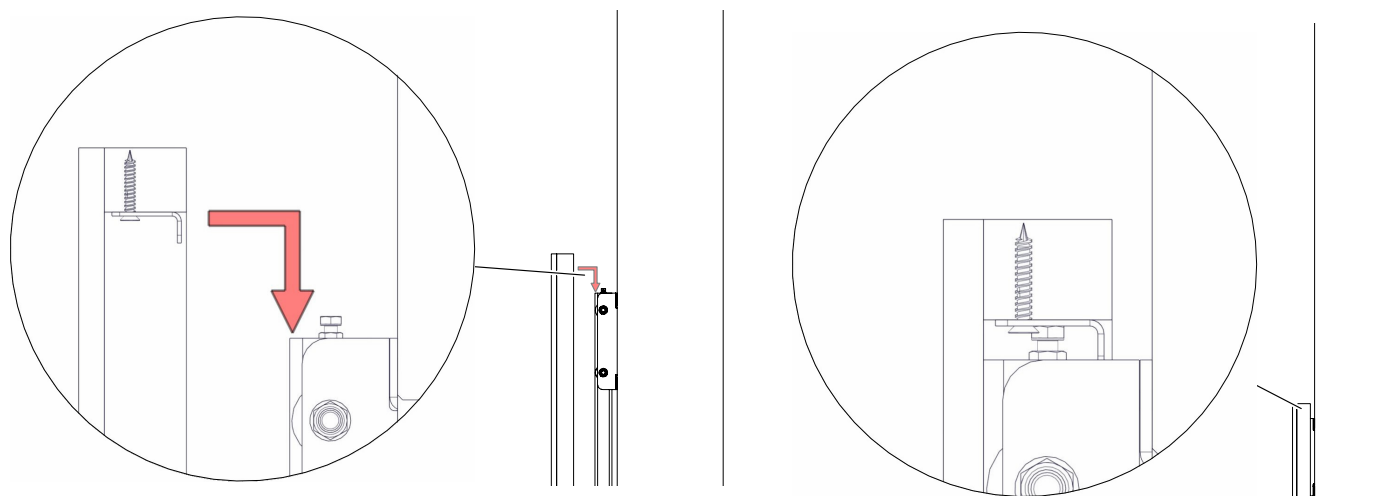

PICTURE MOUNTING CONT.

4

Send Mechanism up so that there is some access to the back of the panel and fix the Panel to the Frame as shown below.
(Fixings NOT provided).

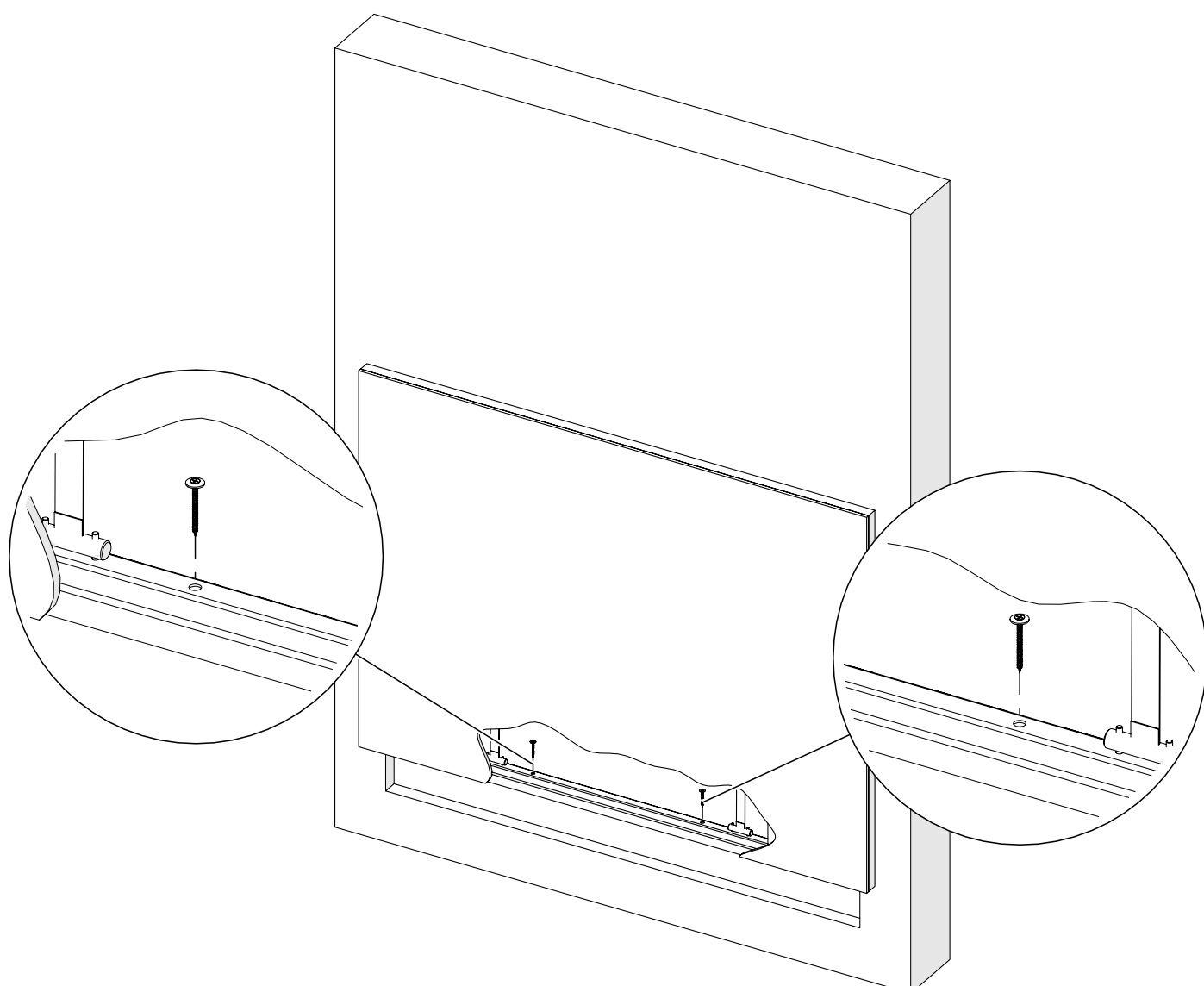

FINAL CHECKS

1

Make sure the mechanism is fixed securely on the wall and that there are no objects obstructing the path of the mechanism.

2

Test the mechanism movement with the canvas in place to see if there are any issues with the movement cycle.

3

Make sure that the TOP and BOTTOM positions are at the desired level.

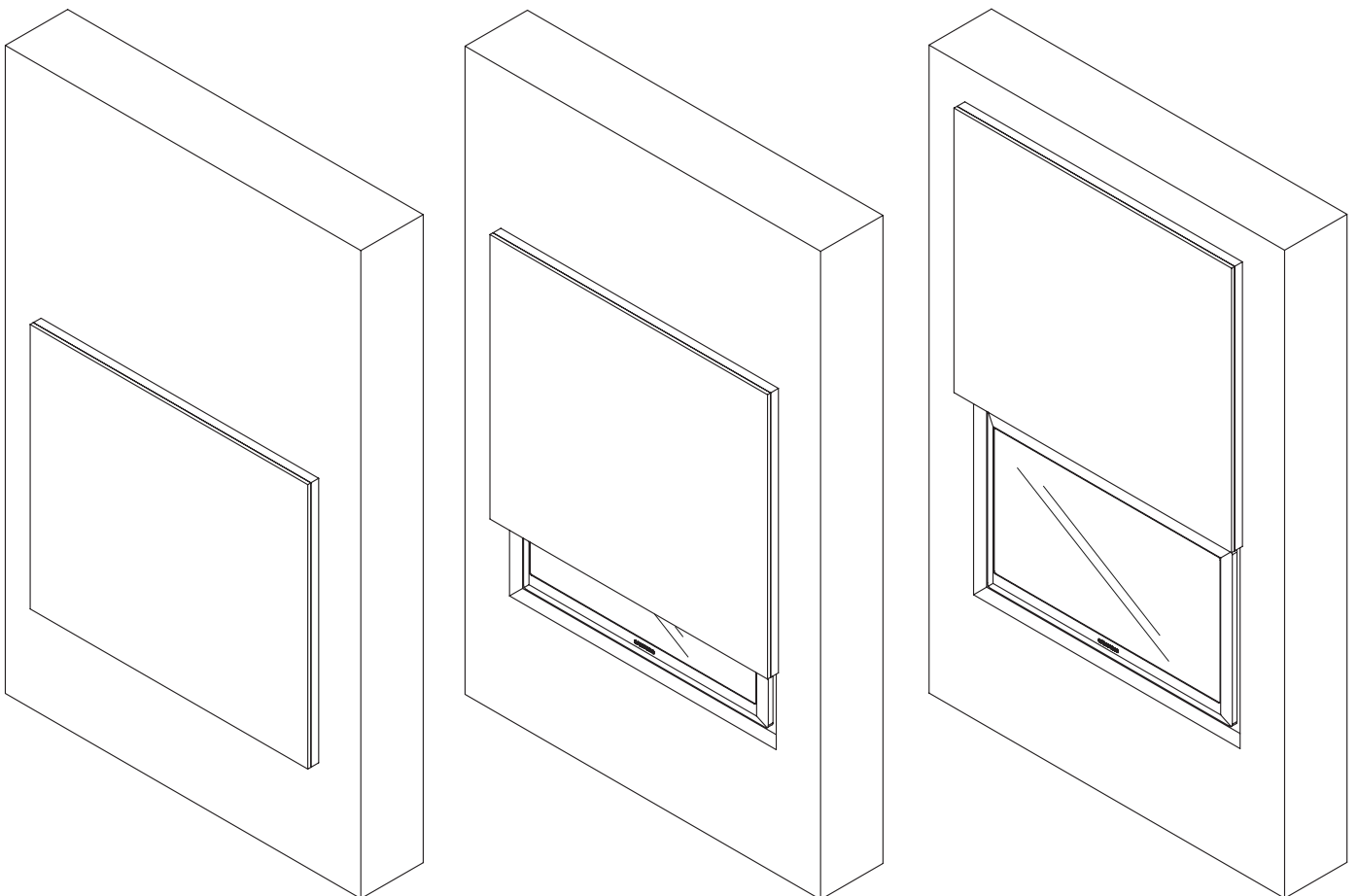

GENERAL CONTROL

This mechanism has multiple standard control methods, each of which requires a different input method to the control box. For ease, the input sockets on the control board are labelled below. **(Control box size and style may vary to image shown)**

CONTROL BOX INPUTS

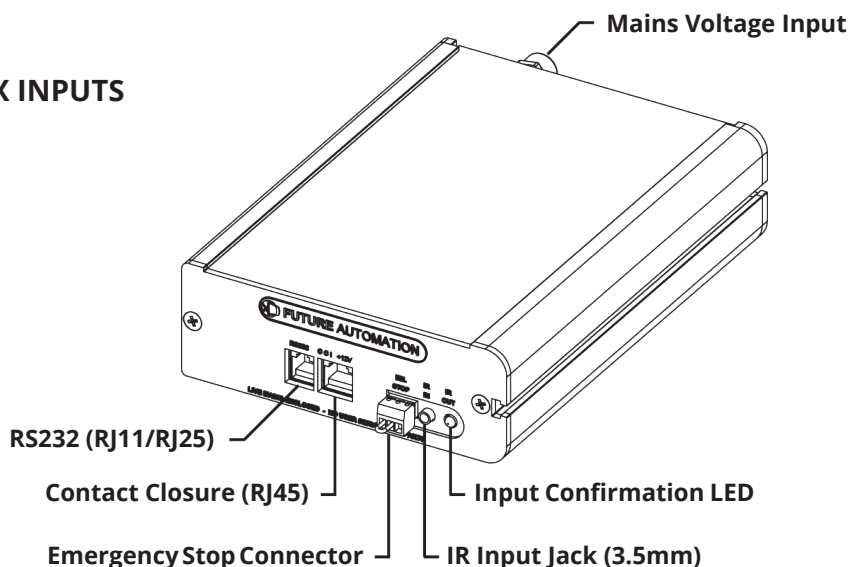

MECHANISM EMERGENCY STOP CONNECTOR

This mechanism features an Emergency Stop Connector, which **MUST** be plugged into the control box in the connector labelled above for the mechanism to operate. If this connector is not plugged in, the Input Confirmation LED will be permanently lit. As per the red plastic tag attached to the Emergency Stop Connector (and shown below), the small loop of wire in this connector is designed to be replaced by a third party safety mechanism.



REPLACING MECHANISM BATTERIES

The standard Future Automation Infrared (IR) remote control required x2 AAA batteries to operate. These are provided with the mechanism in the Accessories Pack. These batteries can be replaced as the per the image below.

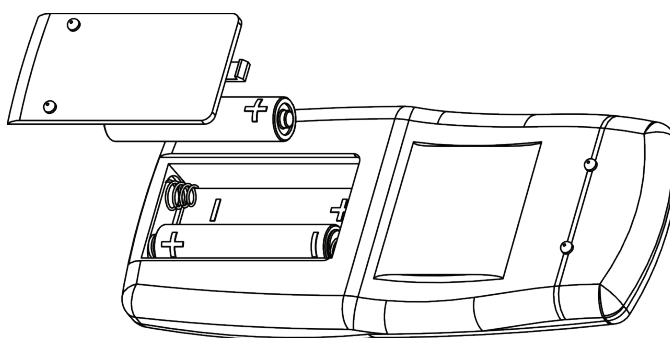

INFRARED (IR)

This mechanism can be controlled via the supplied 14 button Infrared (IR) Remote Control, paired with the supplied Infrared (IR) lead and sensor.

The mechanism's functions can be controlled by plugging the Infrared (IR) lead and sensor into the 3.5mm IR Input Jack shown on the General Mechanism Control page.

Confirmation of Infrared (IR) input will be shown by a single flash of the large green LED located on the end of the control box.

As Infrared (IR) control works over line of site, the Infrared (IR) sensor must be directly viewable from what ever location the remote control is being used from.

Infrared (IR) Remote Control Button Layout

IN - Brings the mechanism into the cabinet.

OUT - Brings the mechanism out of the cabinet.

STOP - Will stop the operation of the mechanism at ANY position.

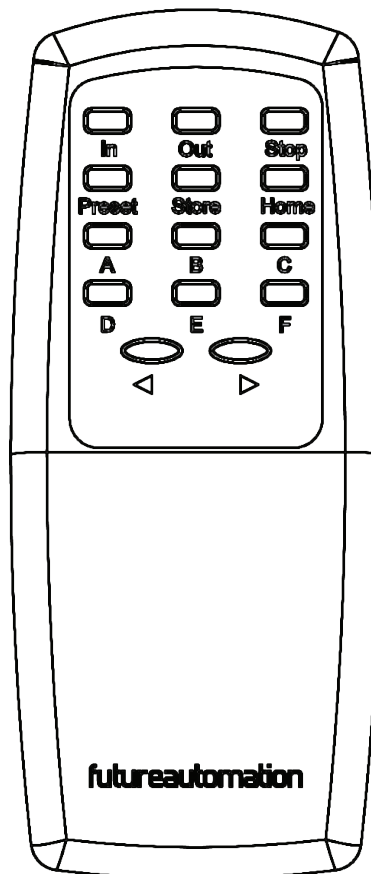

IMPORTANT

Only buttons indicated above are functional with the product. Any other button press will STOP the mechanism.

RADIO FREQUENCY (RF)

If purchased with the Radio Frequency (RF) control option, this mechanism can be controlled via the supplied 4 button Radio Frequency (RF) Remote Control, paired with the in-built Radio Frequency (RF) sensor.

Confirmation of Radio Frequency (RF) input will be shown by a single flash of the large green LED located on the end of the control box.

Radio Frequency (RF) control does not require line of site, but signal can be affected by cabinet thickness, cabinet material or other electronic signals (i.e. strong WIFI signals).

Radio Frequency (RF) Remote Control Button Layout

IN - Brings the mechanism into the cabinet.

OUT - Brings the mechanism out of the cabinet.

STOP - Will stop the operation of the mechanism at ANY position.

STOP - Will stop the operation of the mechanism at ANY position.

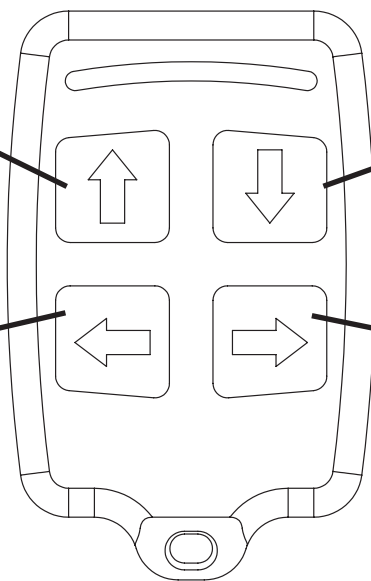

The Radio Frequency (RF) Remote Control can only be used to recall the above functions.

The mechanism limits and preset positions must be programmed using the supplied Infrared (IR) Remote Control.

IMPORTANT

Pressing any button while the mechanism is moving will STOP the mechanism.

CONTACT CLOSURE

This Mechanism can be controlled via Contact Closure, utilising an 8 Pin RJ45 Connector attached to a length of CAT5 (Type 568A or 568B) cable.

The mechanism's functions can be controlled by plugging this into the RJ45 port on the mechanism control board, then shorting pins 1-8 on this connector as shown in the Contact Closure Input Table below.

Confirmation of Contact Closure input will be shown by a single flash of the large green LED located on the end of the control box, as well as illumination of the corresponding Contact Closure LED on the printed circuit board as shown below.

RJ45 PIN LAYOUT

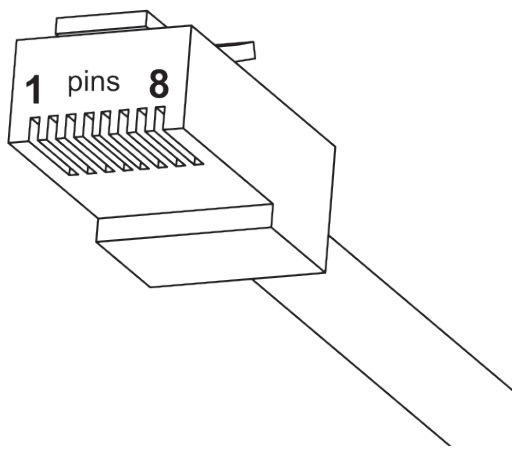

CONTACT CLOSURE LED LAYOUT

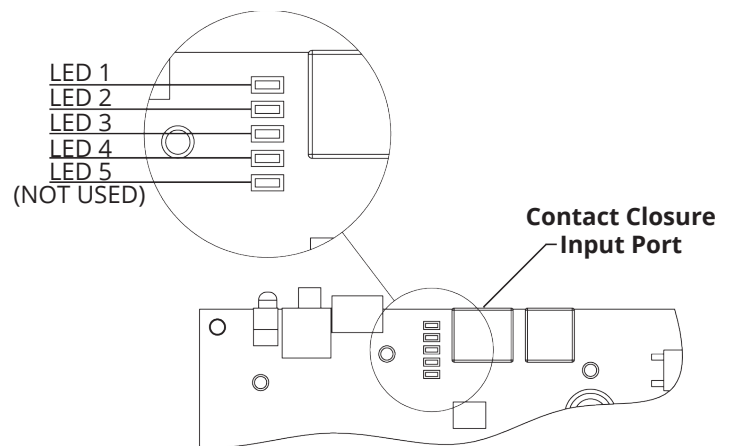

CONTACT CLOSURE INPUT TABLE

PIN	DESCRIPTION	ACTION
1	12V SUPPLY	12V SUPPLY - CURRENT LIMITED
2	12V LATCH	WHEN 12V ATTACHED, DEVICE WILL GO OUT TO PRESET POSITION. WHEN 12V REMOVED, DEVICE WILL GO IN.
3	GROUND	GROUND
4		
5	DEVICE LATCH	SHORT TO GROUND (PIN 3), DEVICE WILL GO OUT TO PRESET POSITION, REMOVE SHORT DEVICE WILL GO IN.
6	DEVICE STOP	MOMENTARY SHORT TO GROUND (PIN 3), STOPS DEVICE IN CURRENT POSITION.
7	DEVICE OUT	MOMENTARY SHORT TO GROUND (PIN 3), MAKES DEVICE GO OUT.
8	DEVICE IN	MOMENTARY SHORT TO GROUND (PIN 3), MAKES DEVICE GO IN.

WIRE/CABLE TYPE		LED INDICATOR
568A	568B	
W G	W O	
G O	O G	
W O	W G	
B B	B B	
W B	W B	LED 4
O O	G G	LED 3
W BR	W BR	LED 2
BR BR	BR BR	LED 1

RS232 CONTROL

This Mechanism can be controlled via RS232, utilising a 6 Pin RJ11/RJ25 connector OR 9 Pin Serial connector attached to a length of 6 core cable.

The mechanism's functions can be controlled by plugging this into the RJ11/RJ25 port on the mechanism control box, then inputting the RS232 commands shown in the RS232 Input Table below.

Confirmation of Contact Closure input will be shown by a single flash of the large green LED located on the end of the control box.

RJ11/RJ25 PIN LAYOUT

PIN 1: RX
PIN 6: TX
PIN 3 & 4: GROUND

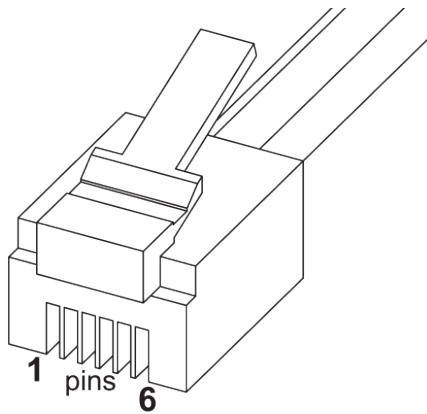

SERIAL PIN LAYOUT

PIN 2: RX
PIN 3: TX
PIN 5: GROUND

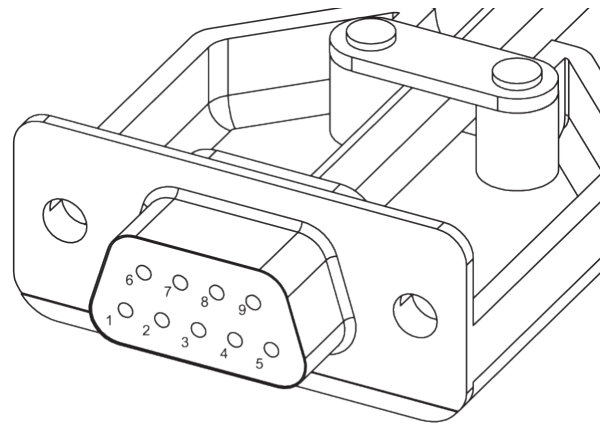

RS232 PROGRAMMING DETAILS

Baud Rate: 9600

Stop Bit: 1

Parity: None

Databits: 8

RJ11/RJ25	Func.	9 PIN Serial	Colour
PIN 1	TX-RX	PIN 2	Blue
PIN 3	GROUND	PIN 5	Green
PIN 4	GROUND	PIN 5	Red
PIN 6	RX-TX	PIN 3	White

RS232 INPUT TABLE

IMPORTANT - Ensure all protocols are entered exactly as written below, including Carriage Return (ENTER / ASCII 13)

Protocol	Action
fa_in Carriage Return (Enter / ASCII 13)	Device IN
fa_out Carriage Return (Enter / ASCII 13)	Device OUT
fa_stop Carriage Return (Enter / ASCII 13)	Device STOP (At any position)



EUROPEAN OFFICE

Address:
Unit 6-8
Brunel Road
Bedford
Bedfordshire
MK41 9TG

Phone: +44 (0) 1438 833577
Email: info@futureautomation.co.uk

Office Hours:
Mon - Fri 8:00 to 17:30 GMT
Saturday & Sunday - Closed

NORTH AMERICAN OFFICE

Address:
Enterprise Park
127 Venture Drive
Dover
NH
03820

Phone: +1 (603) 742 9181
Email: info@futureautomation.net

Office Hours:
Mon - Fri 7:00 to 17:00 EST
Saturday & Sunday - Closed