

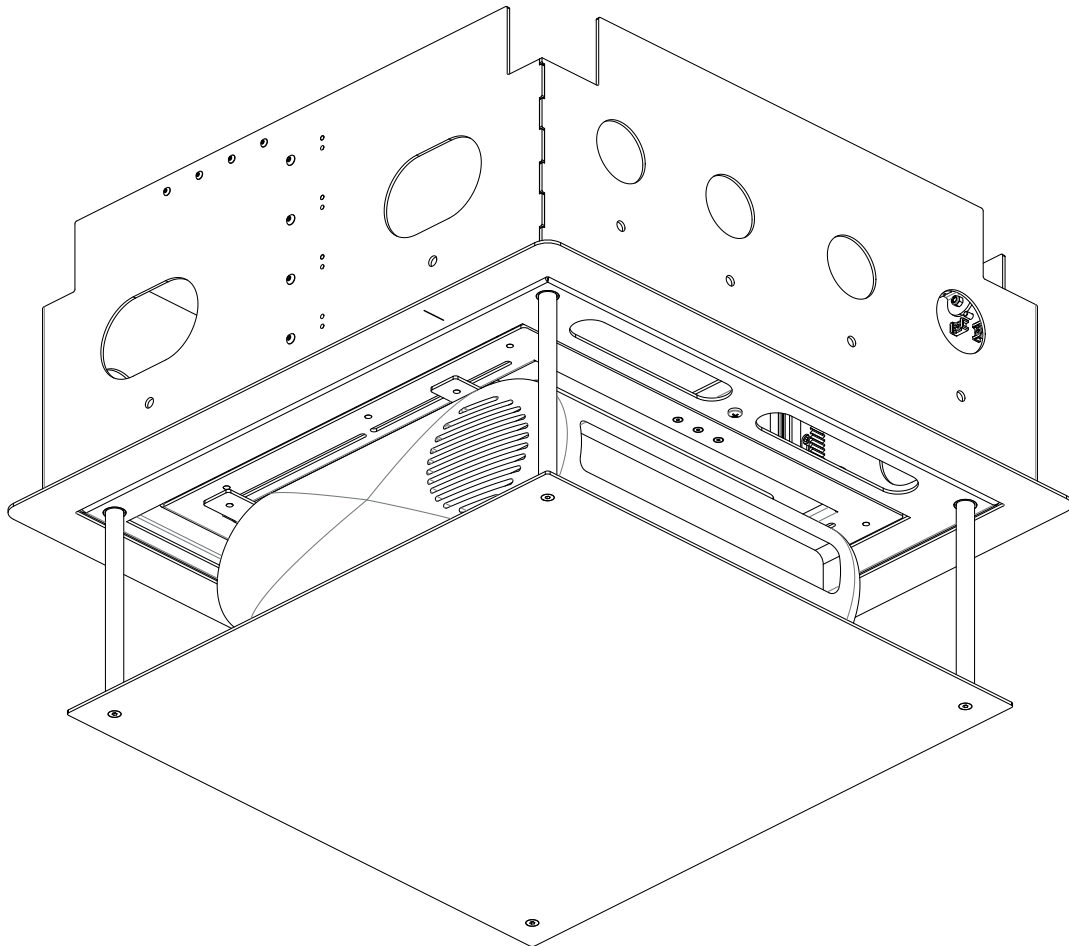

future automation

# PDM

PDM1 / PDM2 / PDM3  
INDOOR MARINE PROJECTOR LIFT



## INSTALLATION INSTRUCTIONS

ISSUE 010



# SAFETY DISCLAIMER

## IMPORTANT SAFETY INSTRUCTIONS BELOW

**WARNING:** Failure to provide adequate structural strengthening, prior to installation can result in serious personal injury or damage to the equipment. It is the installer's responsibility to ensure the structure to which the component is affixed can support four times the weight of the component and any additional apparatus mounted to the component.

**WARNING:** Do not exceed the weight capacity for this product as listed below. This can result in serious personal injury or damage to the equipment. It is the installer's responsibility to ensure that the total combined weight of all attached components does not exceed that of the maximum figure stated.

**WARNING:** Risk of death or serious injury may occur when children climb on audio and/or video equipment or furniture. A remote control or toys placed on the furnishing may encourage a child to climb on the furnishing and as a result the furnishing may tip over on to the child.

**WARNING:** Risk of death or serious injury may occur. Relocating audio and/or video equipment to furniture not specifically designed to support audio and/or video equipment may result in death or serious injury due to the furnishing collapsing or over turning onto a child or adult.



Only for use with equipment weighing **55LBS (25KG) OR LESS.**

Use with heavier projectors/equipment may lead to instability causing  
tip over or failure resulting in death or serious injury.

Bracket Suitable for Residential and Commercial Use.

### ADDITIONAL WARNINGS:

1. Keep all documentation/instructions after fitting.
2. Read all technical instructions fully before installation and use. It is the installer's responsibility to ensure that all documentation is passed on to the end user and read fully before operation.
3. Do not use near water or outdoors unless the product has been specifically designed to do so.
4. Protect any cables or cords being used near this bracket from being walked on or pinched to prevent damage and risk of injury.
5. Use this product only for its intended purpose as described in the product instructions and only use attachments/accessories specified by the manufacturer.
6. Do not operate the product if it is damaged in any way, liquid has been spilled or objects have fallen into the apparatus, the apparatus has been exposed to rain or moisture, does not operate normally, or has been dropped. Contact the original installer/manufacturer to arrange repair or return.

### WARNING - To reduce the risk of burns, fire, electric shock, or injury to persons:

1. Clean only with a dry cloth and always unplug any electrical items being used in conjunction with this product before cleaning.

Future Sound & Vision trading as Future Automation intend to make this and all documentation as accurate as possible. However, Future Automation makes no claim that the information contained herein covers all details, conditions or variations, nor does it provide for every possible contingency in connection with the installation or use of this product. The information contained in this document is subject to change without prior notice or obligation of any kind. Future Automation makes no representation of warranty, expressed or implied, regarding the information contained herein. Future Automation assumes no responsibility for accuracy, completeness or sufficiency of the information contained in this document.

# PRODUCT WARRANTY & RISK ASSESSMENT

## WARRANTY INFORMATION

**WARNING - The warranty offered for this product shall be annulled if the product is used improperly or in a way that is in breach of our Terms of Service.**

Future Automation provides warranty for the mechanism you purchased for the period of **24 months** from the date of purchase, provided that it isn't used for unintended purposes.

Under the warranty, Future Automation aims to either solve the issue remotely (via telephone or email support) or if the mechanism requires a part, arrange a visit to your premises by a Future Automation approved engineer or send replacement items where appropriate.

Warranty repairs will be carried out as quickly as possible, but subject to parts availability. This warranty period is respectively extended for the period of a repair.

A malfunctioning product must be cleaned and placed into suitable packaging to protect against transit damage before organising delivery to a repair workshop.

All the complaints about defects must be submitted to the vendor/installer that sold this product, rather than directly to the manufacturer.

Any part of your system that needs to be replaced during a warranty repair becomes the property of Future Automation.

### **The warranty does not cover the following:**

- Damages resulting from improper product use or maintenance.
- Repairs carried out by unauthorized persons.
- Natural wear and tear during operation.
- Damages caused by the buyer.
- Accidental damages caused by a customer or damages caused as a result of careless attitude or usage, or damages caused by natural disasters (natural phenomena).
- Any electrical, or other environmental work external to your Future Automation mechanism including power cuts, surges etc.
- Additional items not supplied by Future Automation although they may have been supplied together by the retailer
- Any 3rd party software products controlling your mechanism
- Any transfer of ownership. Warranty is provided only to the initial purchaser.
- Compensation for loss of use of the product, and consequential loss of any kind.

A separate Safety and Servicing Information document is provided with these instructions (additional copies can be found at [www.futureautomation.co.uk/safety](http://www.futureautomation.co.uk/safety)), and this document **MUST** be filled out by the approved Future Automation Dealer who is installing the product. This Warranty Sheet must be held by the end user for the duration of the products life and will be referred to during servicing or warranty queries.

The Safety and Servicing Information document also contains two Service History Forms that must be filled in by the approved Future Automation dealer who is performing the first required yearly service of this product.

**One copy of the Service History Form must be held by the customer (along with the Warranty Sheet) and a duplicate copy must be held by the approved Future Automation dealer that performed the service. Missing and/or mismatching documents may delay or invalidate warranty claims.**

Additional Service History Forms can be found on the Future Automation website for further yearly services.

## RISK ASSESSMENT INFORMATION

It is the installer's responsibility to perform a risk assessment of installed products. Future Automation can provide guidelines to installers/dealer about what should be included in a risk assessment, but due to the individual nuances of each location/site, Future Automation cannot provide a full list of areas to risk assess.

For full risk assessment and safety information please view our Safety and Servicing guide available at [www.futureautomation.net/safety](http://www.futureautomation.net/safety)

# GUIDE CONTENTS

SAFETY DISCLAIMER	<b>1</b>
PRODUCT WARRANTY & RISK ASSESSMENT	<b>2</b>
GUIDE CONTENTS	<b>3</b>
PACKAGE CONTENTS	<b>4</b>
MECHANISM QUICK-START GUIDE	<b>5</b>
INITIAL OPERATION	<b>6</b>
CEILING CUT OUT	<b>7</b>
MECHANISM INSTALLATION	<b>8</b>
PROJECTOR INSTALLATION	<b>9</b>
FITTING BOTTOM PLATE	<b>10</b>
FINAL/PERIODIC CHECKS	<b>11</b>
GENERAL CONTROL	<b>12</b>
INFRARED (IR)	<b>13</b>
RADIO FREQUENCY (RF)	<b>14</b>
CONTACT CLOSURE	<b>15</b>
RS232 CONTROL	<b>16</b>
SCREEN CONTROL	<b>17</b>

# PACKAGE CONTENTS

## 1 - PDM1/PMD2/PDM3

- 1.1 - MAIN BOX
- 1.2 - MOUNT PLATE
- 1.3 - MOUNT BRACKETS
- 1.4 - PDM POST LEGS
- 1.5 - BOTTOM LID

## 2 - CONTROL BOX (SIZE/STYLE MAY VARY)

## 3 - IR REMOTE

### ITEMS NOT SHOWN ON PAGE:

- PDM ACCESSORY PACK
- X2 AAA BATTERIES
- MULTI-PACK OF NUTS, BOLTS AND WASHERS
- MAINS POWER, IR AND CONTACT CLOSURE LEADS

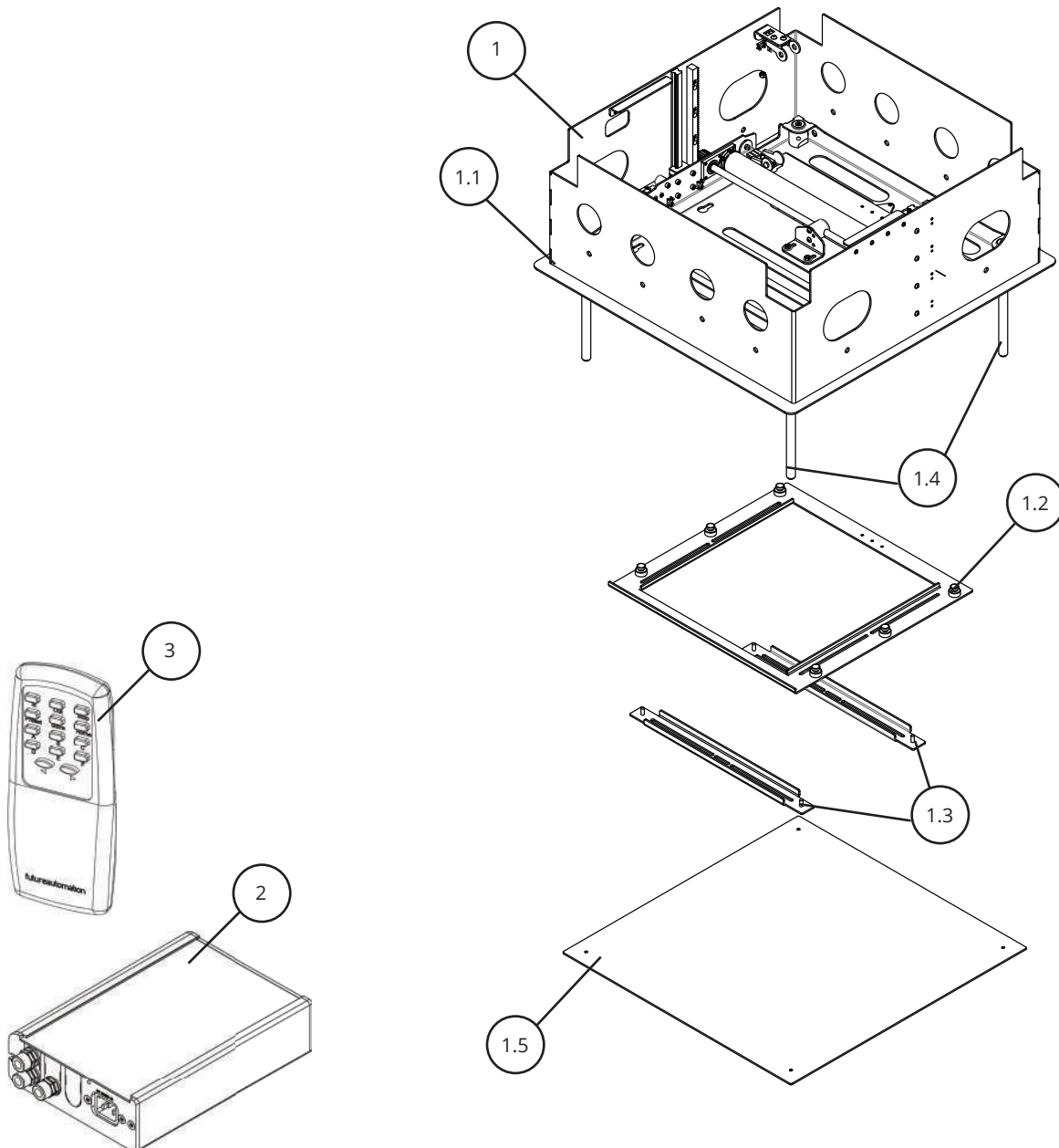

# MECHANISM QUICK-START GUIDE

Some Future Automation mechanisms may ship with the control box disconnected to prevent damage during transit. In order to operate the mechanism, the control box will need to be reconnected, then have mains power applied along with the desired control method.

## RECONNECTING THE CONTROL BOX

To reconnect the mechanism control box, follow the below steps:

1. Make sure the power is disconnected from the control box.
2. Remove the retaining screw and washer from the end of the control box to allow removal of the control box lid. (Image 1 Below).
3. Slide off the control box lid to reveal the control board inside.
4. Locate the green connector on the end of the loom leading from the lift mechanism. This plug will have a small tag attached stating the correct connecting socket on the control board (e.g. "AC1", "DC2"...). (Image 2 Below).
5. Plug the green connector into the corresponding socket on the control board. This plug is handed and will only connect correctly one way. Do NOT force the connector into the socket, this can cause serious damage to the control board and mechanism.
6. Route the wiring loom out of the end of the control box by inserting the black plastic inserts into the slots provided. (Image 3 Below).
7. Slide the control box cover back over the control board and replace the fixing screw and washer.



Image 1.

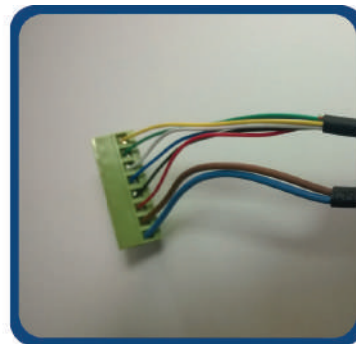

Image 2.



Image 3.



Image 4.

## IMPORTANT

For the mechanism to operate, the green three way safety connector with the loop of wire attached, must also be plugged into the end of the control box. (Image 4 above). If this connector is not plugged in, a bright red LED will be visible inside control board and the Input Confirmation Input LED will be permanently illuminated.

# INITIAL OPERATION

## 1

- Unpack and check the mechanism fully for any damage or obvious visual faults before operation.

## 2

- Connect the mechanisms control box up to the mains power and plug in the Infrared (IR) sensor.
- This is a good time to check that the location that the control will sit in after installation is suitable. The control box needs to be located somewhere is easy future access for maintenance and servicing. The power and signal cables running from the control box to the mechanism can easily be extended on site if required.

## 3

- Test the mechanism by running it fully up and down once (refer to the mechanism control section of the instructions for more details).



# CEILING CUT OUT

## 1

- The ceiling cut out to house the Marine Projector Lift mechanism should be cut to the dimensions shown on the relevant Marine Projector Lift Technical Sheet.
- The ceiling cut out space should be free from obstructions such as pipes, cables or joists.

## 2

- Joists should be put in place to support the Marine Projector Lift mechanism front and back

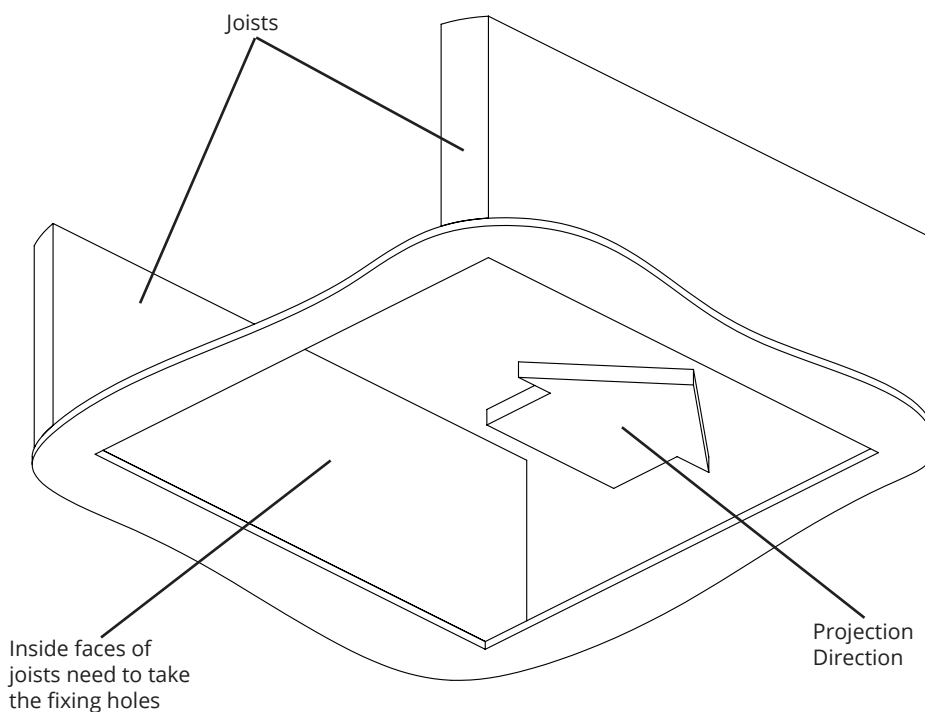

### Ceiling cut out sizes for Marine Projector Lifts;

PDM1;

- L580mm [22.8"] x W580mm [22.8"]

PDM2:

- L630mm [24.8"] x W630mm [24.8"]

PDM3:

- L810mm [31.9"] x W810mm [31.9"]

# MECHANISM INSTALLATION

## 1

- Remove the Marine Projector Lift Bottom Plate by removing the 4 fixings on the underside of the plate. These hold the lift to the 4 PDM Post Legs.
- Remove the Locking Plate from the Marine Projector Drop by sliding it towards the front of the mechanism, then down out of its keyhole fixings.
- Bring the projector power and source cables out of the ceiling and run them through the marked cable management holes towards the rear of the mechanism.

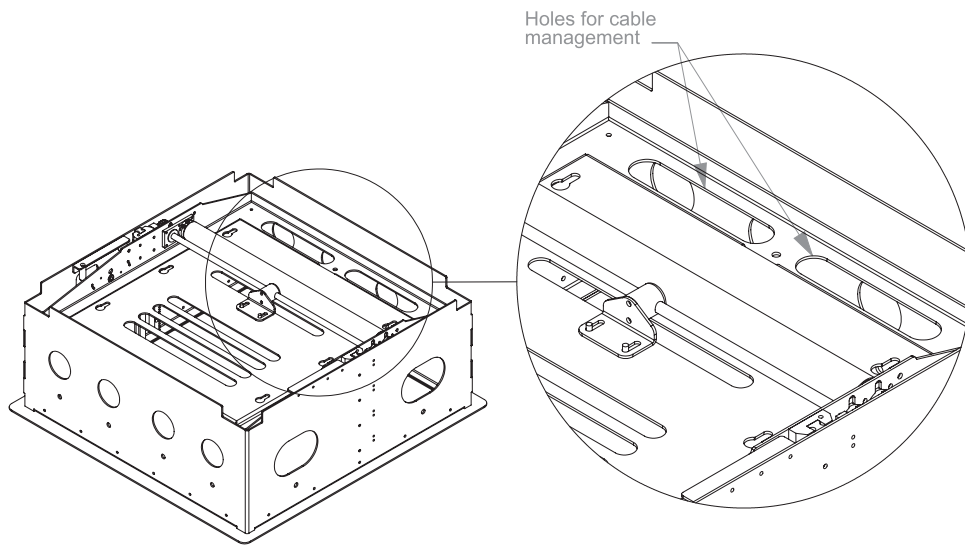

## 2

- Place the Marine Projector Lift mechanism into the ceiling and fix to the joists using the fixing holes on the front and back of the Projector Lift. The PDM1/PDM2 will require 8 fixings, while the PDM3 will require 10 fixings.

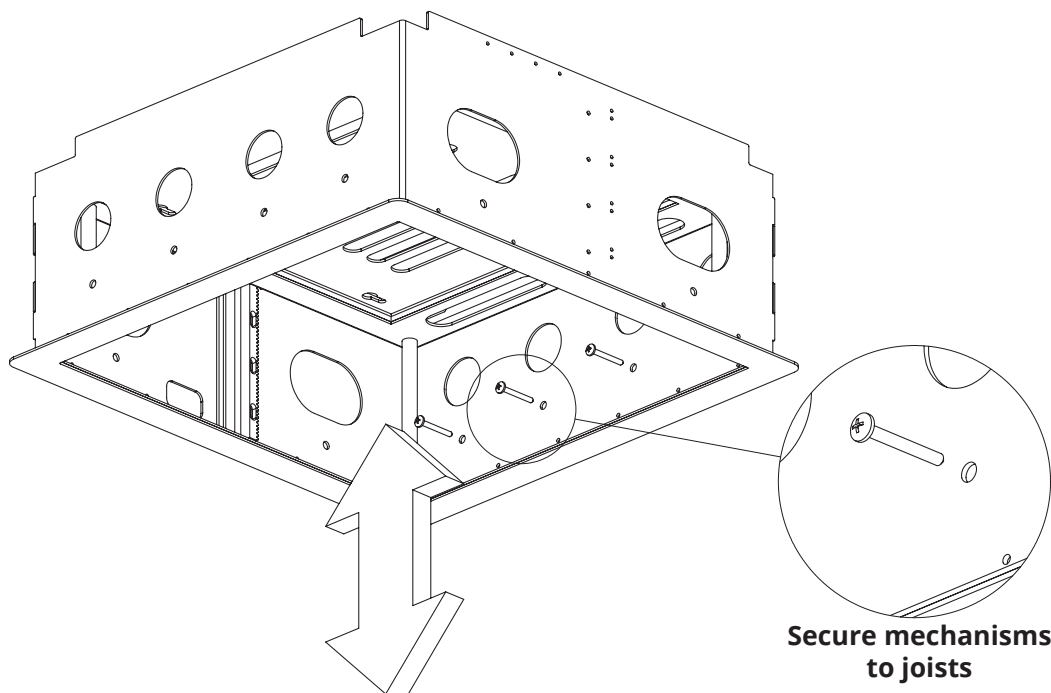

# PROJECTOR INSTALLATION

## 1

- Loosen the nuts that secure the Mount Brackets to the Mount Plate and slide the Mount Brackets forwards or back to match the spacing on the projector mounting holes. Tighten the nuts to secure in place and then fix the projector to the Mount Brackets as shown below.

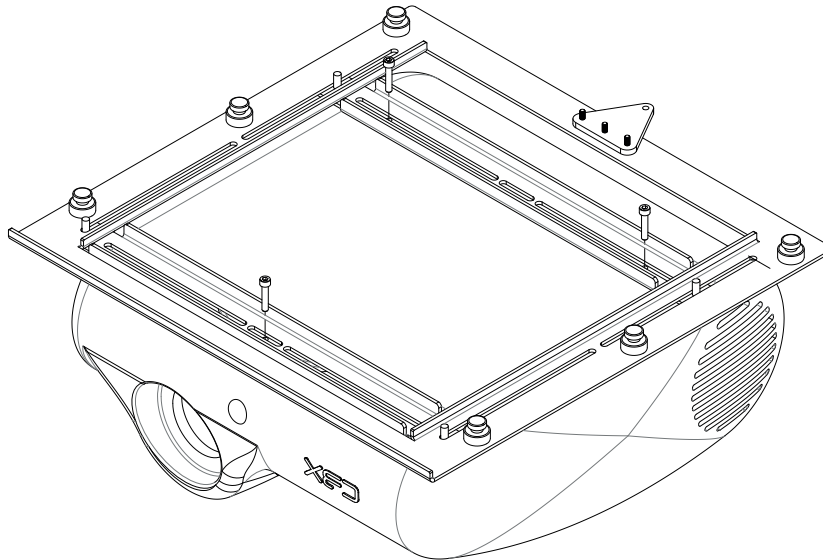

## 2

- Fit the Mount Plate and projector in to the Marine Projector Drop mechanism by lifting the Locking Plate into the mechanism and sliding it back onto its keyhole fixings.
- Connect the projector's power and source cables, making sure the cables have enough slack to allow the projector to lower.

## 3

- Secure the projector and Locking Plate in place by fitting the Locking Bolt shown below at the rear of the Locking Plate.

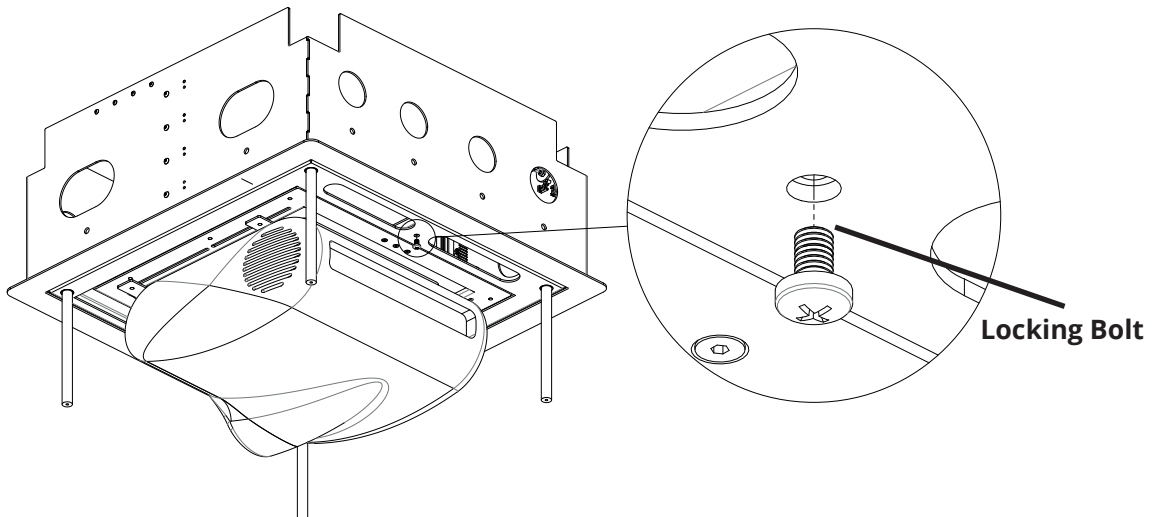

# FITTING BOTTOM PLATE

## 1

- Reattach the Bottom Plate to the Marine Projector Drop using the four countersunk bolts provided with it.

## 2

- Double check the Bottom Plate and Locking Plate are securely fitted to the mechanism.

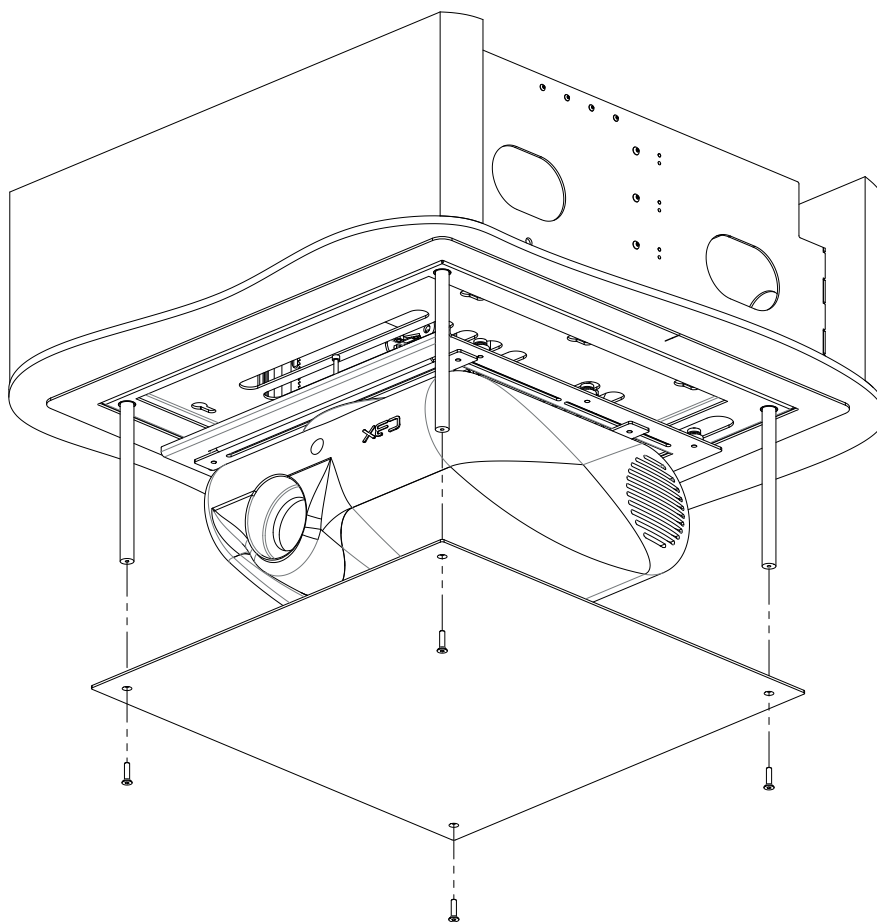

# FINAL/PERIODIC CHECKS

## 1

- Check the mechanism is operating correctly.
- Check the projector is secure during transportation.
- Check cable routing and check that enough slack is left for free movement.
- Check the Bottom Plate is securely fastened to the mechanism.

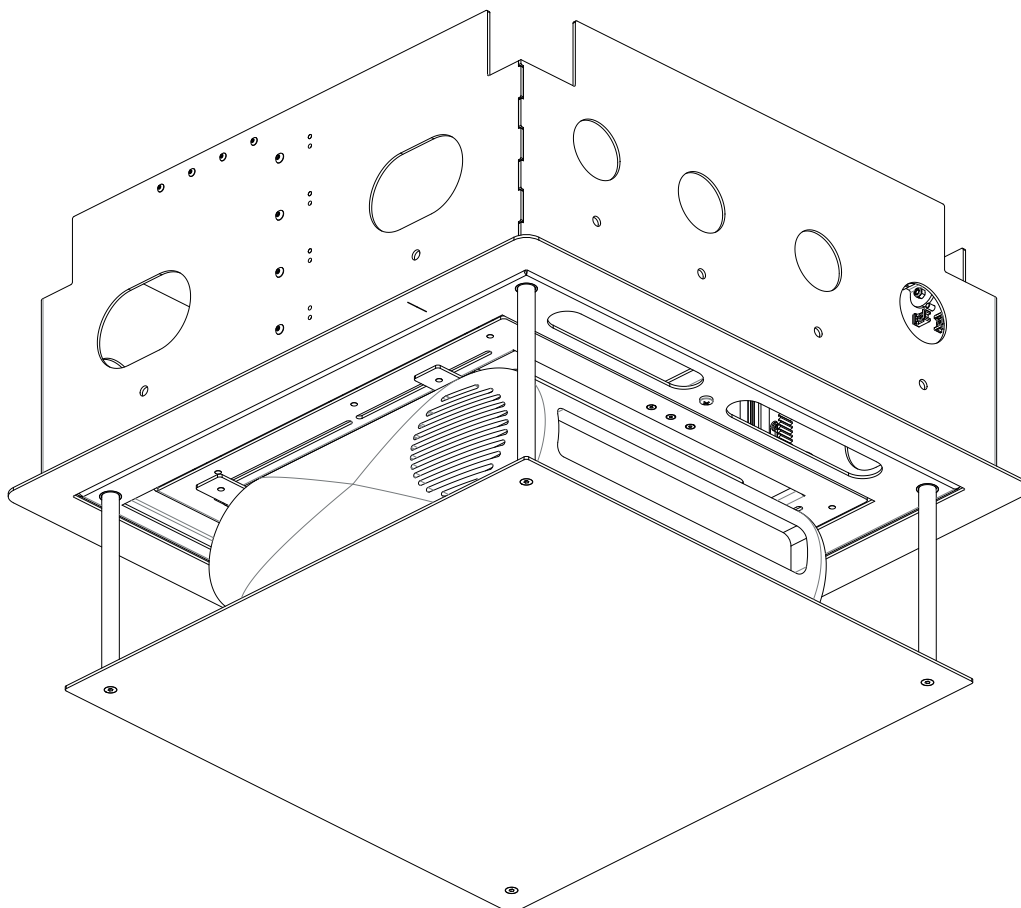

# GENERAL CONTROL

This mechanism has multiple standard control methods, each of which requires a different input method to the control box. For ease, the input sockets on the control board are labelled below. **(Control box size and style may vary to image shown)**

## CONTROL BOX INPUTS

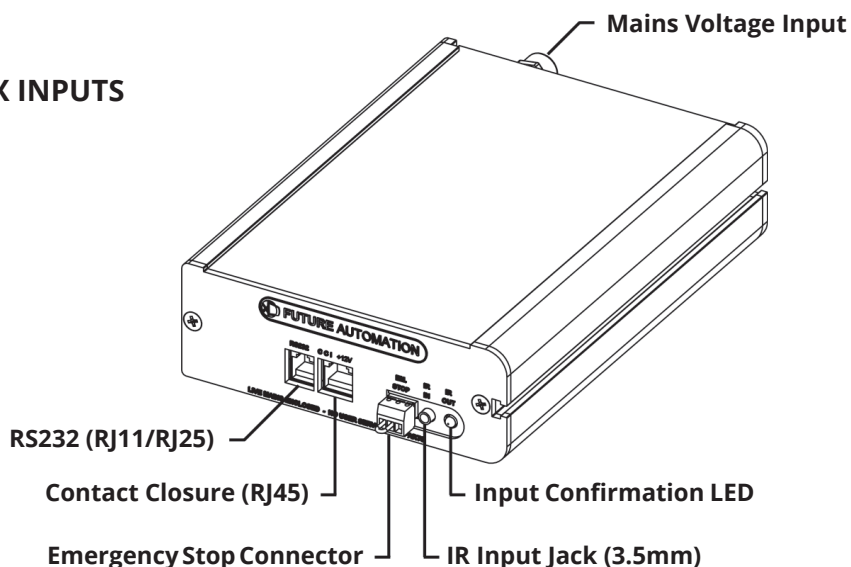

## MECHANISM EMERGENCY STOP CONNECTOR

This mechanism features an Emergency Stop Connector, which **MUST** be plugged into the control box in the connector labelled above for the mechanism to operate. If this connector is not plugged in, the Input Confirmation LED will be permanently lit. As per the red plastic tag attached to the Emergency Stop Connector (and shown below), the small loop of wire in this connector is designed to be replaced by a third party safety mechanism.



## REPLACING MECHANISM BATTERIES

The standard Future Automation Infrared (IR) remote control required x2 AAA batteries to operate. These are provided with the mechanism in the Accessories Pack. These batteries can be replaced as per the image below.

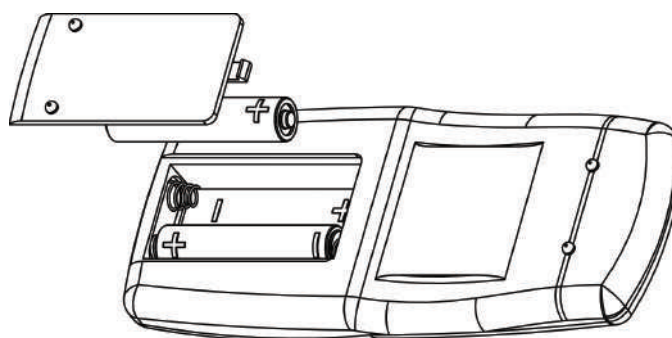

# INFRARED (IR)

This mechanism can be controlled via the supplied 14 button Infrared (IR) Remote Control, paired with the supplied Infrared (IR) lead and sensor.

The mechanism's functions can be controlled by plugging the Infrared (IR) lead and sensor into the 3.5mm IR Input Jack shown on the General Mechanism Control page.

Confirmation of Infrared (IR) input will be shown by a single flash of the large green LED located on the end of the control box.

As Infrared (IR) control works over line of site, the Infrared (IR) sensor must be directly viewable from what ever location the remote control is being used from.

## Infrared (IR) Remote Control Button Layout

**IN** - Brings the mechanism into the cabinet.

**OUT** - Brings the mechanism out of the cabinet, without swivelling.

**STOP** - Will stop the operation of the mechanism at ANY position.

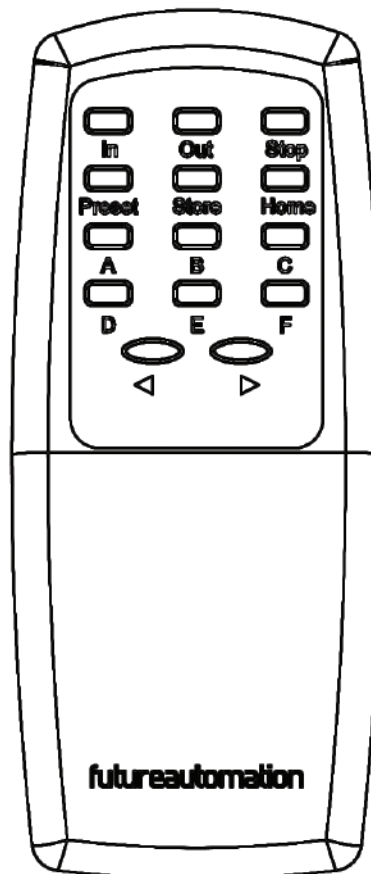

### IMPORTANT

Only buttons indicated above are functional with the product. Any other button press will STOP the mechanism.

# RADIO FREQUENCY (RF)

If purchased with the Radio Frequency (RF) control option, this mechanism can be controlled via the supplied 4 button Radio Frequency (RF) Remote Control, paired with the in-built Radio Frequency (RF) sensor.

Confirmation of Radio Frequency (RF) input will be shown by a single flash of the large green LED located on the end of the control box.

Radio Frequency (RF) control does not require line of site, but signal can be affected by cabinet thickness, cabinet material or other electronic signals (i.e. strong WIFI signals).

## Radio Frequency (RF) Remote Control Button Layout

**IN** - Brings the mechanism into the cabinet.

**OUT** - Brings the mechanism out of the cabinet, without swivelling.

**STOP** - Will stop the operation of the mechanism at ANY position.

**STOP** - Will stop the operation of the mechanism at ANY position.

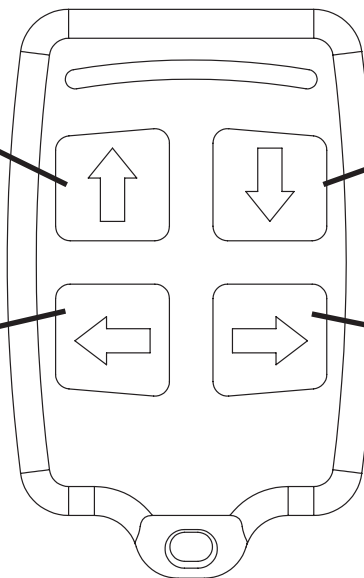

The Radio Frequency (RF) Remote Control can only be used to recall the above functions.

**The mechanism limits and preset positions must be programmed using the supplied Infrared (IR) Remote Control.**

### **IMPORTANT**

Pressing any button while the mechanism is moving will STOP the mechanism.



# CONTACT CLOSURE

This Mechanism can be controlled via Contact Closure, utilising an 8 Pin RJ45 Connector attached to a length of CAT5 (Type 568A or 568B) cable.

The mechanism's functions can be controlled by plugging this into the RJ45 port on the mechanism control board, then shorting pins 1-8 on this connector as shown in the Contact Closure Input Table below.

Confirmation of Contact Closure input will be shown by a single flash of the large green LED located on the end of the control box, as well as illumination of the corresponding Contact Closure LED on the printed circuit board as shown below.

## RJ45 PIN LAYOUT

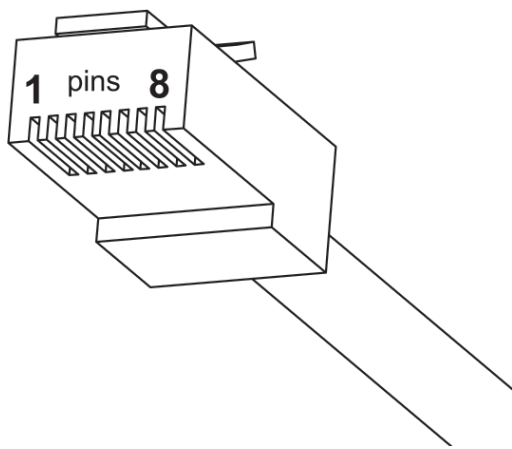

## CONTACT CLOSURE LED LAYOUT

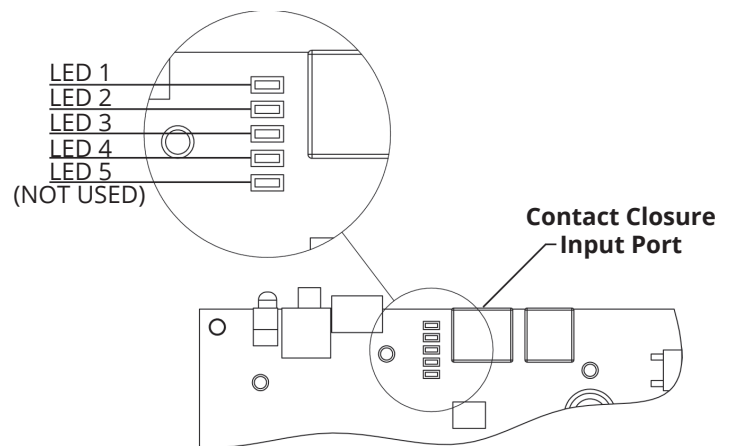

## CONTACT CLOSURE INPUT TABLE

PIN	DESCRIPTION	ACTION
1	12V SUPPLY	12V SUPPLY - CURRENT LIMITED
2	12V LATCH	WHEN 12V ATTACHED, DEVICE WILL GO OUT TO PRESET POSITION. WHEN 12V REMOVED, DEVICE WILL GO IN.
3	GROUND	GROUND
4		
5	DEVICE LATCH	SHORT TO GROUND (PIN 3), DEVICE WILL GO OUT TO PRESET POSITION, REMOVE SHORT DEVICE WILL GO IN.
6	DEVICE STOP	MOMENTARY SHORT TO GROUND (PIN 3), STOPS DEVICE IN CURRENT POSITION.
7	DEVICE OUT	MOMENTARY SHORT TO GROUND (PIN 3), MAKES DEVICE GO OUT.
8	DEVICE IN	MOMENTARY SHORT TO GROUND (PIN 3), MAKES DEVICE GO IN.

WIRE/CABLE TYPE		LED INDICATOR
568A	568B	
W G	W O	
G	O	
W O	W G	
B	B	
W B	W B	LED 4
O	G	LED 3
W BR	W BR	LED 2
BR	BR	LED 1

# RS232 CONTROL

This Mechanism can be controlled via RS232, utilising a 6 Pin RJ11/RJ25 connector OR 9 Pin Serial connector attached to a length of 6 core cable.

The mechanism's functions can be controlled by plugging this into the RJ11/RJ25 port on the mechanism control box, then inputting the RS232 commands shown in the RS232 Input Table below.

Confirmation of Contact Closure input will be shown by a single flash of the large green LED located on the end of the control box.

## RJ11/RJ25 PIN LAYOUT

**PIN 1: RX**  
**PIN 6: TX**  
**PIN 3 & 4: GROUND**

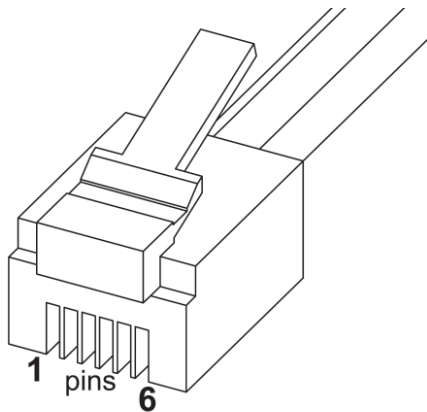

## SERIAL PIN LAYOUT

**PIN 2: RX**  
**PIN 3: TX**  
**PIN 5: GROUND**

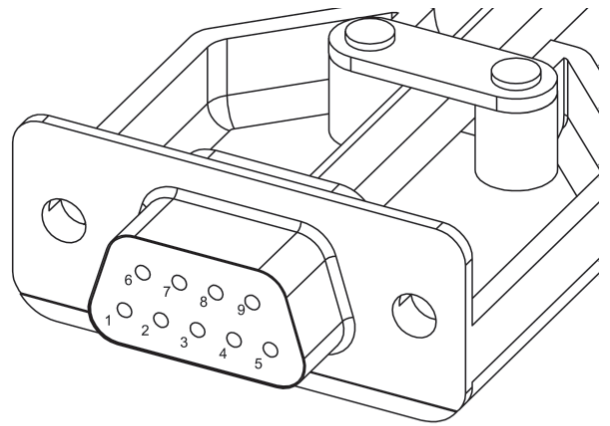

## RS232 PROGRAMMING DETAILS

Baud Rate: 9600

Stop Bit: 1

Parity: None

Databits: 8

RJ11/RJ25	Func.	9 PIN Serial	Colour
PIN 1	TX-RX	PIN 2	Blue
PIN 3	GROUND	PIN 5	Green
PIN 4	GROUND	PIN 5	Red
PIN 6	RX-TX	PIN 3	White

## RS232 INPUT TABLE

**IMPORTANT - Ensure all protocols are entered exactly as written below, including Carriage Return (ENTER / ASCII 13)**

Protocol	Action
fa_in Carriage Return (Enter / ASCII 13)	Device IN
fa_out Carriage Return (Enter / ASCII 13)	Device OUT
fa_stop Carriage Return (Enter / ASCII 13)	Device STOP (At any position)

# SCREEN CONTROL

The control box for the PD Projector Lift mechanism's has the ability to power a 240v/110v projection screen, enabling the projection screen and Projector Lift to open/close at the same time.

The control board also has the ability to delay the closing of the Projector Drop mechanism for 3 minutes after issuing the IN command, to allow the projector inside to cool after operation.

A wiring layout for the control board is shown below with details on how to perform the above functions;

## DC1

A low voltage connection for the up stop switch in the mechanism. This must be re-connected if you extend the cables. When the up switch is hit, the connection between CC1 and ground is broken, the LED goes off and the projector drop stops going up.

Link CC3 to 0V to delay the projector carriage going in by 3 mins, allowing the projector to cool.

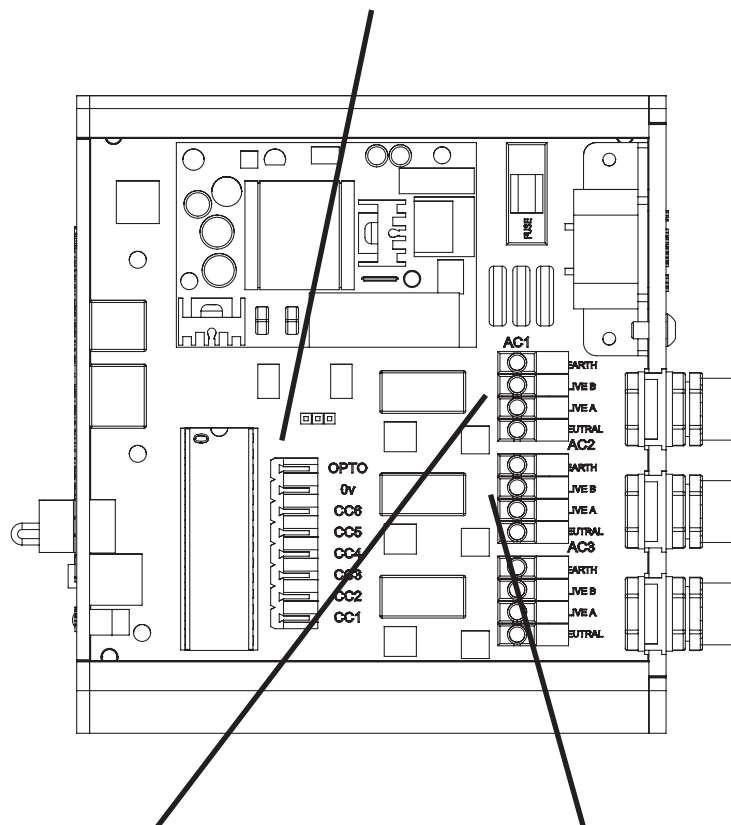

**AC1**  
Gives an output of 240V (or 110V) to control the Projector drop motor.

**AC2**  
Outputs stay live for 120 seconds after the OUT or IN functions are selected.



#### **EUROPEAN OFFICE**

**Address:**  
Unit 6-8  
Brunel Road  
Bedford  
Bedfordshire  
MK41 9TG

**Phone:** +44 (0) 1438 833577  
**Email:** [info@futureautomation.co.uk](mailto:info@futureautomation.co.uk)

**Office Hours:**  
Mon - Fri 8:00 to 17:30 GMT  
Saturday & Sunday - Closed

#### **NORTH AMERICAN OFFICE**

**Address:**  
Enterprise Park  
127 Venture Drive  
Dover  
NH  
03820

**Phone:** +1 (603) 742 9181  
**Email:** [info@futureautomation.net](mailto:info@futureautomation.net)

**Office Hours:**  
Mon - Fri 7:00 to 17:00 EST  
Saturday & Sunday - Closed