

I-LSM-S-BE-6

INVERTED LIFT & SWIVEL FOR BOX ENCLOSURE

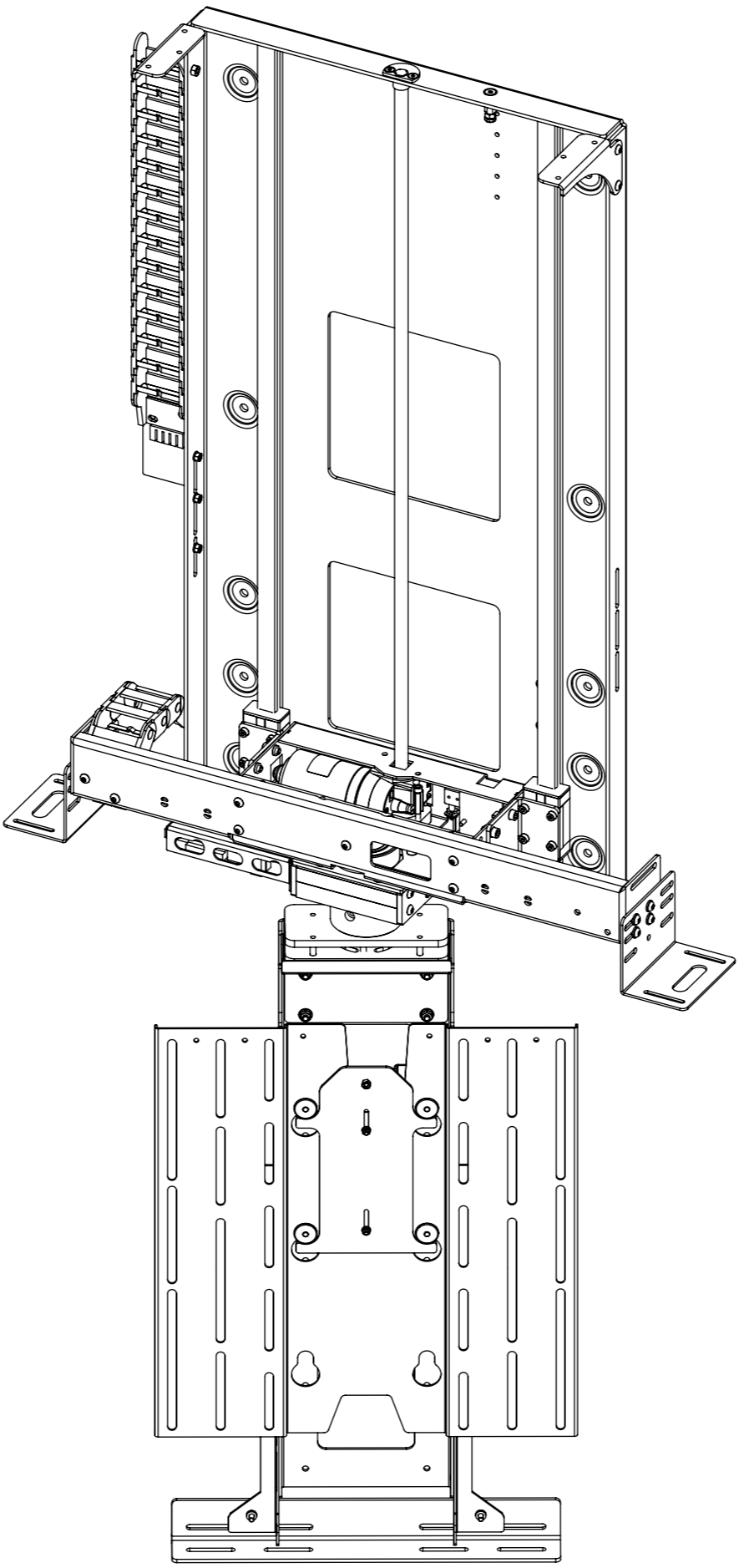

future automation



I-LSM-S-BE-6

INVERTED LIFT & SWIVEL FOR BOX ENCLOSURE



SPECIFICATION	MEASUREMENTS
Maximum Screen Height	730mm (28 3/4")
Maximum Rotation	180 ° in each direction
Maximum Lifting Capacity	50Kg (110lb)
Maximum Lifting Capacity (Marine)	30Kg (66lb)
Internal Cabinet Height	950mm (37 3/8")
Decibel Rating	57 dB
Packaging Dimensions	1150 x 850 x 330mm (45 1/4 x 33 7/16 x 13")
Shipping Weight	40Kg (88lb)
Movement Type	Motorised
Power Supply Required	110V - 240V AC
Power Consumption	250 - 500W
Power Consumption Standby	3W
Mounting Patterns Supported	VESA 400, 300, 200 W x 400, 300, 200 H
Control Options	IR Remote, RS232, Contact Closure, RF Available
Product Options / Features	Specific B&O and Loewe mounts / adapters, Custom RAL paint finishes
Package Contents	Mechanism, IR remote control
Marine Suitable	Yes

I-LSM-S-BE-6

INVERTED LIFT & SWIVEL FOR BOX ENCLOSURE



CABLE ROUTING

The LSM has an easily removable Mount Cover that cables from the screen can be routed underneath. Cables then travel through the centre of the Mount Boss and into the beam. Cables must be routed carefully to prevent any interference with the LSM beam as it operates.

Screen and Mechanism cables should be routed to a control box outside of the cabinet via an opening in the back of the cabinet or a conduit leading to the bottom.

- SCREEN CABLES
- MECHANISM CABLES
- POWER CABLE

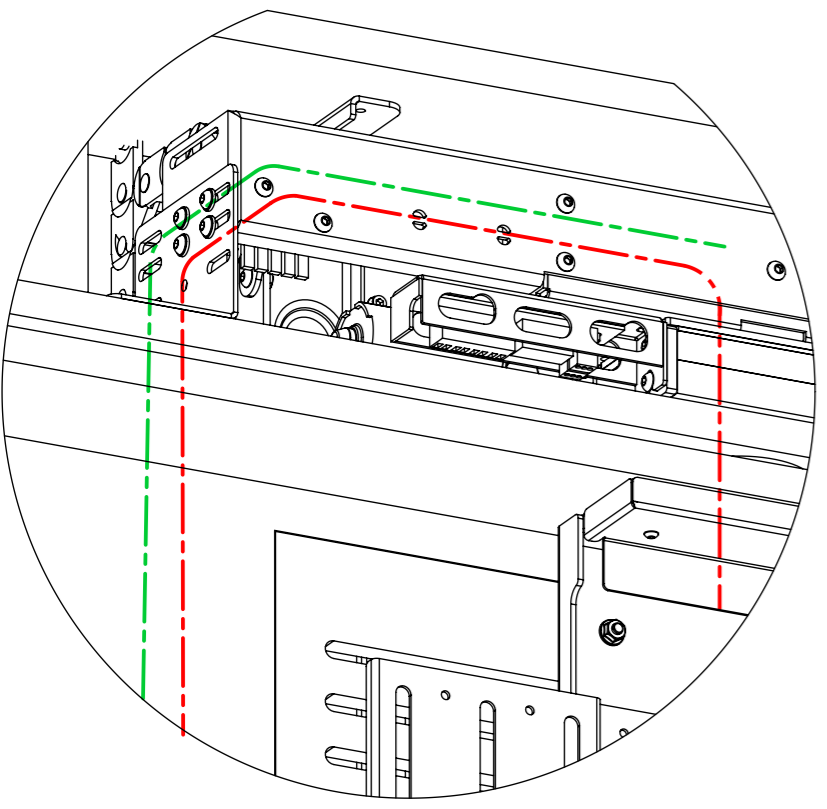

DETAIL A

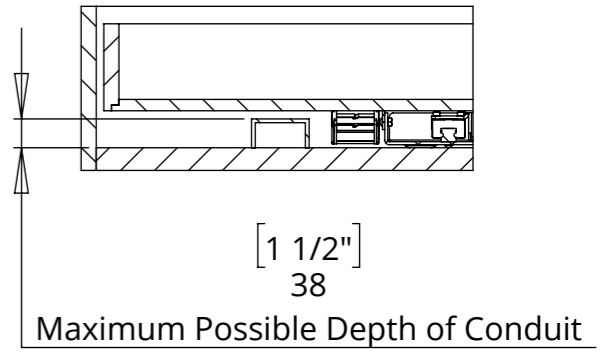
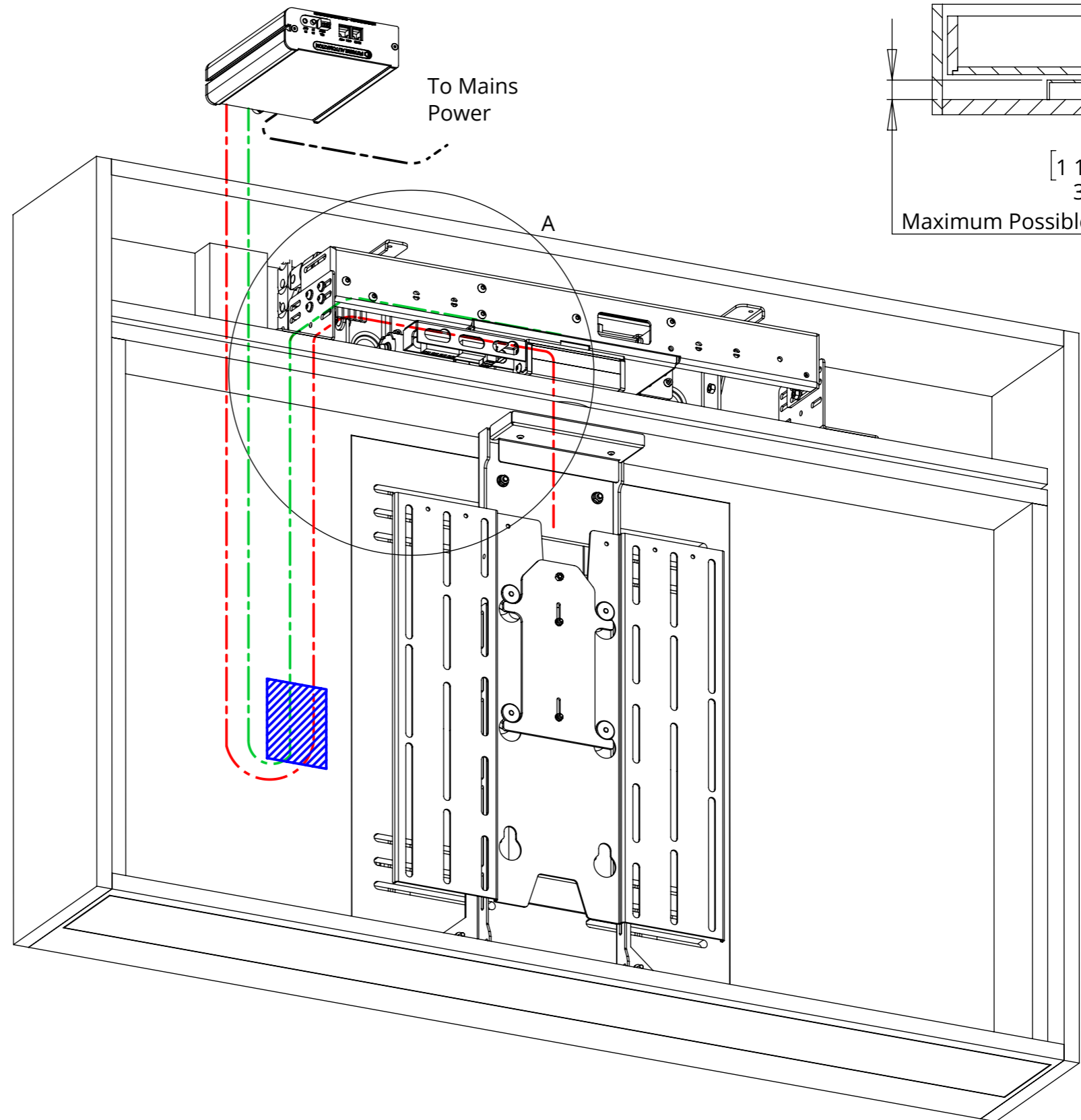

I-LSM-S-BE-6



future automation

INVERTED LIFT & SWIVEL FOR BOX ENCLOSURE

MECHANISM DOWN - IN CABINET

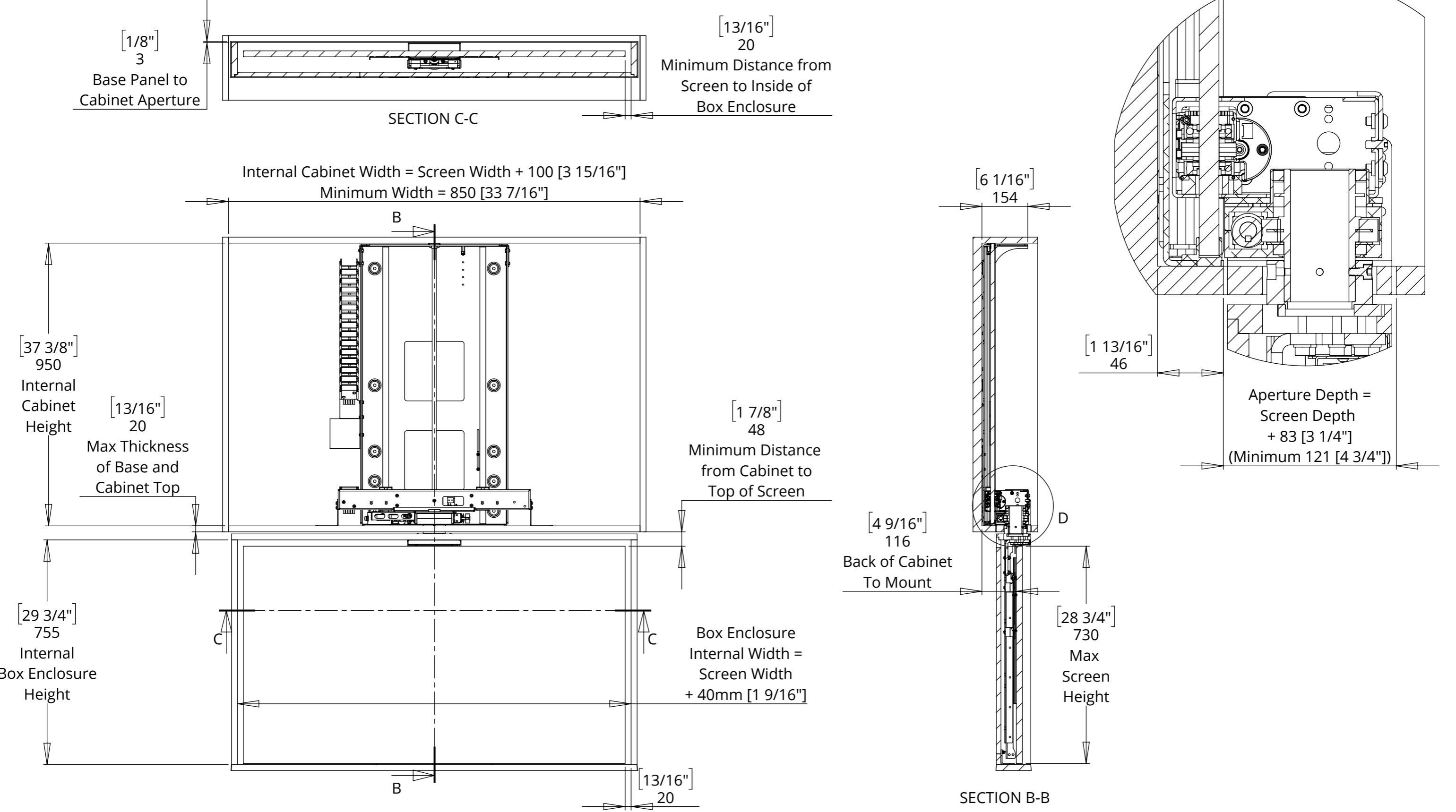

I-LSM-S-BE-6

INVERTED LIFT & SWIVEL FOR BOX ENCLOSURE



future automation

MECHANISM UP - IN CABINET

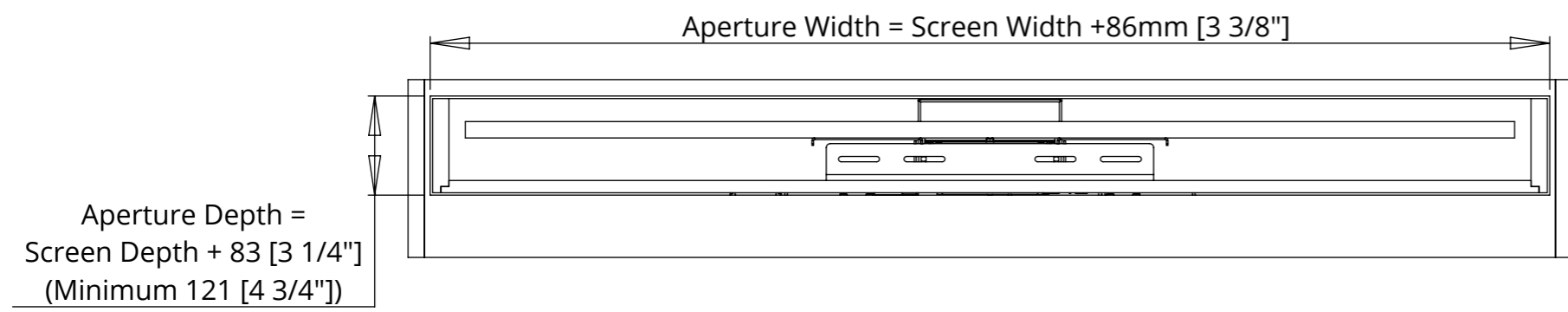

Shown with tapered Box Enclosure Lid in square Cabinet Aperture.

A tapered Cabinet Aperture can be used to improve the fit.

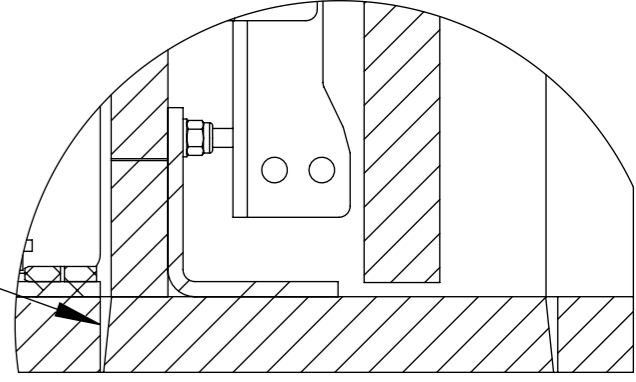

[4 9/16"]
116
Back of Cabinet
to Mount

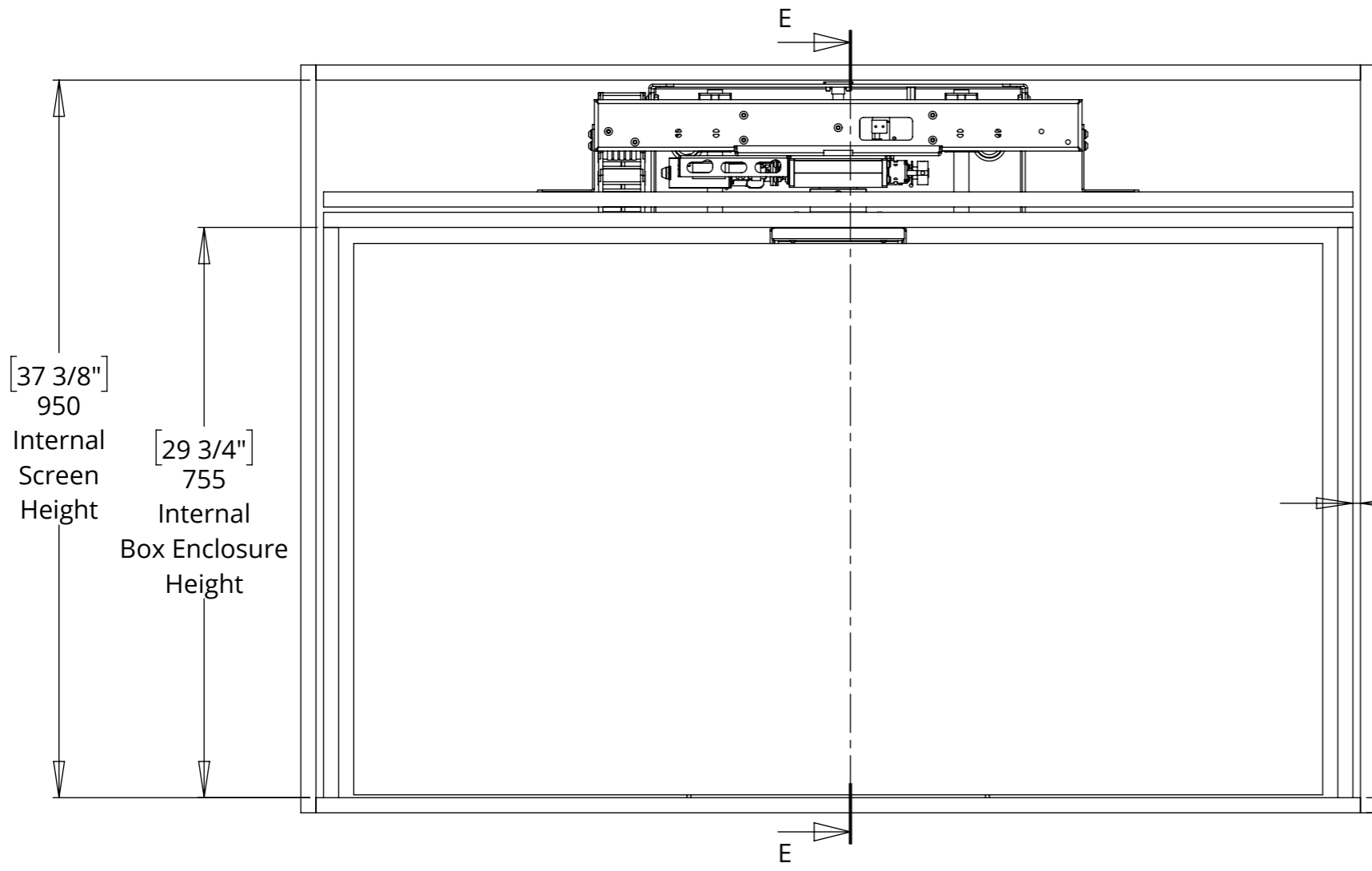

[3/8"]
10
Minimum Distance
between Box Enclosure
and Cabinet

[13/16"]
20
Maximum
Thickness
of Base and
Cabinet Top

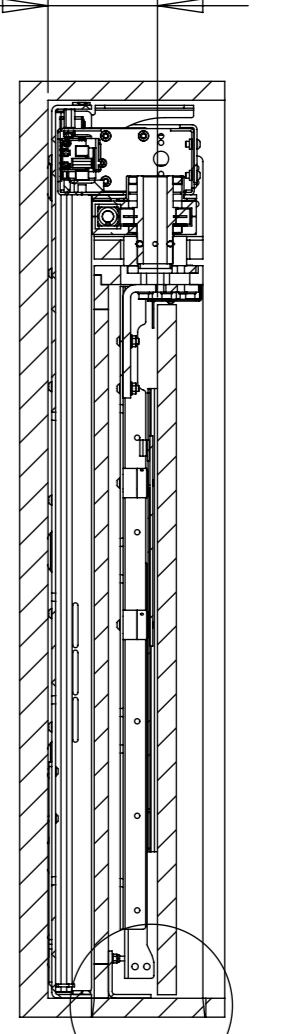

I-LSM-S-BE-6



INVERTED LIFT & SWIVEL FOR BOX ENCLOSURE

BASE PANEL AND BOX ENCLOSURE LID DETAILS

NOTE: A tapered Box Enclosure Lid creates a good fit in the Cabinet Aperture and helps the Box Enclosure to locate within the cabinet.

BOX ENCLOSURE LID (TAPERED) - TOP VIEW

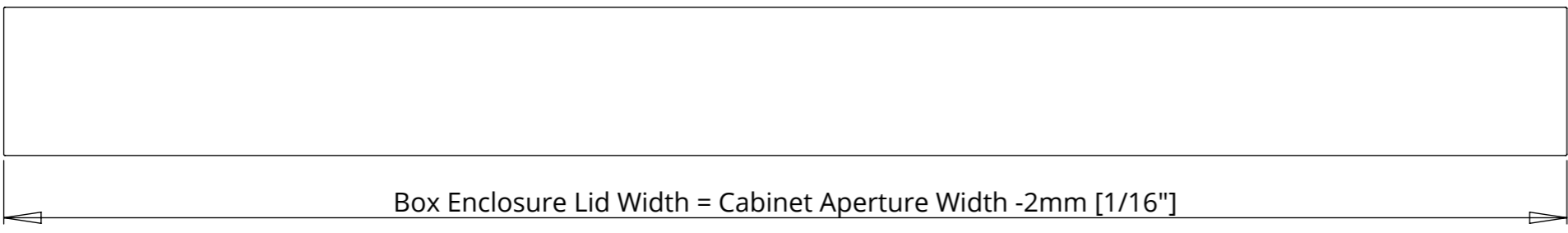

BASE PANEL - TOP VIEW

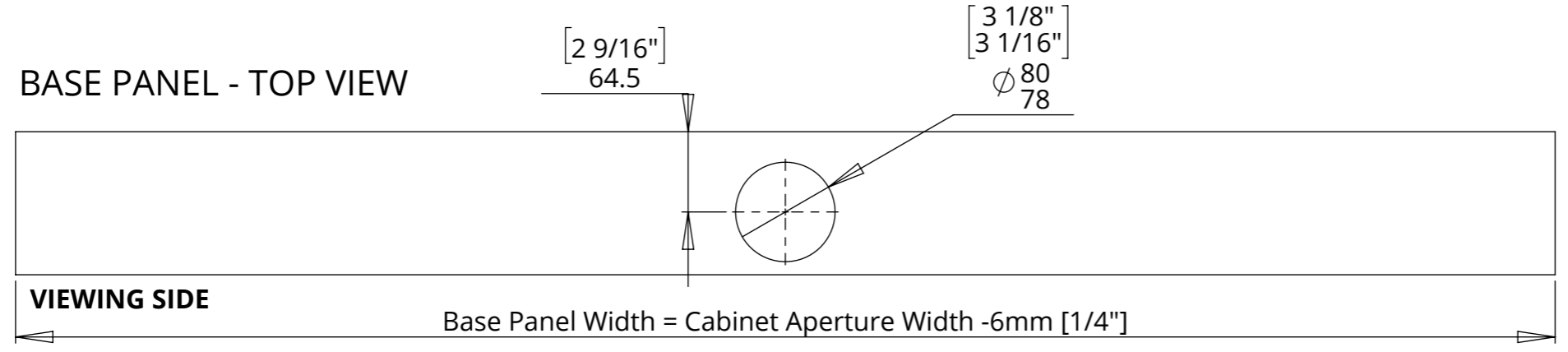

BOX ENCLOSURE BASE PANEL - TOP VIEW

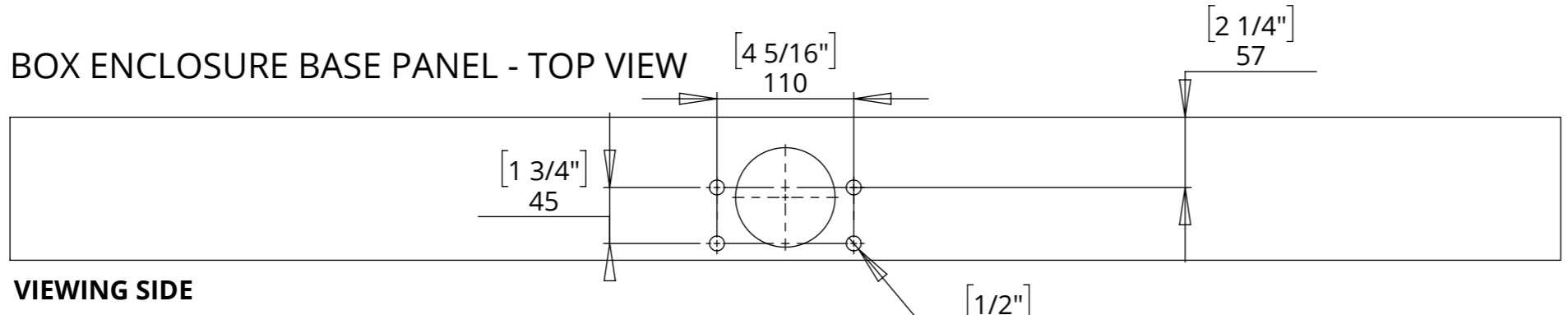

BOX ENCLOSURE BASE PANEL - BOTTOM VIEW

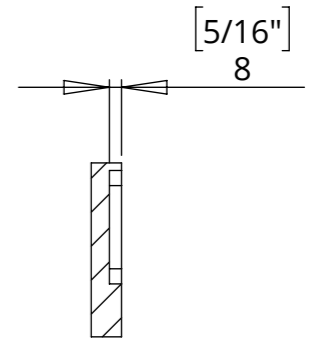
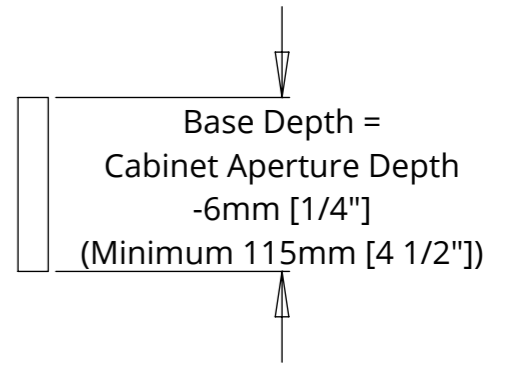
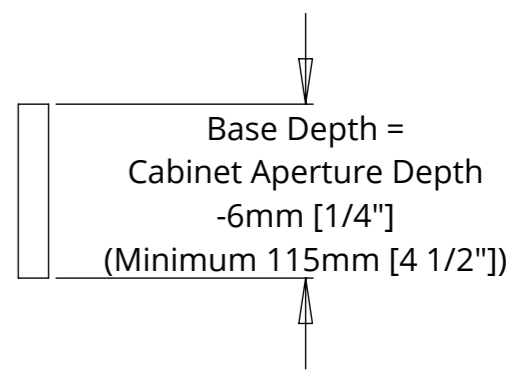
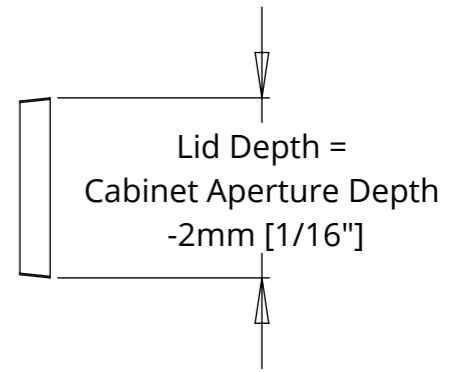
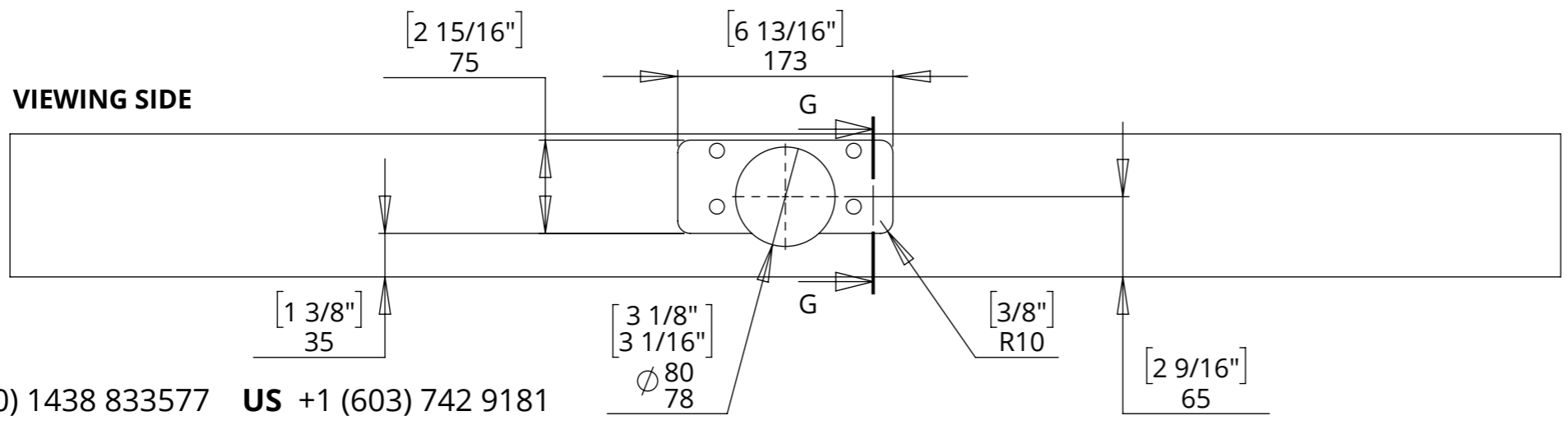

SECTION G-G

TECHNICAL SHEET

I-LSM-S-BE-6

INVERTED LIFT & SWIVEL FOR BOX ENCLOSURE

BOX ENCLOSURE POSITION ADJUSTMENT

The countersink bolts enable fine tuning the position of the box enclosure relative to the uprights

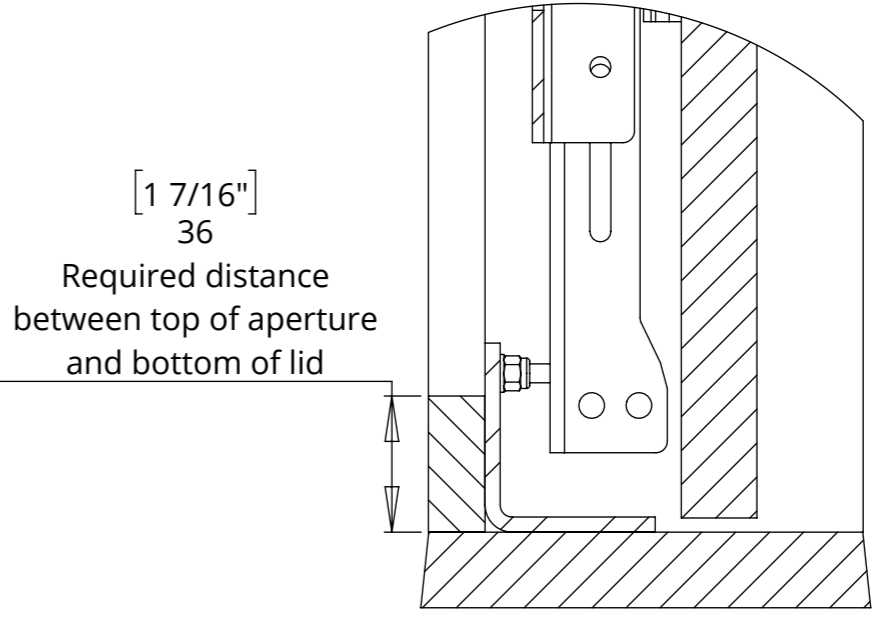
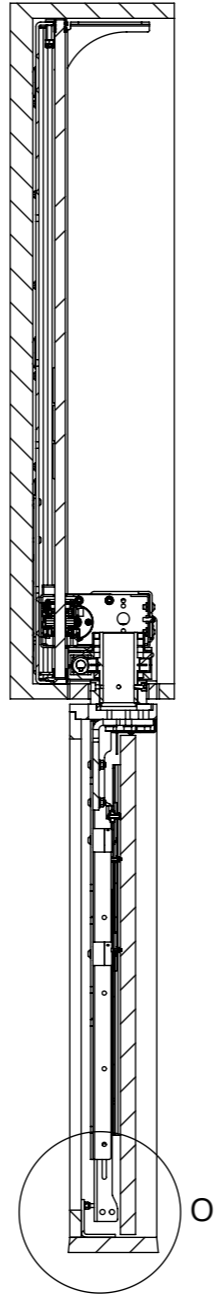
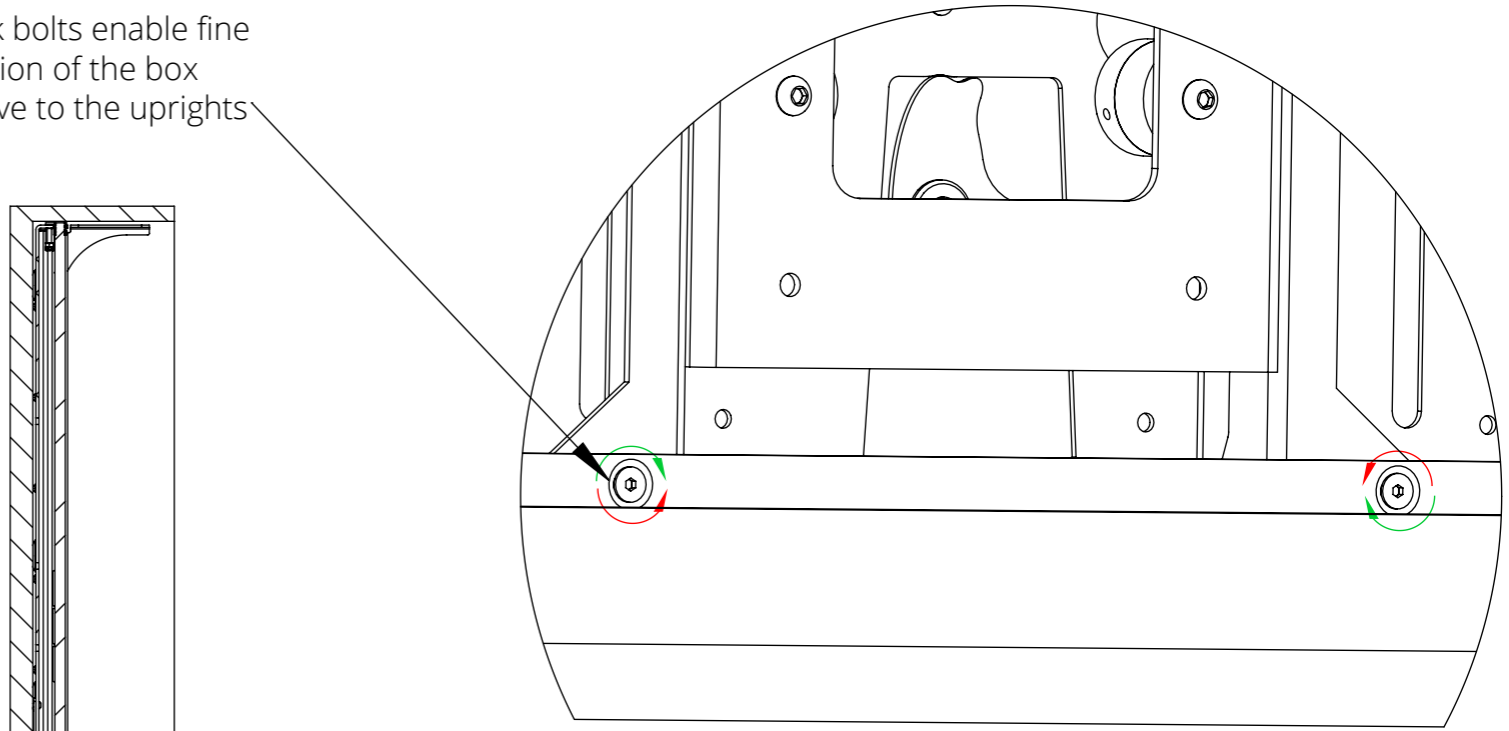
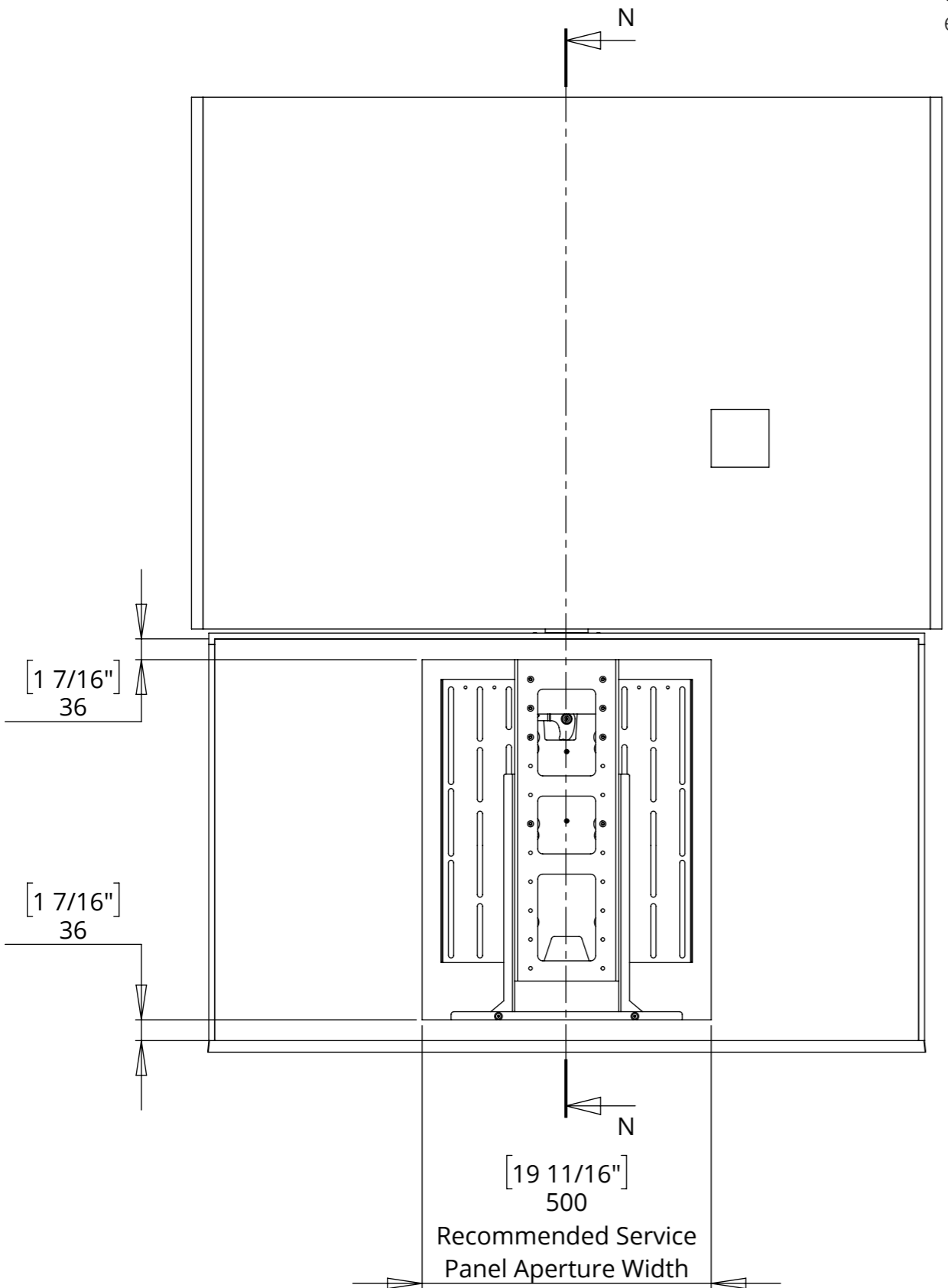

DETAIL O

I-LSM-S-BE-6

INVERTED LIFT & SWIVEL FOR BOX ENCLOSURE



future automation

SCREEN MOUNT ADJUSTABILITY

A standard adjustable height VESA 400 mount is included. This is also compatible with VESA 300 and 200 mounting patterns

Separate VESA 300 and 200 mounts are available.

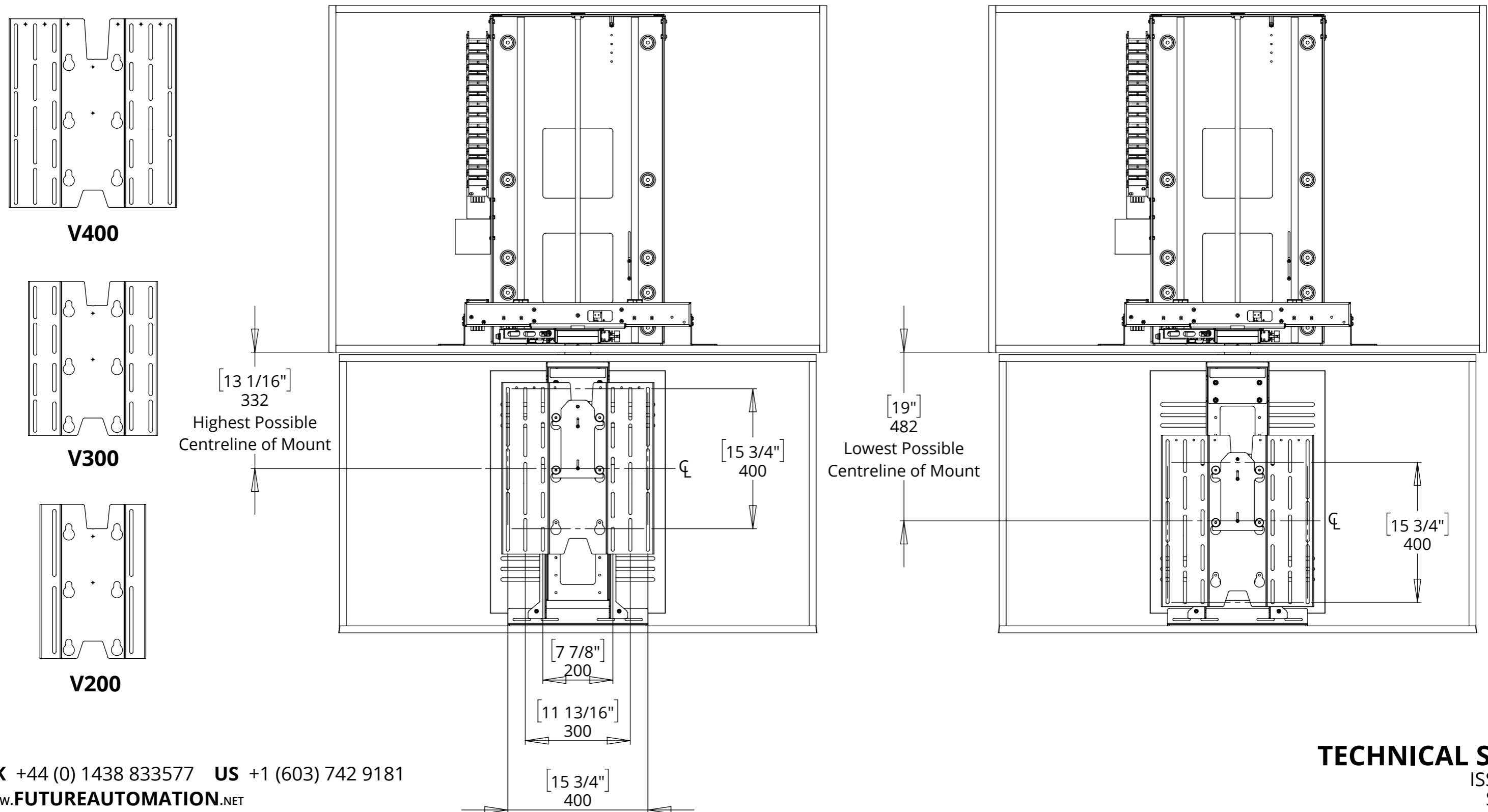

I-LSM-S-BE-6

INVERTED LIFT & SWIVEL FOR BOX ENCLOSURE



MECHANISM INSTALLATION OVERVIEW

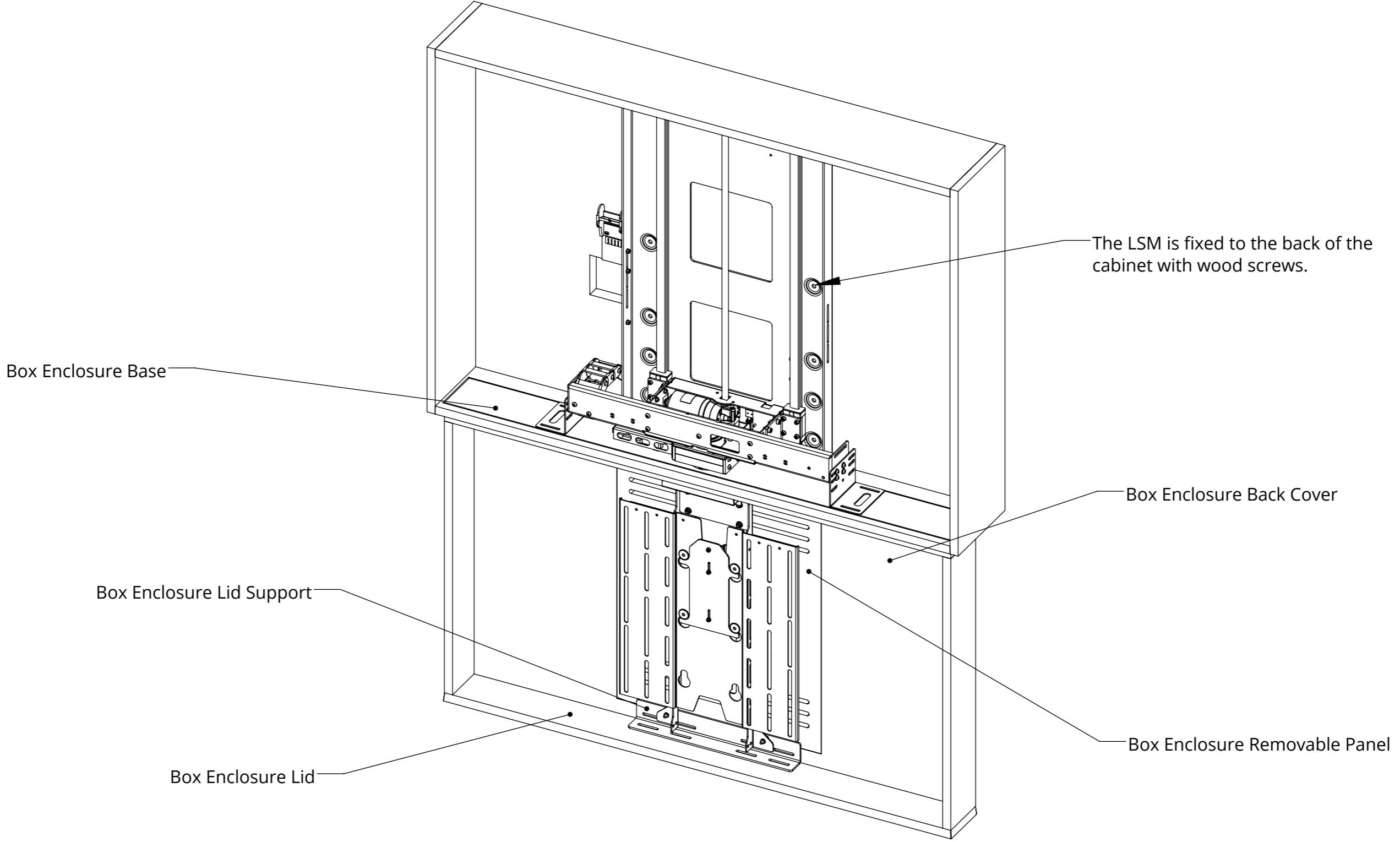

I-LSM-S-BE-6

INVERTED LIFT & SWIVEL FOR BOX ENCLOSURE



future automation

OVERALL MECHANISM DIMENSIONS

MECHANISM - DOWN POSITION

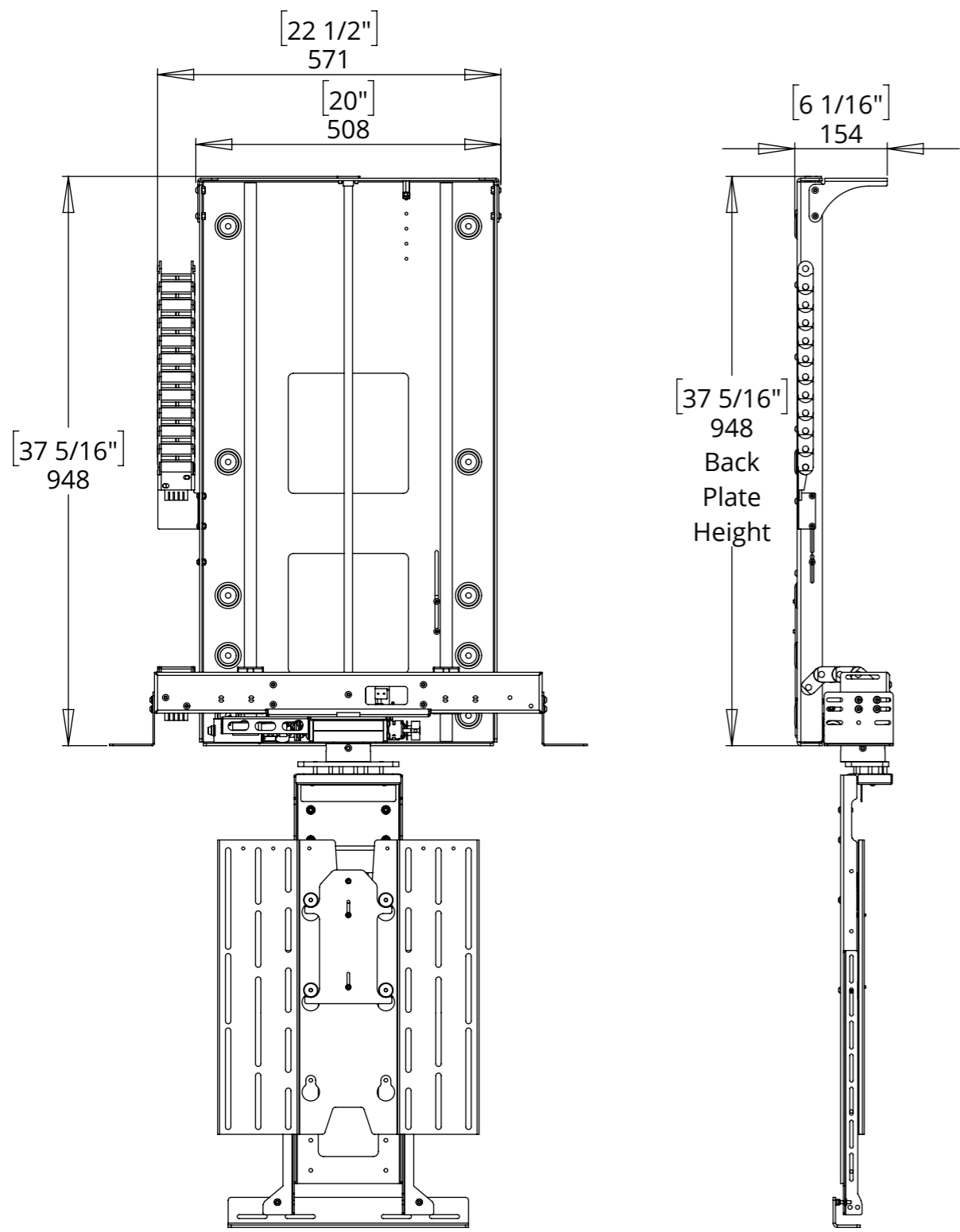

MECHANISM - UP POSITION

