

I-LSM-BE 5

INVERTED LIFT SYSTEM FOR BOX ENCLOSURE

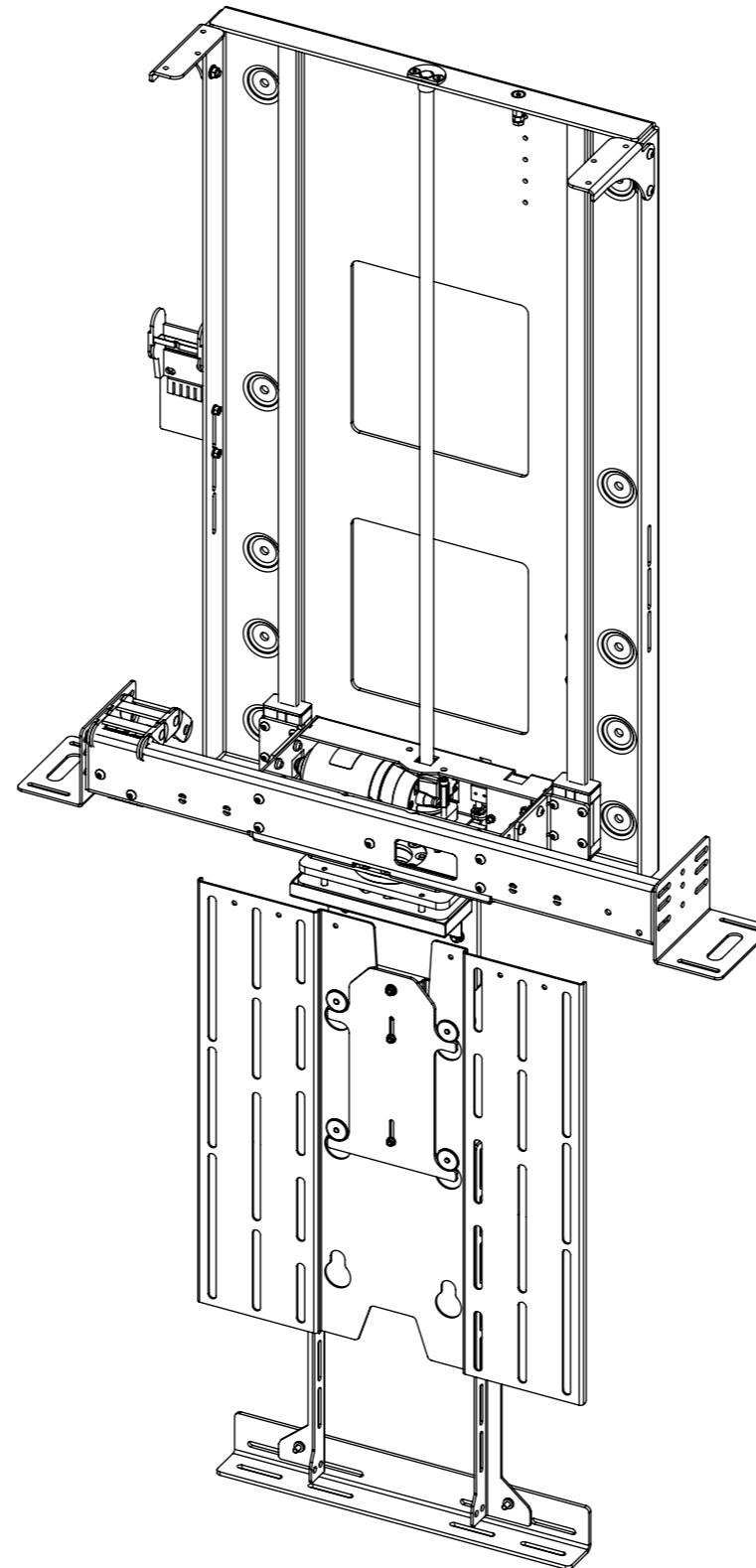

future automation



I-LSM-BE 5

INVERTED LIFT SYSTEM FOR BOX ENCLOSURE



future automation

SPECIFICATION	MEASUREMENTS
Maximum Screen Height	725mm (28 9/16")
Maximum Lifting Capacity	50Kg (110lb)
Maximum Lifting Capacity (Marine)	30Kg (66lb)
Internal Cabinet Height	880mm (34 5/8")
Decibel Rating	52 dB
Packaging Dimensions	1080 x 850 x 330mm (42 1/2 x 33 7/16 x 13")
Shipping Weight	34Kg (75lb)
Movement Type	Motorised
Power Supply Required	110V - 240V AC
Power Consumption	250 - 500W
Power Consumption Standby	3W
Mounting Patterns Supported	VESA 400, 300, 200 W x 400, 300, 200 H
Control Options	IR Remote, RS232, Contact Closure, RF Available
Product Options / Features	Specific B&O and Loewe mounts / adapters, Custom RAL paint finishes
Package Contents	Mechanism, IR remote control
Marine Suitable	Yes

I-LSM-BE 5

INVERTED LIFT SYSTEM FOR BOX ENCLOSURE



CABLE ROUTING

The LSM has an easily removable Mount Cover that cables from the screen can be routed underneath. Cables then travel through the centre of the Mount Boss and into the beam. Cables must be routed carefully to prevent any interference with the LSM beam as it operates.

Screen and Mechanism cables should be routed to a control box outside of the cabinet via an opening in the back of the cabinet or a conduit leading to the bottom.

- - - - - SCREEN CABLES
- - - - - MECHANISM CABLES
- - - - - POWER CABLE

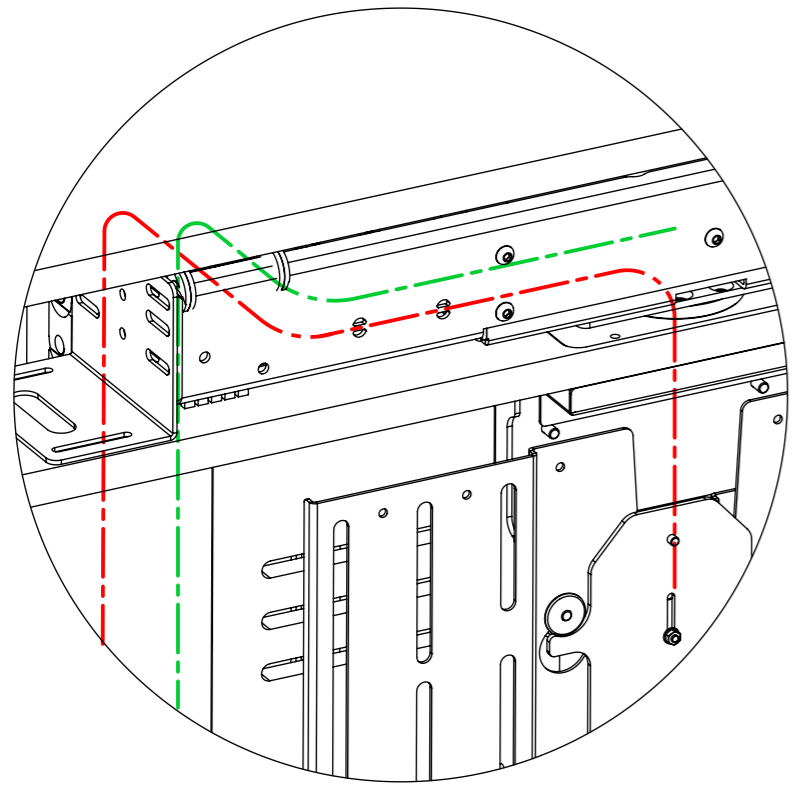

DETAIL A

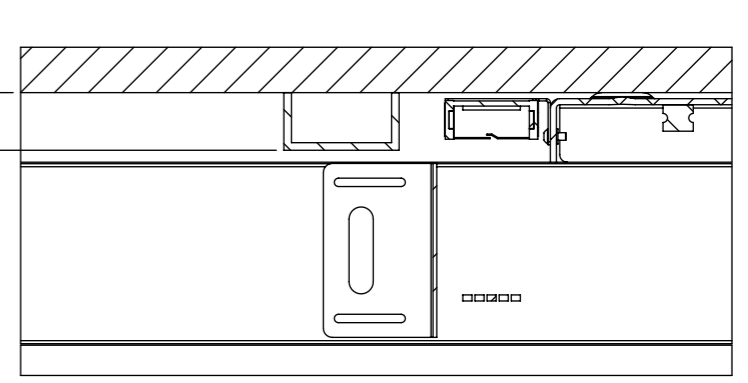
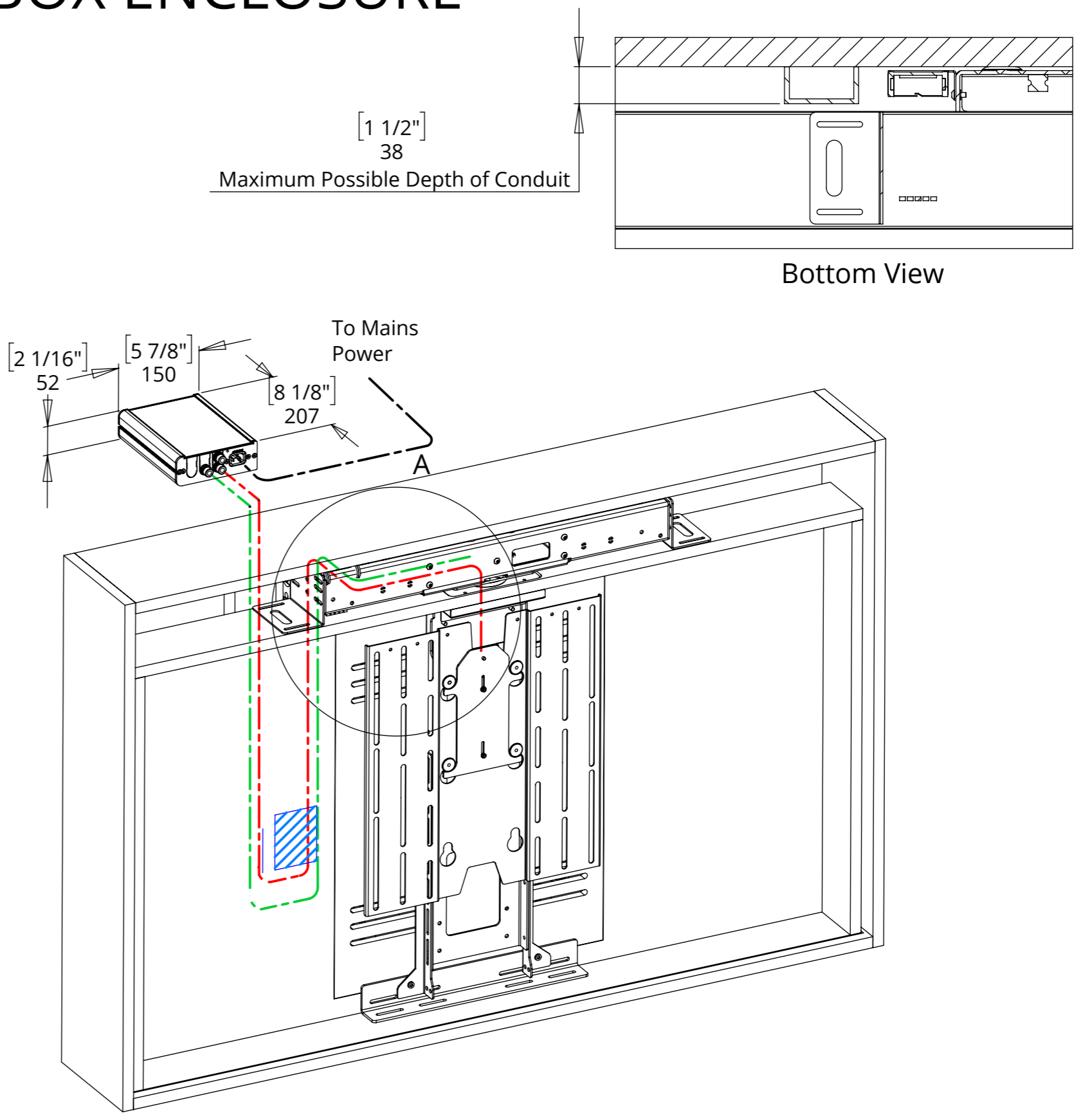

Bottom View

I-LSM-BE 5

INVERTED LIFT SYSTEM FOR BOX ENCLOSURE

MECHANISM DOWN - IN CABINET

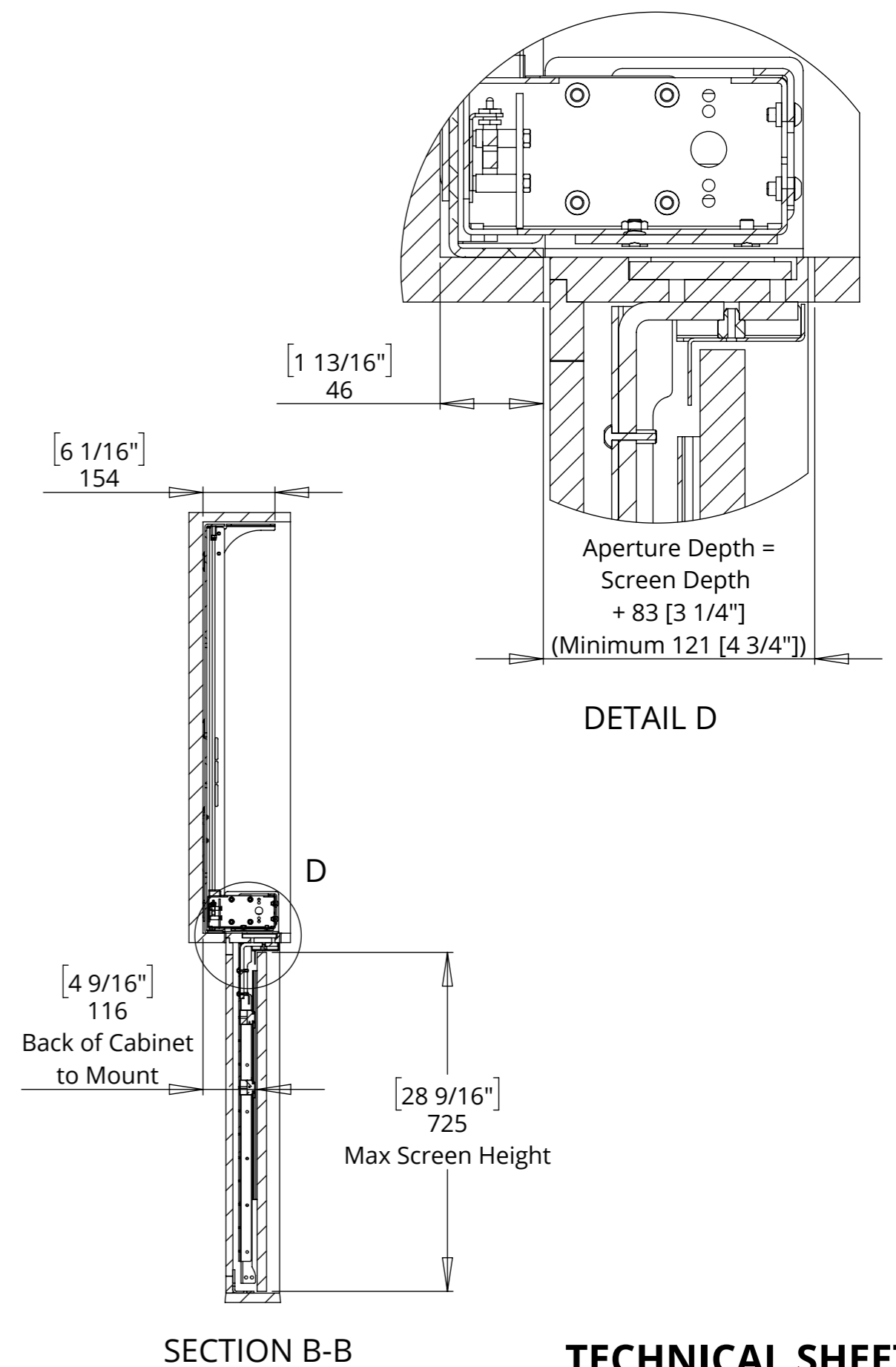
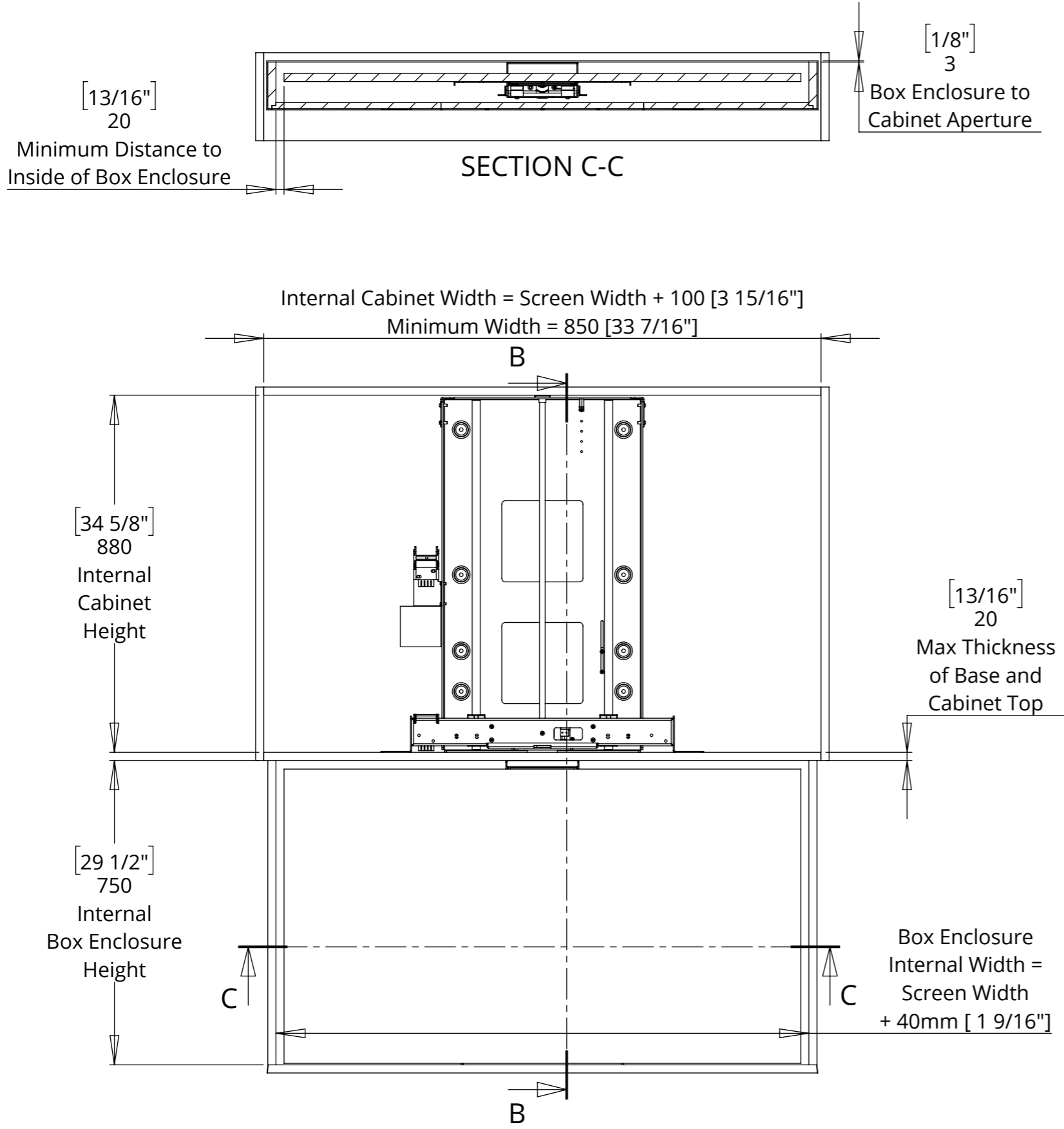

I-LSM-BE 5

INVERTED LIFT SYSTEM FOR BOX ENCLOSURE



future automation

MECHANISM UP - IN CABINET

Shown with tapered Box Enclosure Lid in square Cabinet Aperture.

A tapered Cabinet Aperture can be used to improve the fit.

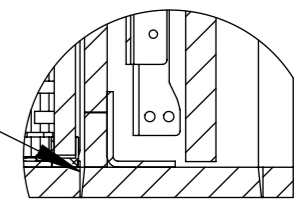

DETAIL F

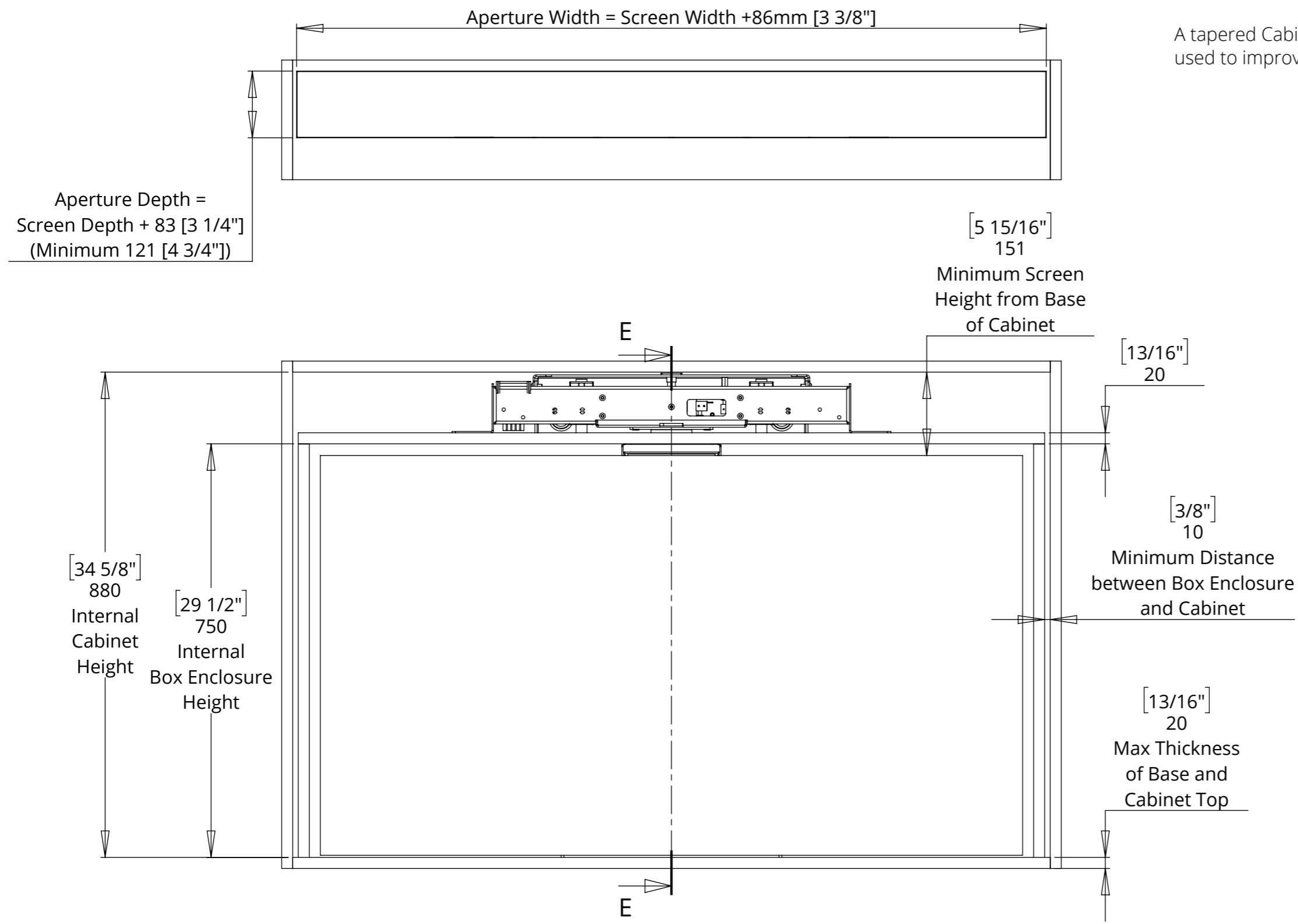

[4 9/16"] 116
Back of Cabinet to Mount

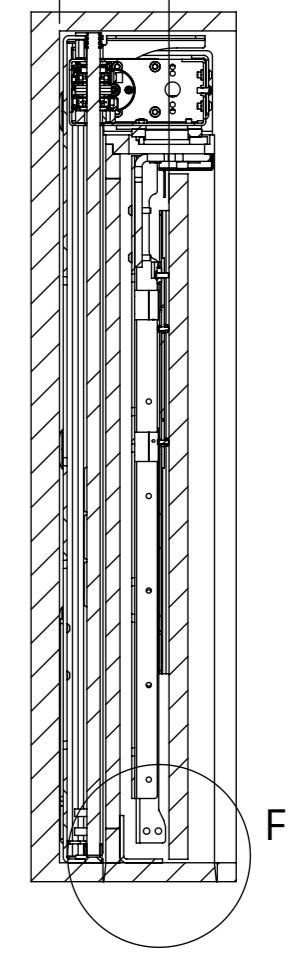

SECTION E-E

I-LSM-BE 5

INVERTED LIFT SYSTEM FOR BOX ENCLOSURE



future automation

BASE PANEL AND BOX ENCLOSURE LID DETAILS

NOTE: A tapered Box Enclosure Lid creates a good fit in the Cabinet Aperture and helps the Box Enclosure to locate within the cabinet.

BOX ENCLOSURE LID (TAPERED) - TOP VIEW

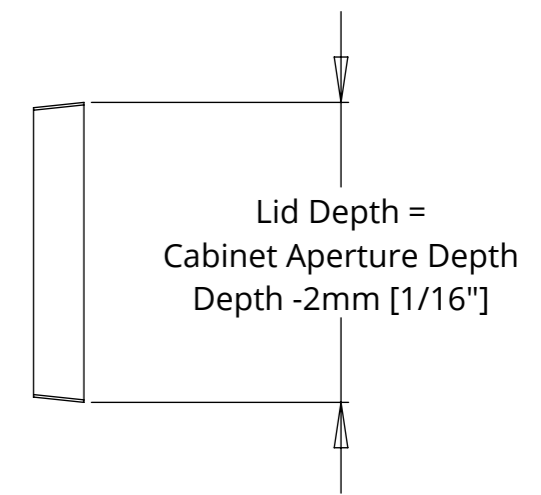
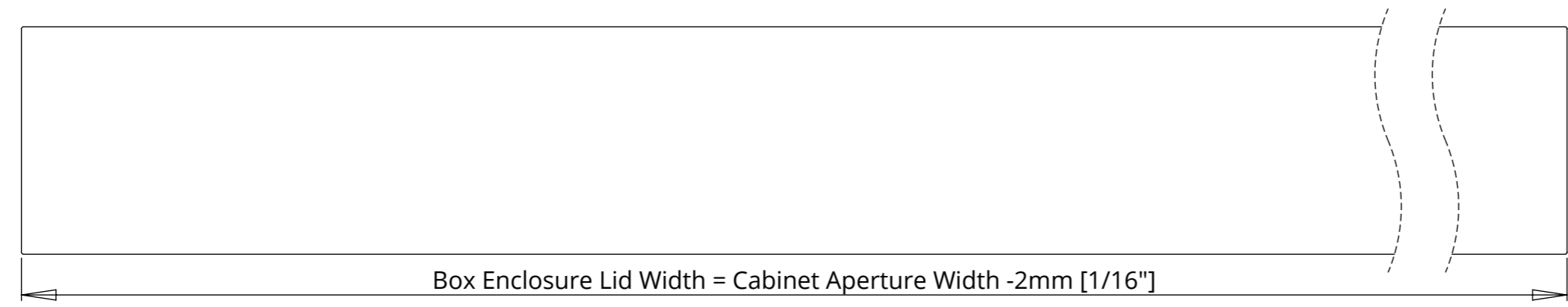

BASE PANEL - TOP VIEW

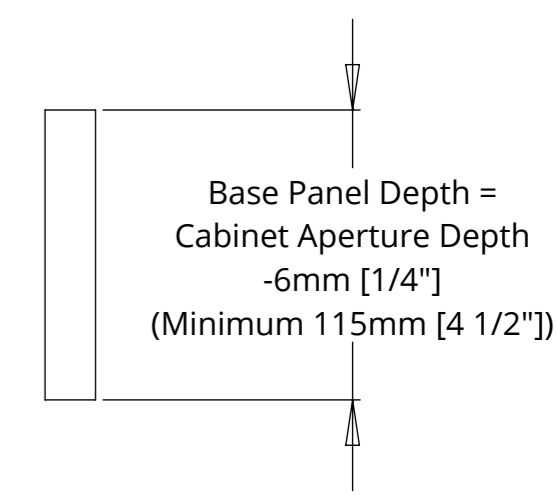
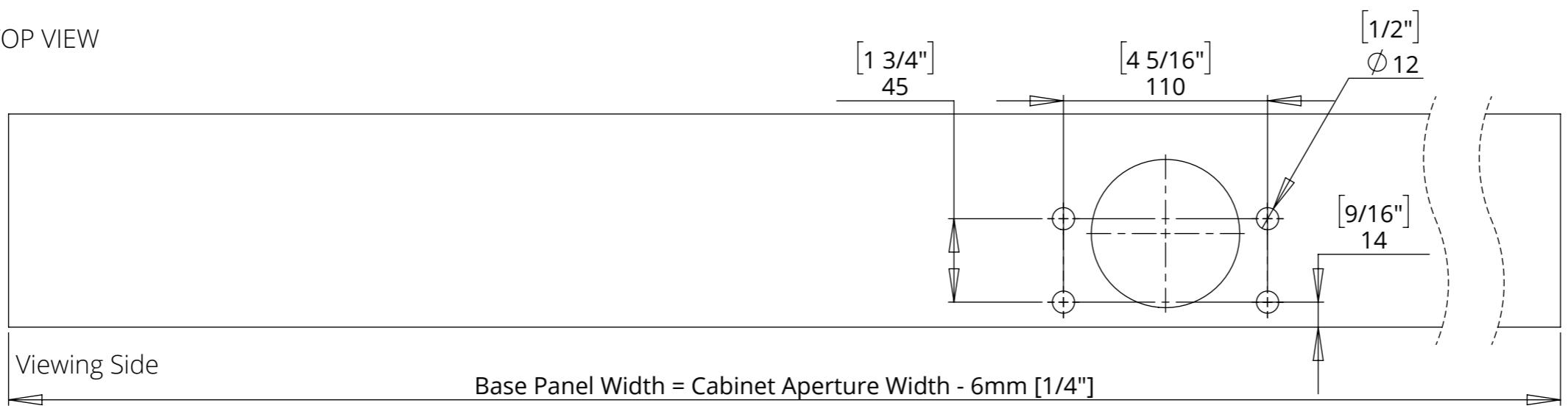

BASE PANEL - BOTTOM VIEW

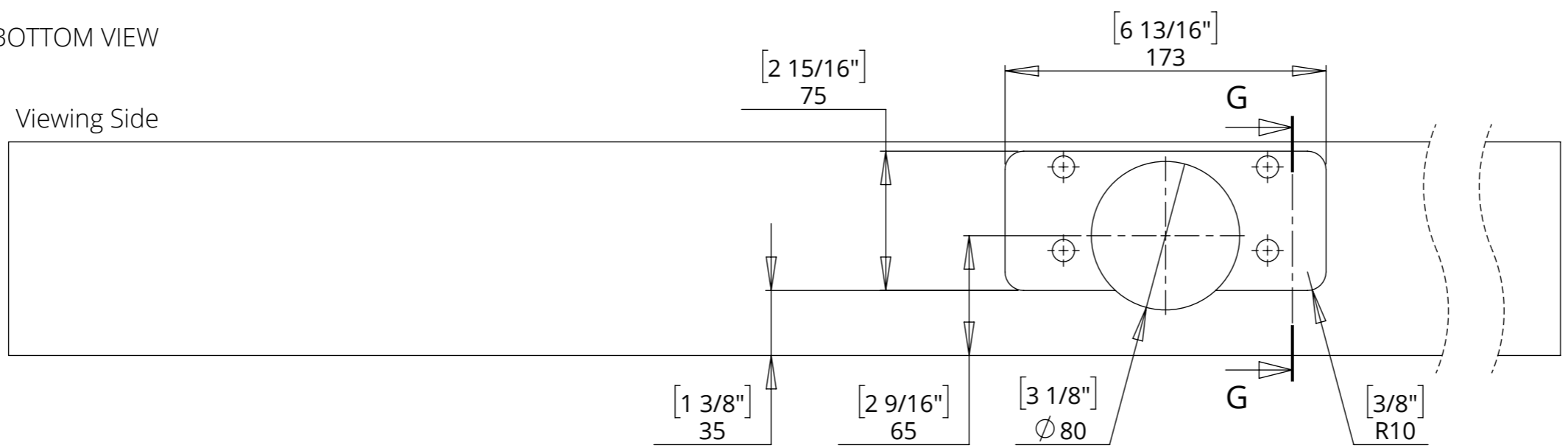

SECTION G-G

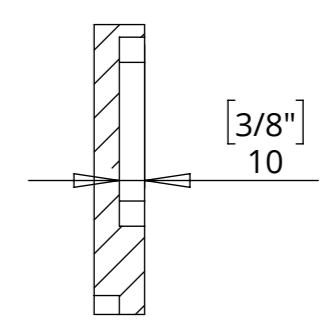

I-LSM-BE 5

INVERTED LIFT SYSTEM FOR BOX ENCLOSURE

BOX ENCLOSURE POSITION ADJUSTMENT

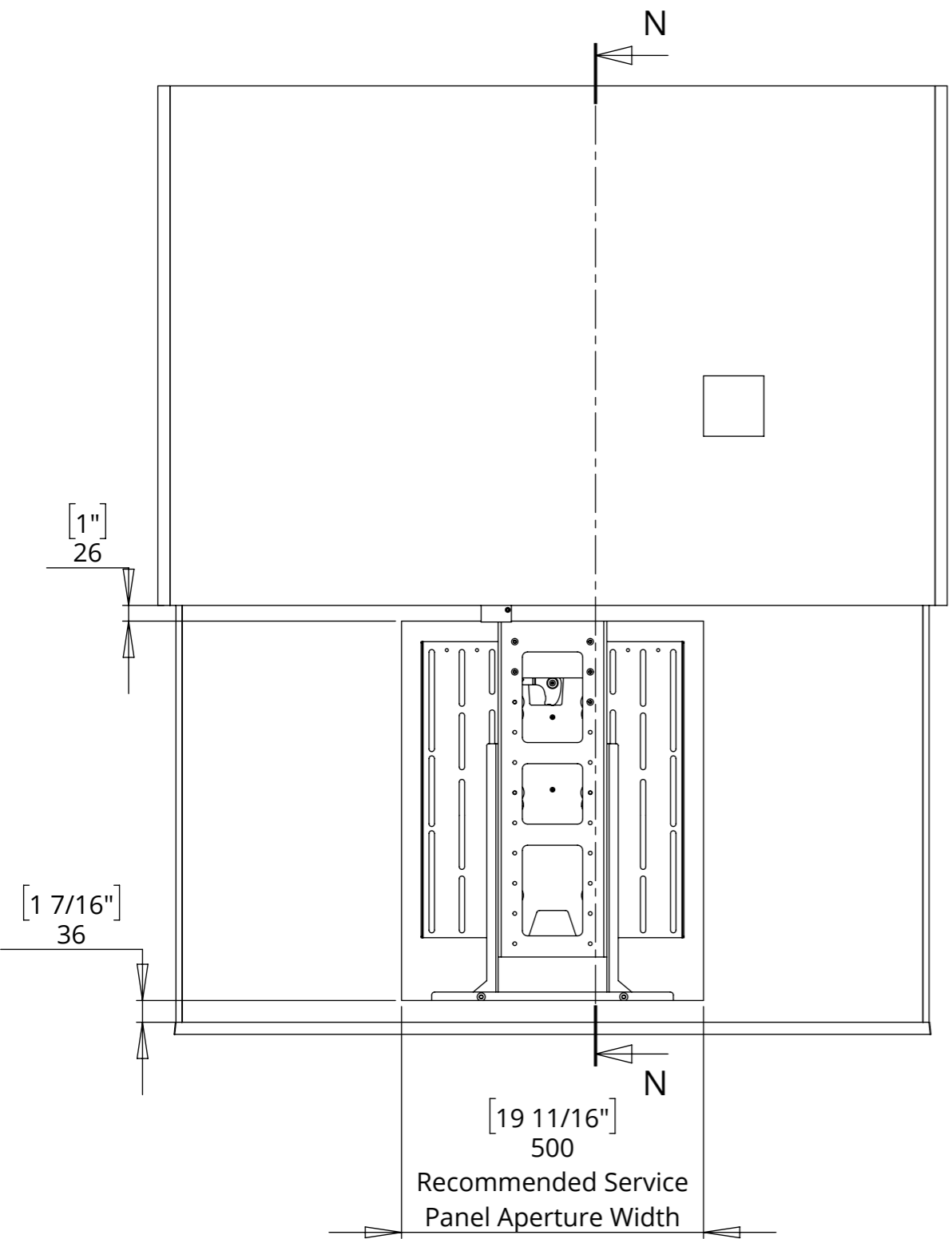

The countersink bolts enable fine tuning the position of the box enclosure relative to the uprights

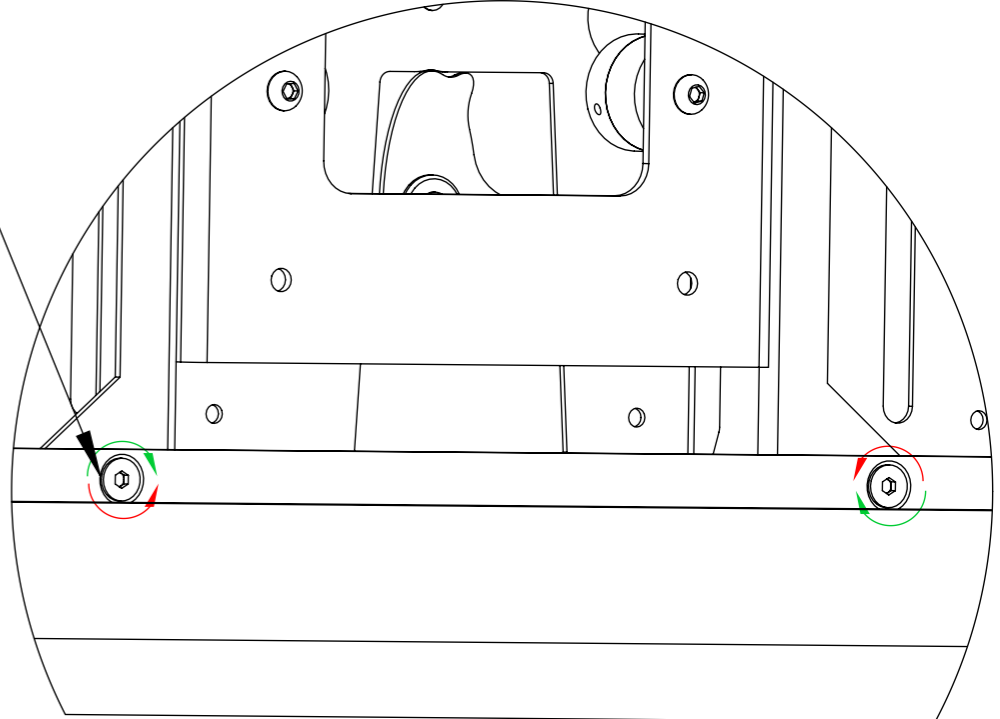
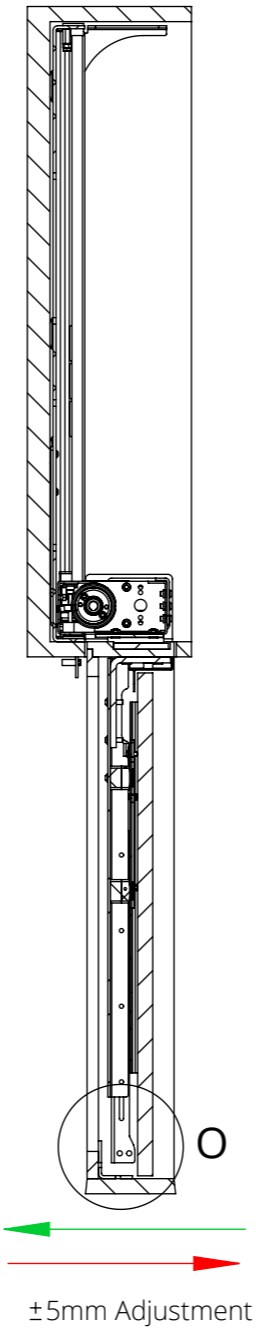

$1\frac{7}{16}$ " (36)
Required distance between top of aperture and bottom of lid

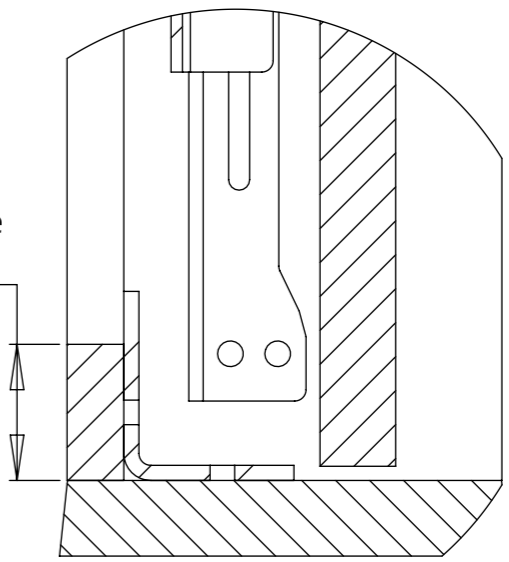

DETAIL O

SECTION N-N

I-LSM-BE 5

INVERTED LIFT SYSTEM FOR BOX ENCLOSURE



future automation

SCREEN MOUNT ADJUSTABILITY

A standard adjustable height VESA 400 mount is included. This is also compatible with VESA 300 and 200 mounting patterns

Separate VESA 300 and 200 mounts are available.

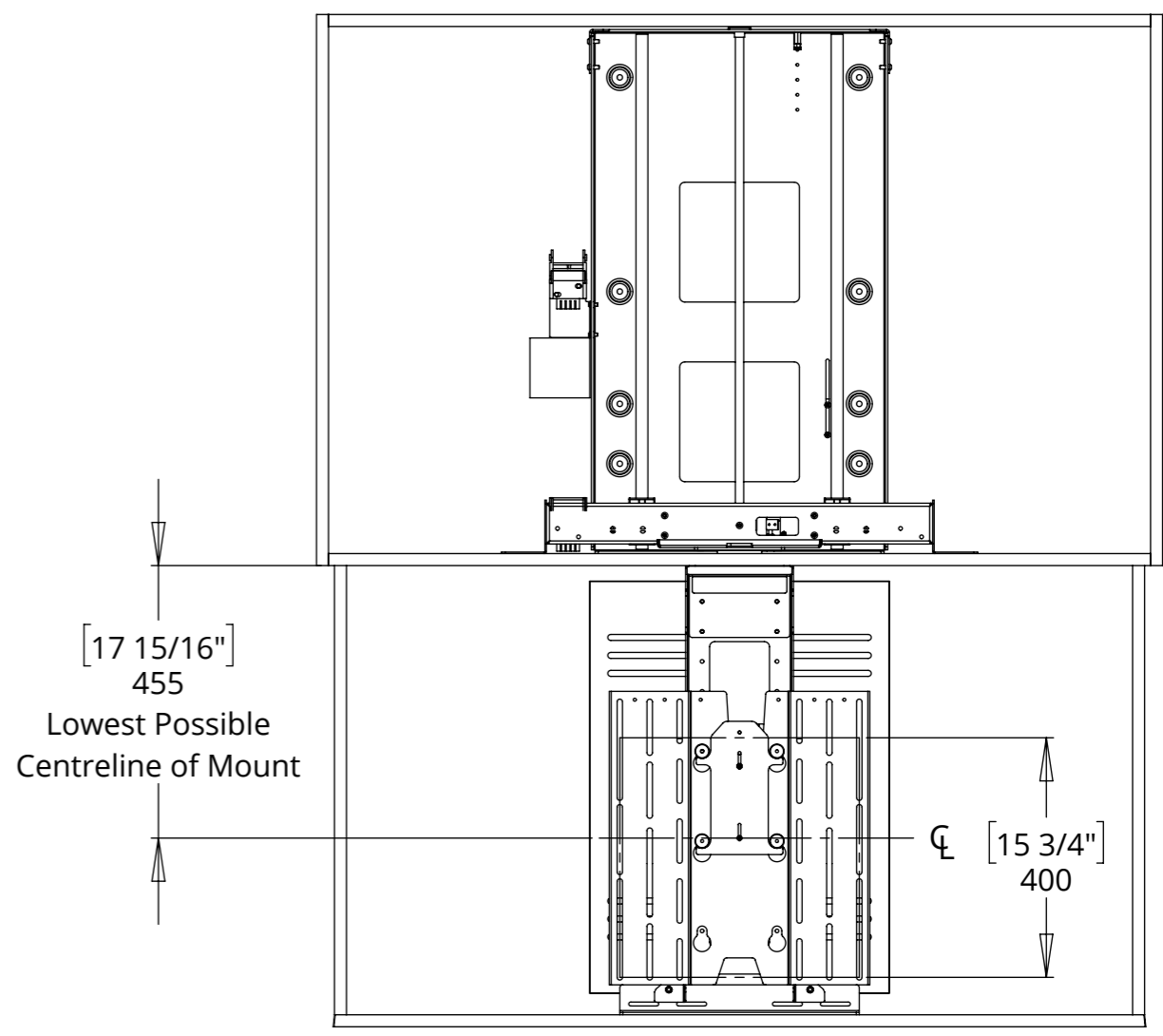
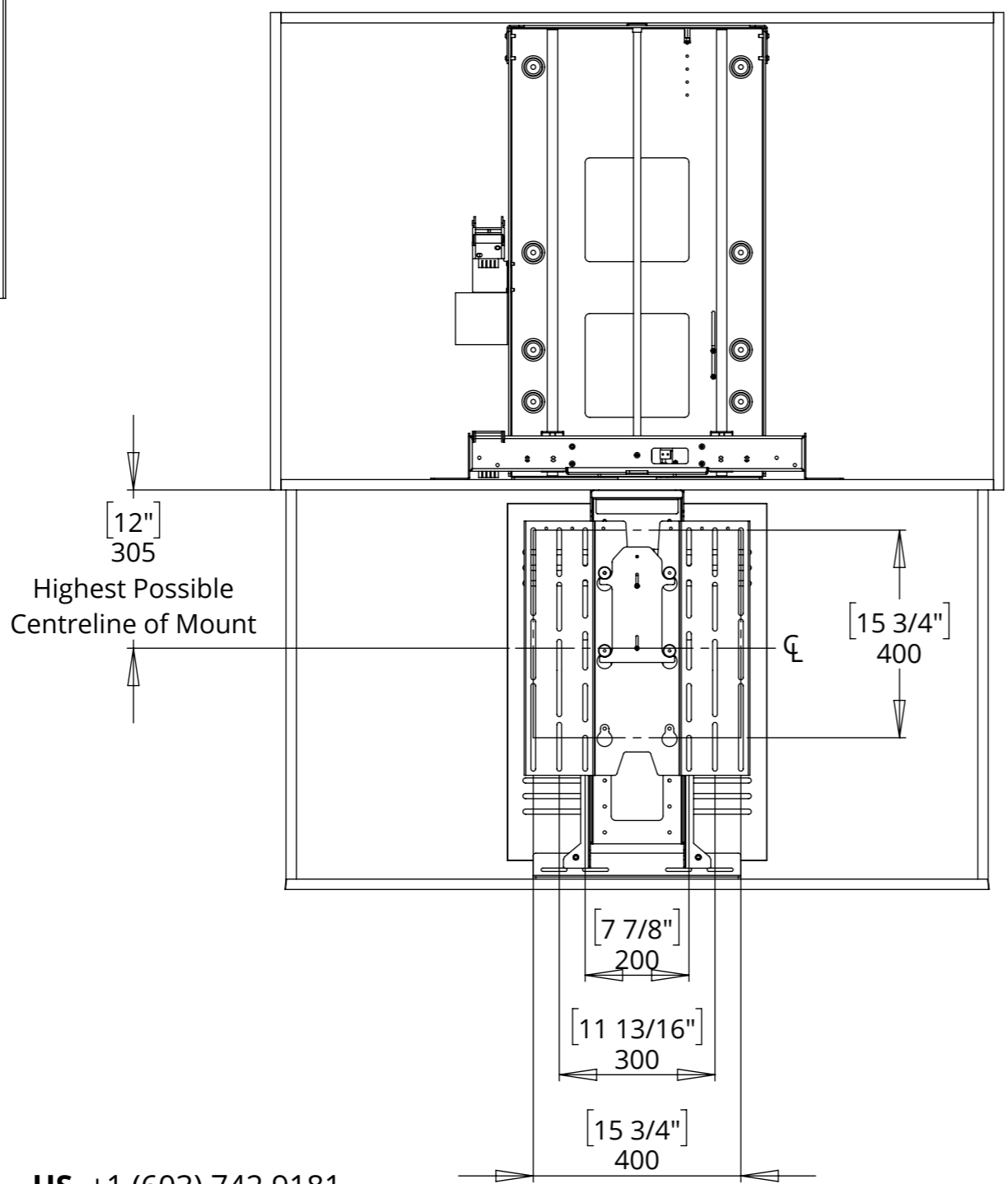
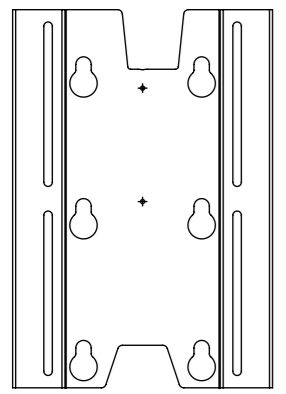
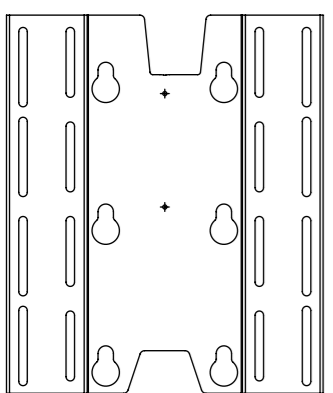
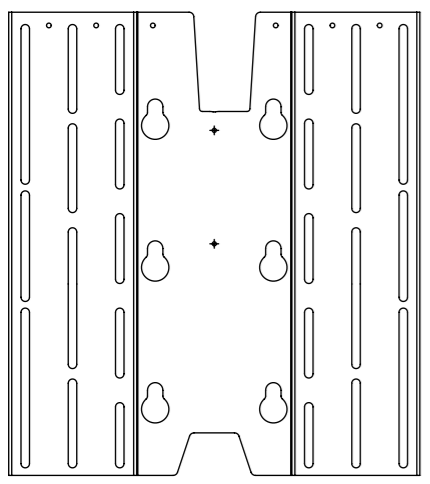

I-LSM-BE 5

INVERTED LIFT SYSTEM FOR BOX ENCLOSURE

MECHANISM INSTALLATION OVERVIEW

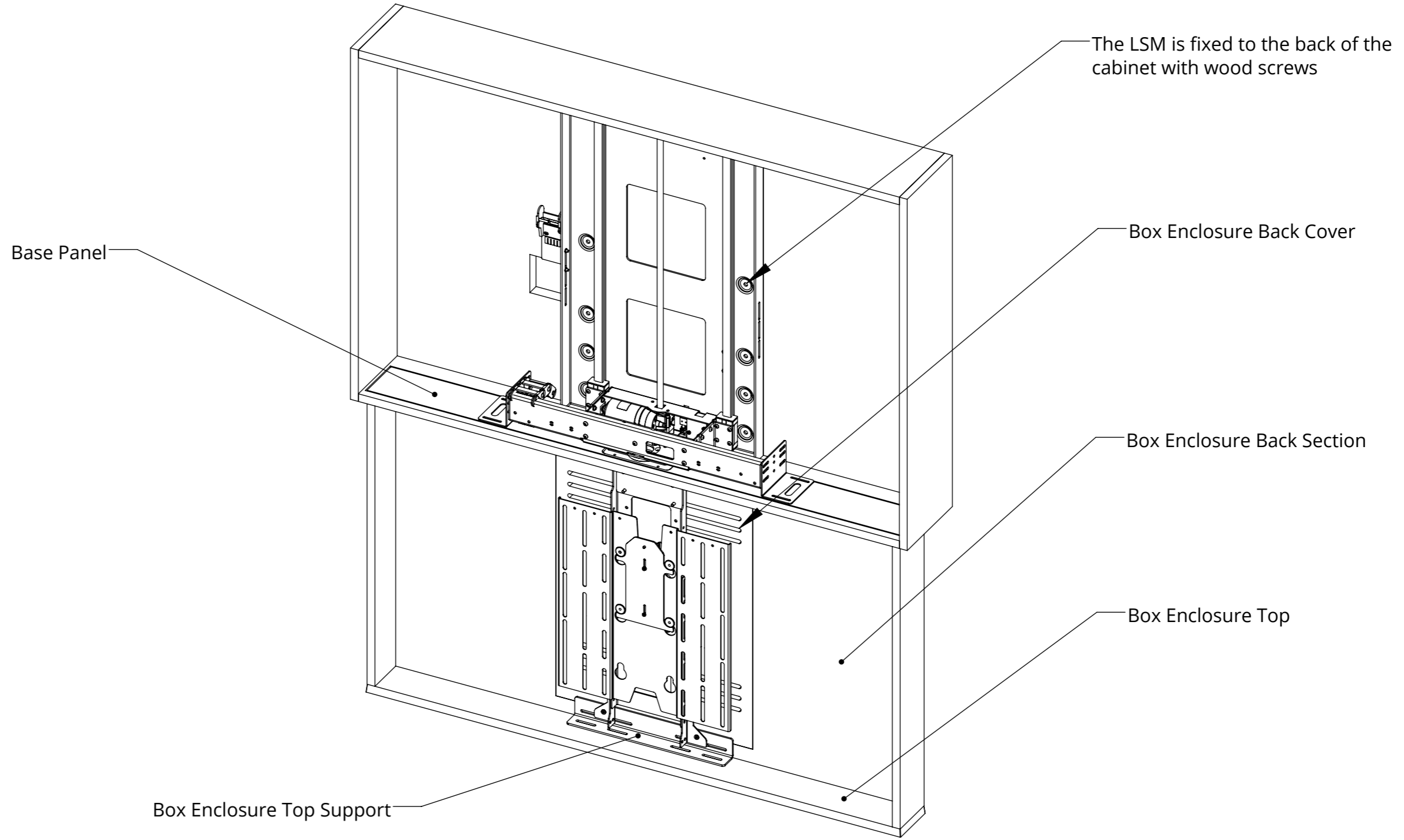

I-LSM-BE 5

INVERTED LIFT SYSTEM FOR BOX ENCLOSURE

OVERALL MECHANISM DIMENSIONS



future automation

MECHANISM - DOWN POSITION

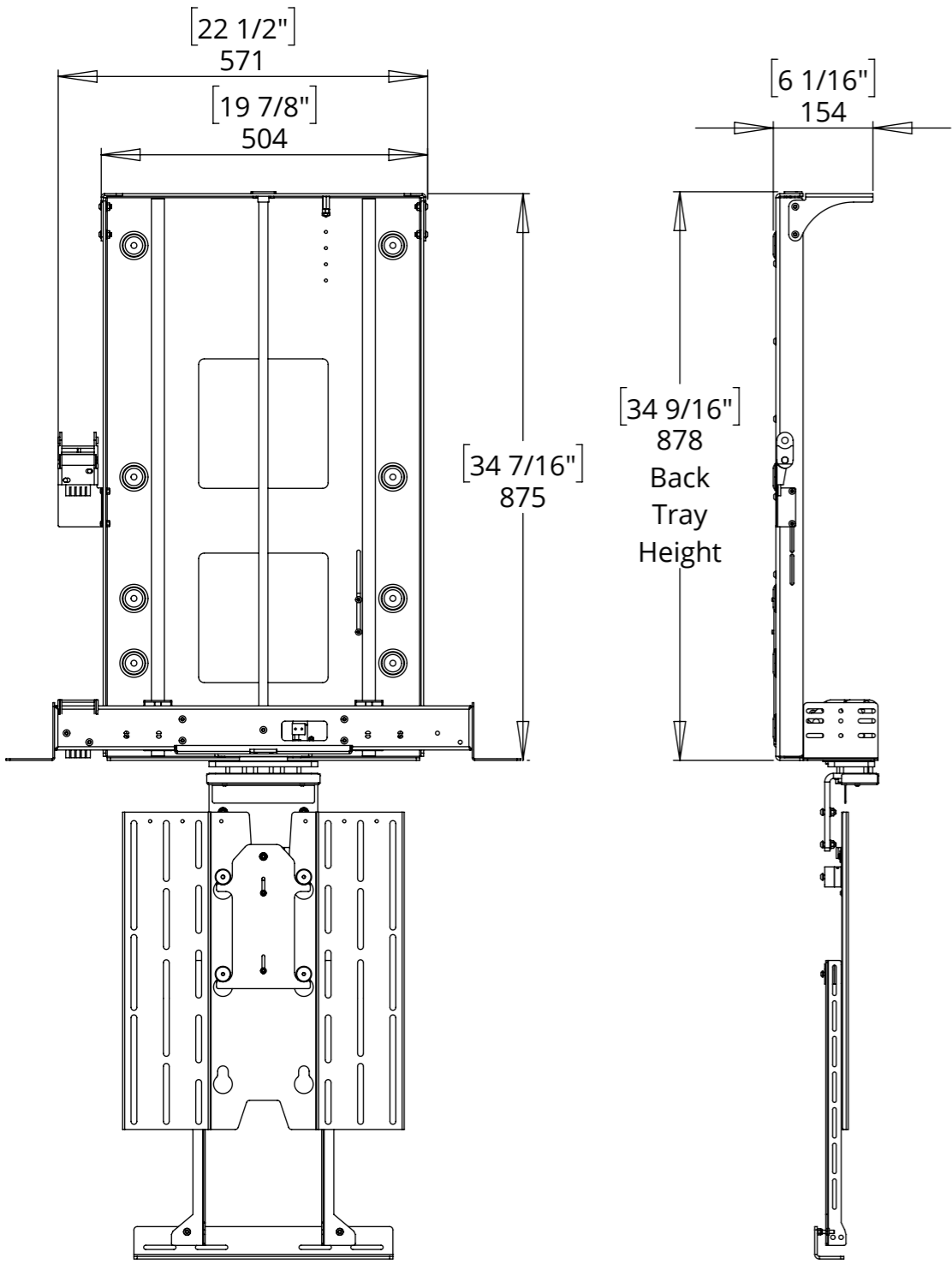

MECHANISM - UP POSITION

