



### For Installations Requiring

- Clear voice announcements
- High-fidelity foreground music
- High-fidelity background music
- Even, omnidirectional coverage

### Description

The Soundsphere Q-8 from SoundTube is more robust than our compact Soundsphere loudspeaker models, offering greater sensitivity and power handling capability. Broad dispersion of all frequencies is achieved with an 8" coaxial driver and proprietary dispersion technologies, providing clear, full-range voice announcements and high-fidelity foreground and background music.

The Soundsphere Q-8 offers a hemispherical coverage pattern and is distinguished by its high sensitivity (93 dB 1 W / 1 M) and high power handling capability (100 W RMS). It can evenly cover a large area with fewer speakers. The Q-8 comes fully assembled and ready to mount using our hanging kit or surface-mounting bracket.

### Features

- Hemispherical coverage pattern.
- Accurate, full-range voice announcements.
- Enhanced high-fidelity music reproduction.
- High sensitivity.
- High power handling capability.
- Hanging or surface-mount.
- Standard white (paintable) and custom colors available.

## SOUNDSPHERE Q-8 PRODUCT SPECIFICATIONS

System Type	8" (203 mm) coaxial
Impedance (Nominal) <sup>1</sup>	8 Ω
Sensitivity dB @ 2.83 V / 1 M	93 dB
Sensitivity dB @ 1 W / 1 M <sup>2</sup>	93 dB
Frequency Response (±3 dB) <sup>3</sup>	200 Hz - 17 kHz
Frequency Response (±10 dB) <sup>3</sup>	80 Hz - 20 kHz
Max. Continuous Peak Power <sup>4</sup>	200 W
Max. Continuous Power RMS <sup>5</sup>	100 W
Max. Power SPL @ 1 M <sup>6</sup>	113 dB
Coverage Angle (±6 dB @ 2 kHz)	135°
Coverage Angle (±6 dB @ 10 kHz)	190°
Coverage Angle (Avg. 500 Hz - 10 kHz)	175°
Transformer	Optional 100 W
Transducer: Low-Frequency Driver	8" (203 mm) polypropylene
Transducer: High-Frequency Driver	0.75" (19 mm) Mylar
Low-Frequency Voice Coil	2"   50.8 mm
Crossover Frequency	1500 Hz
Network Type: High Pass	First order
Enclosure & Reflector Material	Fiberglass with gelcoat finish and rust-resistant hardware
Inputs	Hardwire leads
Colors	White (paintable); custom colors available
Height	19"   483 mm
Diameter	Sphere: 16" (406 mm)   Reflector: 20" (508 mm)
Weight	22.5 lbs   10.2 kg
Shipping Weight	30 lbs   13.6 kg
Packaging	One per box
Optional Accessories	100 W Line Matching Transformer (TX100), Hanging Kit (HK), 24" Hanging Kit Extension (HKEXT), Mounting Bracket (MBM), Universal Beam Clamp with safety strap (BCM), Medium Screen (SM), Medium Screen with Weather Filter (SWFM)
Certifications	CE, RoHS

<sup>1</sup> Impedance listed per IEC 60268-5 with a minimum less than 80% the nominal impedance

<sup>2</sup> 1 W / 1 M sensitivity determined using nominal impedance

<sup>3</sup> Frequency response measured in half or full space as dictated by speaker mounting configuration

<sup>4</sup> Max program power is 3 dB above max continuous power

<sup>5</sup> Continuous power rating, EIA-426-B test

<sup>6</sup> Max output based on max continuous power



## Applications

Providing high-fidelity, full-range music and voice, the Soundsphere Q-8 loudspeaker is ideal for applications such as restaurants, bars/nightclubs, hotel lobbies/atrium, courtrooms, gymnasiums, educational facilities, churches, retail stores, shopping centers, airports, and anywhere clear voice announcements and high-fidelity foreground music are required.

## Patented Technologies

Soundtube constantly develops new technologies which enhance audio product performance. Soundsphere innovations are protected by multiple U.S. and international patents, which explicitly cover SoundTube's enclosure and dispersion technologies. SoundTube actively defends its patents in order to protect SoundTube resellers and end-users.

## Technical Data and Specification Tools

SoundTube strives to provide complete and effective technical information and data to dealers, engineers and designers. All data is available from SoundTube or at [www.soundtube.com](http://www.soundtube.com).

Technical data and downloads include:

- EASE™ data - 3-D polar plots
- EASE™ Address - 2-D modeling for distributed systems
- Tech Sheets - technical information and architectural specs for system engineers
- Distributed System Quick Planning Guide - online configuration tool and step-by-step guide are available to assist in the design of effective public area distributed sound systems using Soundsphere omnidirectional loudspeakers

## Independent Data Acquisition and Verification

All data for Soundsphere loudspeakers from SoundTube is independently collected from and verified by NWAALabs ([www.nwaalabs.com](http://www.nwaalabs.com)) using their proprietary MACH testing system. All data is collected and analyzed according to ASTM, ISO and AES standards using EASERA, TEF and MLSSA. Full balloon data including both phase and magnitude is compiled into a variety of formats including EASE 4.x, GLL and CLF.

## Architectural Specifications

The loudspeaker driver shall consist of one 8" (203 mm) treated pulp fiber woofer with a 0.75" (19 mm) mylar dome tweeter mounted coaxially.

Performance specifications of a typical production unit shall be as follows: Usable frequency response shall extend from 80 Hz - 20 kHz ( $\pm 10$  dB). The vertical polar coverage shall be  $175^\circ \pm 6$  dB. Measured sensitivity (1 W / 1 M) shall be at least 93 dB. The speaker shall have a rated impedance of 8  $\Omega$ . The speaker shall be available for 25, 70, and 100 V modes and shall include 6 power tap selection leads for use with electrical wire nuts or crimp caps. Rated power capacity shall be at least 100 W continuous RMS and conform to EIA-426-B testing. Calculated maximum continuous output at 1 M and shall be 113 dB.

The complete loudspeaker shall be no more than 19" (483 mm) in height. The driver shall be mounted in a spherical enclosure made of fiberglass with

gelcoat finish that is no more than 16" (406 mm) in diameter. The reflector shall be no more than 20" (508 mm) in diameter. The complete loudspeaker shall weigh no more than 22.5 lbs (10.2 kg). All hardware shall be rust and corrosion-resistant stainless or plated steel.

Optional accessories shall include: a 100 W Line Matching Transformer (TX100) with taps for 25, 70, and 100 V constant voltage systems; a Mounting Bracket (MBM) to mount flat against a ceiling surface; a three-element Hanging Kit (HK) for single-point suspension; a 24" Hanging Kit Extension (HKEXT); a Universal Beam Clamp (BCM) with safety strap; a Medium Screen (SM) to protect the speaker from foreign objects; and a Medium Screen with Weather Filter (SWFM) that additionally offers a water protection barrier.

The system shall be the Soundsphere Model Q-8 for high-sensitivity, high-power sound dispersion.

## Warranty

Soundsphere loudspeakers from SoundTube are warranted against failure or malfunction due to defects in materials or workmanship for a period of five years from date of original purchase. Speaker electronics are warranted for three years. Defective units will be repaired or replaced at our option if delivered prepaid to our factory. Repaired or replaced units will be returned at our expense. Warranty does not cover appearance or damage caused by abuse, misuse, neglect, accident, or exceeding maximum rated power. Warranty does not cover labor costs involved in removing and/or reinstalling the defective unit, nor any liability due to accidents caused by improper installation. Warranty is extended to original purchaser and is not transferable.

## SoundTube®

13720 W. 109th St.  
Lenexa, KS 66215  
Phone: 913.663.5600  
Fax: 913.663.3200  
Toll Free: 855.663.5600  
[www.soundtube.com](http://www.soundtube.com)

## Mechanical Drawings

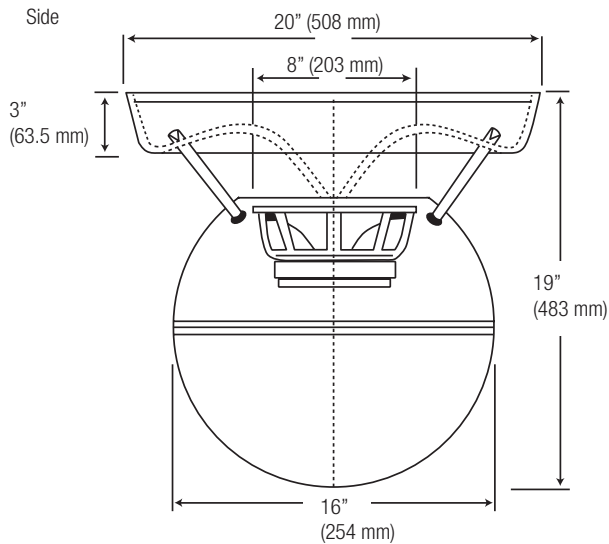

## Accessories

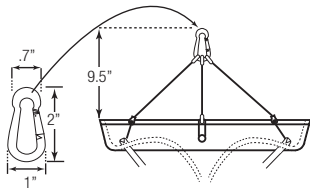

**Hanging Kit (HK)**

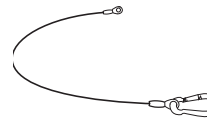

**Hanging Kit Extension (HKEXT)**

24" extension for use with HK.

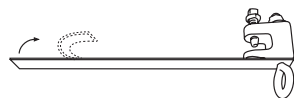

**Universal Beam Clamp (BCM)**

With safety strap

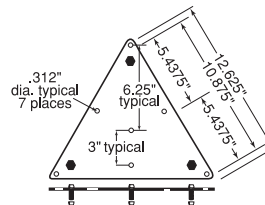

**Mounting Bracket (MBM)**

For mounting speaker on a flat surface.



**Medium Screen (SM)**

Protects speaker driver from foreign objects.

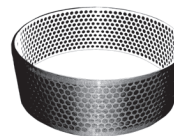

**Medium Screen with Weather Filter (SWFM)**

Protects from foreign objects, plus a water protection barrier.

## Line Matching Transformer (TX100)

The Model TX100 is a 100 W line matching transformer for the Model Q-8 with taps for 25, 70, and 100 V constant voltage systems. The TX100 is designed for factory or field mounting in the Q-8 reflector. Connection to system wiring is via color-coded flying leads. Available taps - 25 V: 25, 12.5 W | 70 & 100 V: 100, 50, 25, 12.5 W.

## Graphs

Hemispherical Frequency Response

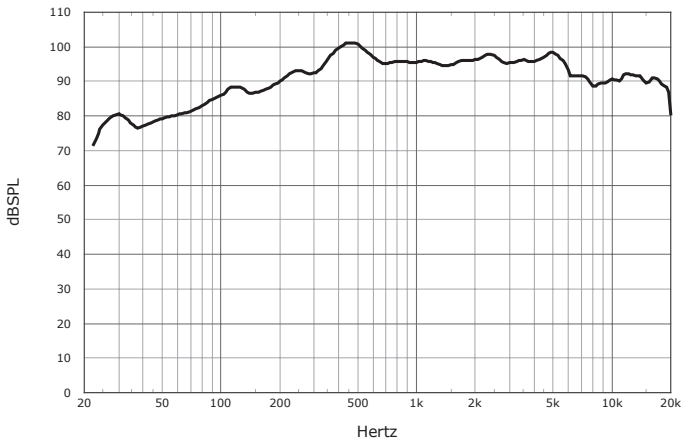

Phase/Impedance Response

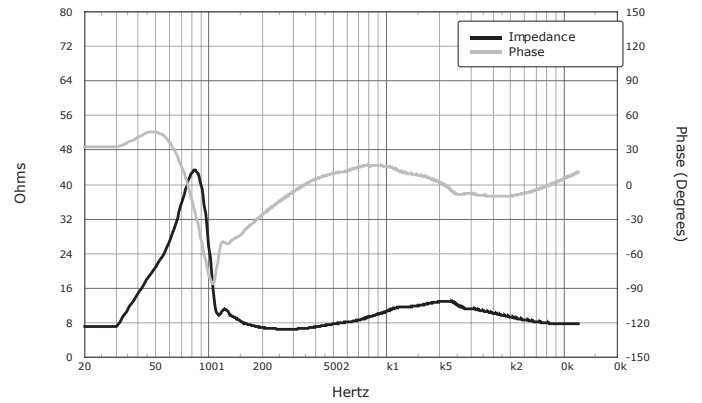

Vertical Beamwidth ( $\pm 6$  dB)

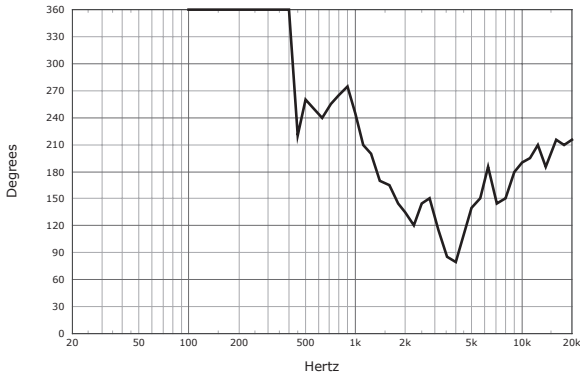

Directivity Index (DI)

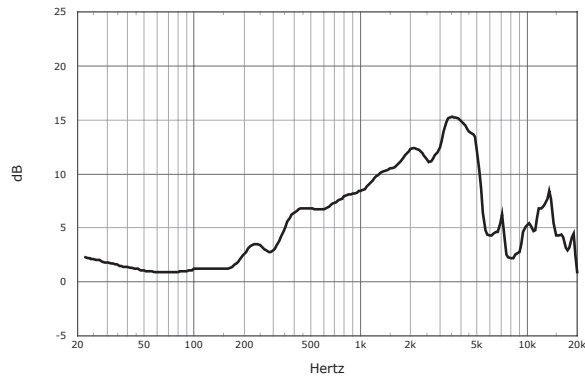

## Plots ( $\pm 6$ dB)

125 Hz

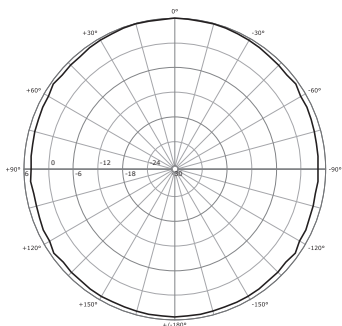

250 Hz

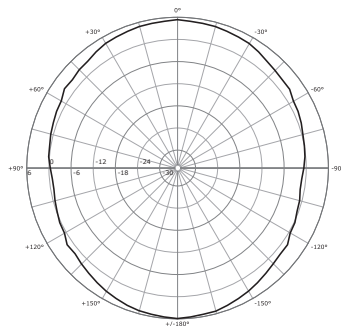

500 Hz

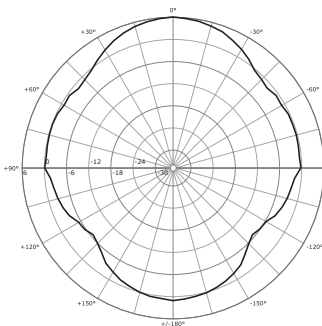

1,000 Hz

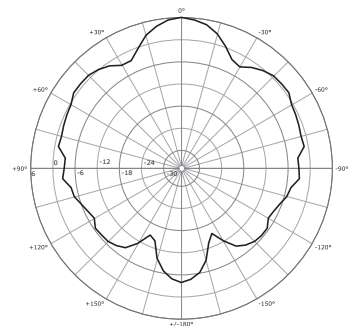

2,000 Hz

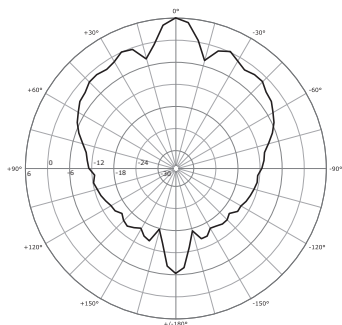

4,000 Hz

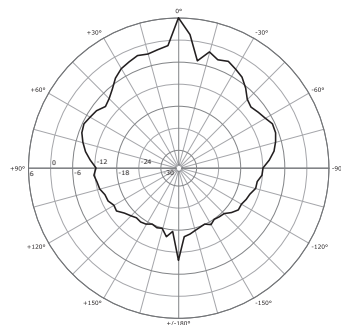

8,000 Hz

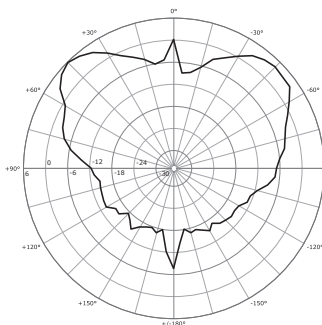

10,000 Hz

