



USER`S MANUAL

**GRATIA**

## SPIS TREŚCI

- 1 **Technical data** — 2
- 2 **Safety tips**
- 3 **Introduction** — 3
- 4 **Installation** — 3
  - Unpacking — 3
  - Package content — 3
- 5 **Interconnections** — 4
  - Interconnection — 4
  - Hook up the signal source — 4
  - Power cord hook up — 4
- 6 **Getting started** — 5
- 7 **TROUBLE-SHOOTING GUIDE** — 5

## 1 TECHNICAL DATA

---

Typ: Phono stage preamplifier

---

Model: Gratia, Line: Evolution

---

AC supply: 5 tablizowany + transformator toroidalny Audio Grade Toroidy.pl

---

Gain MM/MC: 50dB / 60dB

---

Standard EQ: RIAA, Subsonic filter

---

Input impedance MM/MC: 47k  $\Omega$  / 50k  $\Omega$

---

Op-Amp: Burson Audio Supreme V5i

---

Harmonic distortion THD: (20Hz-20kHz): <0.005%

---

Crosstalk: >92dB

---

Signal-noise ratio MM/MC: >92dB / >90dB

---

Power consumption: 12W

---

Net weight 8 kg

---

Dimensions 355x380x95mm

---

## 2 SAFETY TIPS

 **In order to obtain the highest possible sound reproduction quality and for the sake of your own safety, please kindly refer to the following.**

- Never place the preamplifier near heat sources, such as radiators, heaters or direct sunlight. Ensure adequate ventilation and airflow
- We also warn against exposure of the preamplifier to conditions such as very low temperatures and/or high humidity.
- The preamplifier should be plugged directly into a wall socket. If you must use an extension cord, please make sure that it has load parameters sufficient to ensure proper handling of current delivery to the device.
- When cleaning, always disconnect the preamplifier from the power source. Use a dry, soft cloth. Do not use water or cleaning agents.
- If your preamplifier starts to misbehave or to work incorrectly, if it's temperature gets too high or you start feeling smoke - immediately disconnect the device from the mains.
  
- Due to the risk of exposure to high voltages – please do not open the lid of the preamplifier. ATTENTION: This warning remains in force also in a situation where the device is already disconnected from the wall outlet.
- Always replace fuses in accordance with the original, intended specification.
- Do not make repairs on your own, or adjustments beyond those as described in this manual. Execution of any unauthorized repairs or modifications of the device result in a loss of warranty

## 3 INTRODUCTION

New version of Fezz Gratia MM/MC phono stage. In standard Gratia is equipped with anti-vibration feet, adapted to the weight of the device. Backlight logo. A phono stage is designed to work with MM, MC HO and MC cartridges. The amplification section is based on the high end operational amplifier - Burson Supreme Sound Opamp V5i. The heart of the extended power path is the Supreme Audio Toroidy.pl transformer. Undeniable advantage of Gratia is universality. Thanks to the wide settings varieties, it can be a perfect match with a low output signal level MC cartridges.

## 4 INSTALLATION

### UNPACKING

Please kindly check if the packaging of the Gratia phono stage has not been damaged during transit. If you find any damages, please immediately contact your dealer. Remove the preamplifier and accessories from the packaging. Make sure that the content is not damaged.

 **Do not connect the device to the power supply if it has visible signs of damage on it. Please do not dispose the original packaging, so as to facilitate possible shipment of the device in the future.**

### CONTENTS OF THE PACKAGE

Package contains:

- Gratia phono stage
- Power cord
- User's manual
- Warranty card

 **If any of the above items are missing in your package, contact your dealer immediately.**

## 5 INTERCONNECTIONS

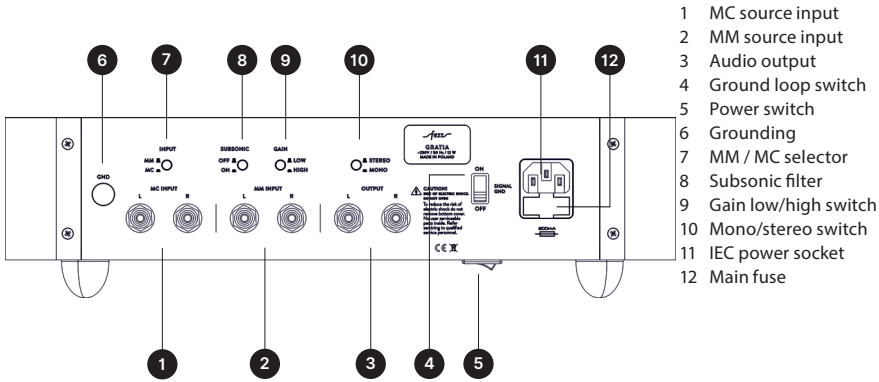

- 1 MC source input
- 2 MM source input
- 3 Audio output
- 4 Ground loop switch
- 5 Power switch
- 6 Grounding
- 7 MM / MC selector
- 8 Subsonic filter
- 9 Gain low/high switch
- 10 Mono/stereo switch
- 11 IEC power socket
- 12 Main fuse

The figures above shows the rear panel view of the Fezz Gratia phono stage.

**⚠ To avoid electrostatic shock to the components of the amplifier, please touch a grounded conductive surface before making any connections. Any and all connections must be made whilst the device is disconnected from the mains power supply. Before making any such connections, make sure that the amplifier is switched off.**

Follow the instructions below to connect your sound system correctly.

### STEP 1 INTERCONNECTIONS

Connect the record player equipped with MM/MC HO cartridge to the MM INPUT of the phono stage. If your record player is equipped with MC cartridge, connect signal wire to the MC INPUT of the phono stage.

Connect the earthing wire to the screw terminal GND in phono stage.

Connect the OUTPUT of the phono stage to a line input (AUX, CD, Tuner, Tape or Video) on your amplifier.

Make sure that the amplifier is switched off. Connect the power cord to the IEC socket on the rear panel of the phono stage.

The phono stage is designed to operate at a rated voltage of 120V / 50-60Hz. Connecting the device to a mains network with incorrect parameters can lead to damage that is not covered by manufacturers warranty.

Press power button on the side of the phono preamplifier.

Gratia phono stage is equipped with:

Subsonic filter - you can use it to reduce or eliminate rumble caused by vinyl imperfections

Mono/Stereo mode switch

Audio ground loop switch

### STEP 2 / POWER CORD CONNECTION

Make sure that the preamplifier is switched off. Connect the power cord to the IEC socket on the rear panel of the preamplifier.

The preamplifier is designed to operate at a rated voltage of 120V / 50-60Hz. Connecting the device to a mains network with incorrect parameters can lead to damage that is not covered by manufacturers warranty.

## 6 GETTING STARTED

Make sure all cables are connected as described above. Select the signal source using the selector located on the front panel of the amplifier. Set the volume knob to minimum. Power on the Gratia preamplifier. Make sure the turntable is turned on and gradually increase the volume with the volume knob at your amplifier.

Please chose optimal settings at the preamplifier which suits to your phono cartridge.

## 7 TROUBLE-SHOOTING GUIDE

If your preamplifier does not work as it is supposed to, it is fairly easy to diagnose and remedy some of the common malfunctions,

THE PROBLEM	PROBABLE REASON	SOLUTION
After turning the power switch to the ON position, the amplifier does not switch on.	A blown fuse	Please exchange to faulty fuse to a new one (0,5 A T), within the fuse holder as depicted with index 12 on page 4 of this user's manual.
	An improper connection of the mains cable	Please check if the plugs of the mains cable are properly inserted into the electrical mains socket and to the socket as depicted with index 11 on page 4 of this user's manual.

If you have verified the aforementioned situations, and your problem still persists, please contact your local Fezz Audio dealer.

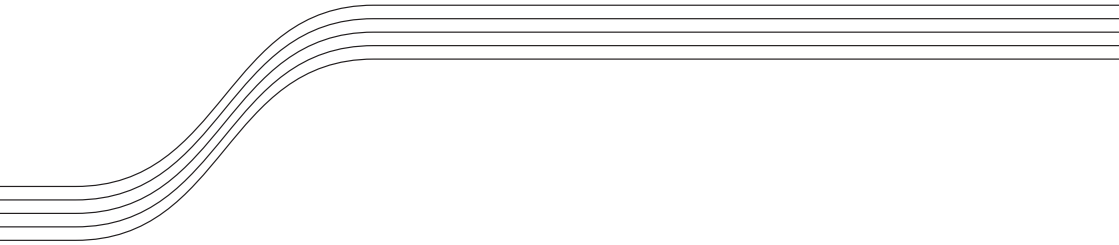

[WWW.FEZZAUDIO.COM](http://WWW.FEZZAUDIO.COM)